

**GENERAL INSTRUCTIONS FOR ASSEMBLY AND SETTING-UP OF
TOMSED MODEL THT-100C, EC or ECP - FULL SECURITY 7 FOOT HIGH TURNSTILE**

1. **Assembly of Rotor:**

Attach lower flange with round pin to the rotor section (arm is 1-3/4" from the bottom). Attach upper flange with square bushing to the other side of rotor and fasten with stainless steel hex head bolts 3/8" x 3" long and lock washers and nuts.

2. **Assembly of Shield:** (For galvanized steel shield is pre-assembled)

3. **High Turnstile Assembly (Overview):**

Set ceiling plate and channel down into proper position. Align middle shield assembly mounting holes on ceiling plate with holes in top channel. Ensure center support hole in channel and ceiling plate are also aligned. Transfer all holes along ceiling plate and both ends of channel onto the floor, as well as marking the center of the channel along length and width for bottom base plate location. Remove channel and ceiling plate and place base plate so that center of hole is at center of channel as previously marked. Transfer 3 holes from base plate to floor. Drill and set anchors (9) accordingly.

Fasten shield and barrier assemblies onto floor. Mount bottom plate onto floor. Place rotor assembly onto base plate.

Mount channel over rotor, barrier and shield assembly. Insert ceiling plate between shield assembly and channel. Fasten barrier post and middle of shield assembly to channel with 4 hex head screws 3/8" x 1" long. Fasten right and left side of shield assembly to ceiling plate with hex head screws 3/8" x 1" long. Fasten center of ceiling plate to channel using 1 hex head screw 3/8" x 3/4". Plumb, and tighten all fasteners. Brace at top to adjacent surface as required.

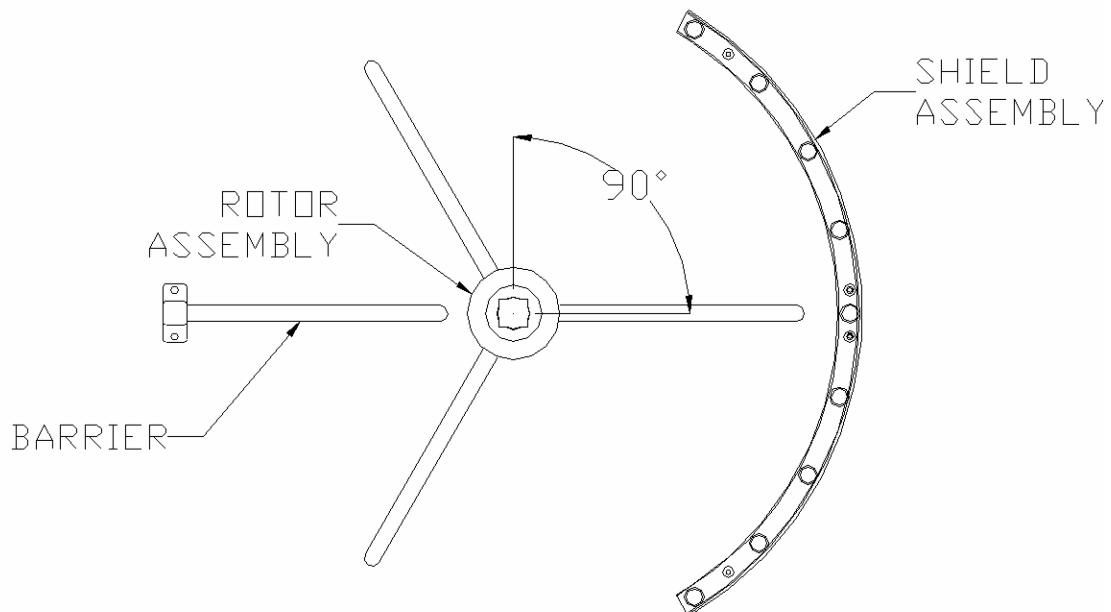

INSTALLATION
(Floor area location and preparation)

1. Ensure area is of adequate size and that it is designed (4 to 5 inches concrete) to accommodate turnstile; that the site is flat and level within $\frac{1}{4}$ " to permit trouble free operation.
2. Mark a center line in the required location for reference in the layout of the anchor stud holes.  figure 1.

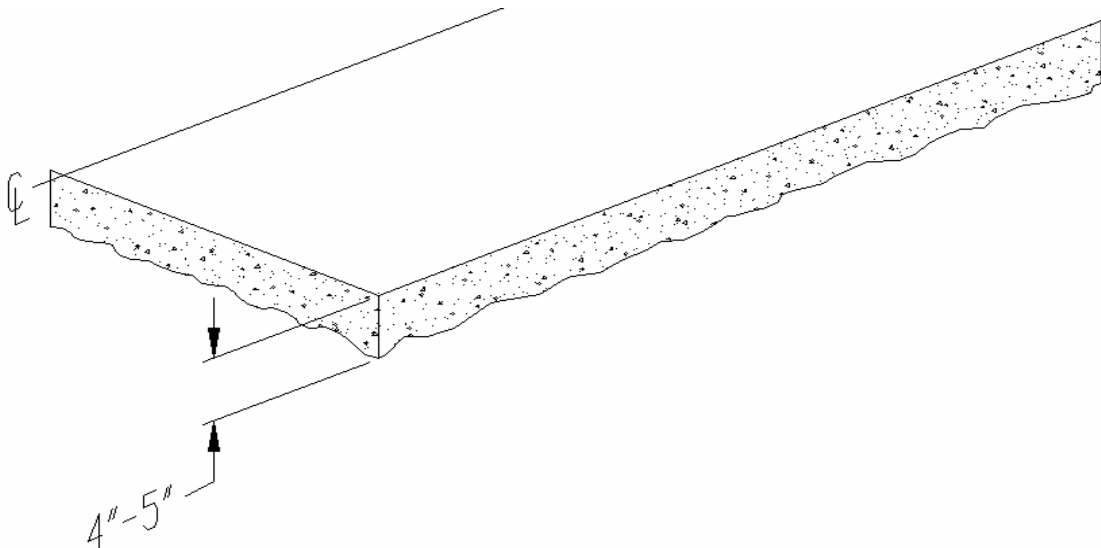

Figure 1

3. Attach ceiling plate to the channel with one screw, hex head $\frac{3}{8}$ " - 16 X 1"; washer, lock $\frac{3}{8}$ "; nut, hex head $\frac{3}{8}$ " - 16. See Figure 2.

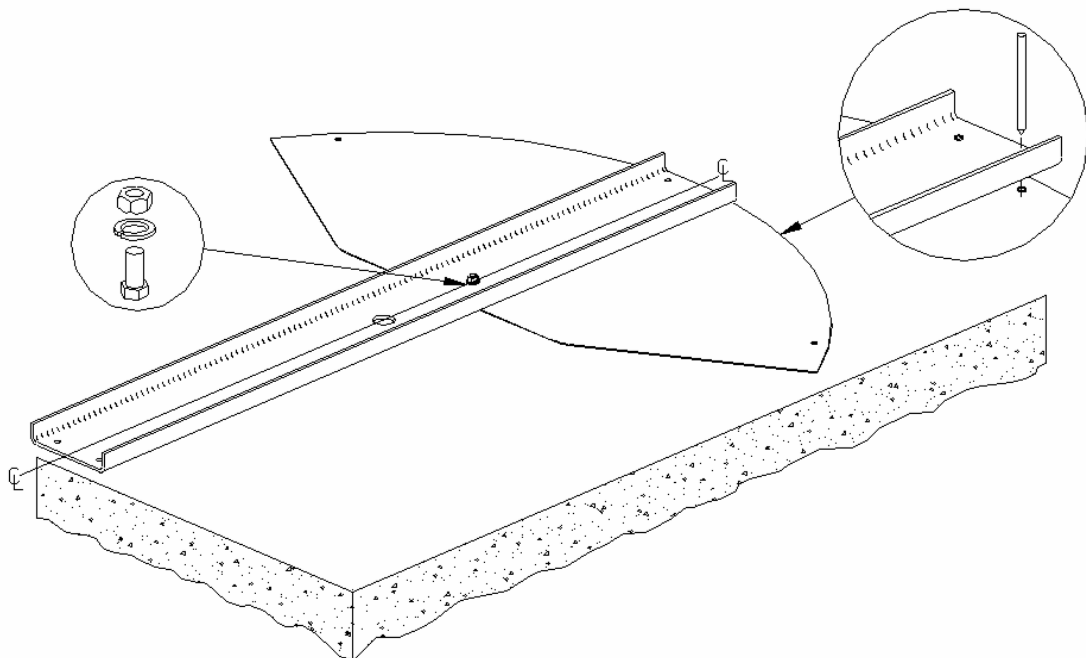

Figure 2

- 4. Next place this assembly (ceiling plate and channel) on the floor to mark anchor stud holes. Align the two 1/2" holes located at the shield post end of the ceiling plate with the proper two holes in the channel. Keep holes aligned and move assembly to position on the previously marked center line (to assure good alignment tighten the 3/8" nut and screw while keeping a 1/2" center punch in one of the two holes of both the ceiling plate and channel at the shield post end). See Figure 2. Center of channel falls on center line reference established in #2 above.

- 5. Making sure the assembly is held in place, mark location for six anchor stud holes using 1/2" center punch, two holes at barrier post end, two holes for center shield post end, two holes at left shield post and two holes at right shield post. See Figure 3.

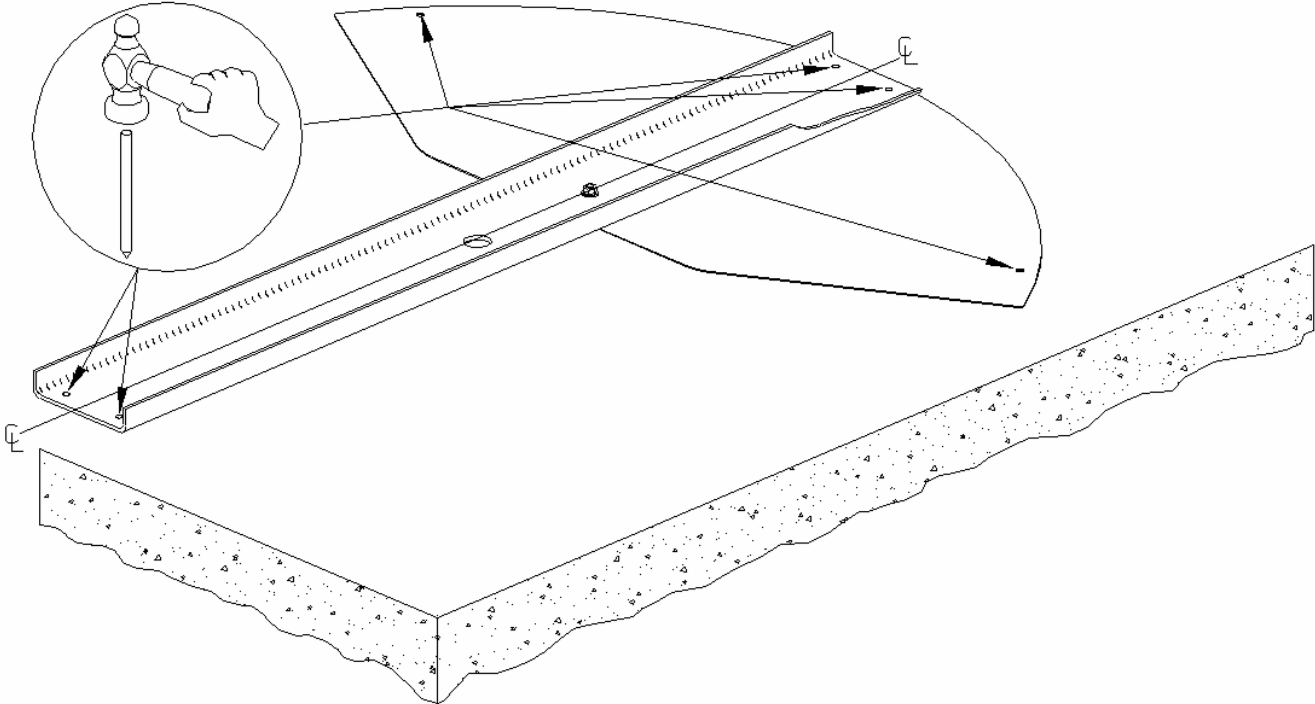

Figure 3

6. Mark lower flange center point to coincide with center of bottom plate. Using punch mark the point on the center line 29" from the center of the barrier post mounting holes. See Figure 4.

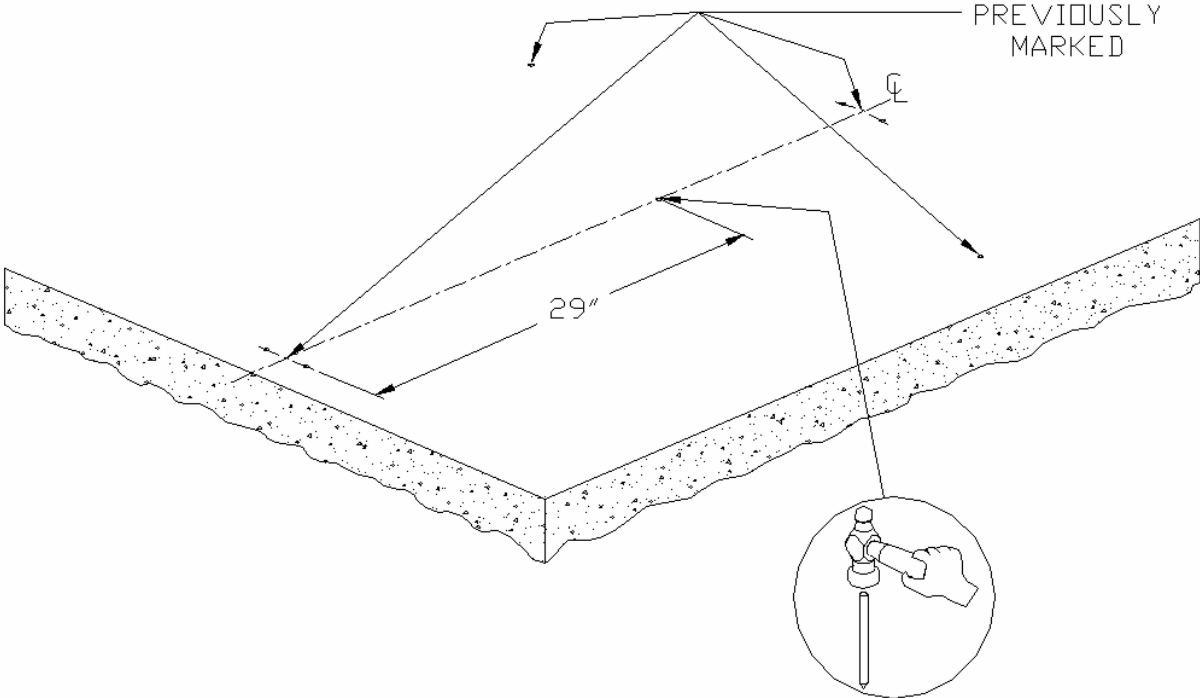

Figure 4

7. Locate the position for the bottom plate by centering the hole with the mark made in #6 above. Rotate the bottom plate so that one of the three mounting holes also aligns with the center line reference on the barrier post side. Firmly holding the bottom plate mark three 1/2" holes with the 1/2" center punch to the floor. See Figure 5.

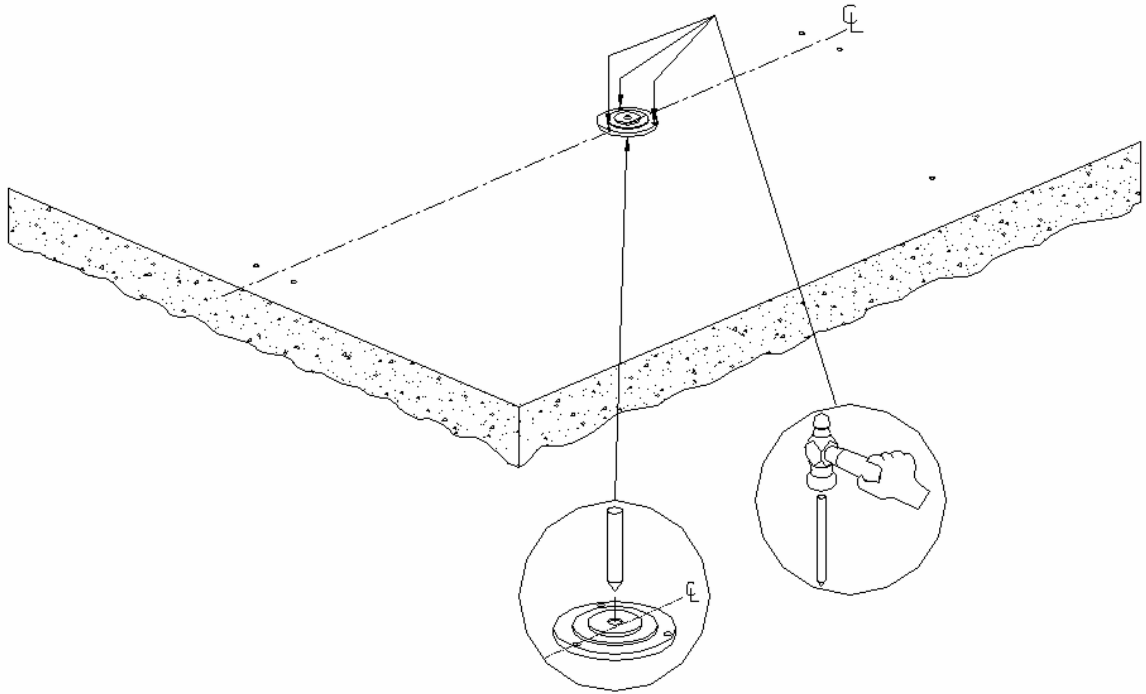

Figure 5

8. Remove bottom plate, tools and any other material and drill (9) 3/8" holes, 4 inches deep for anchor studs, two holes for barrier post, three holes for bottom plate and four holes for shield assembly. See Figure 6. Clean holes.

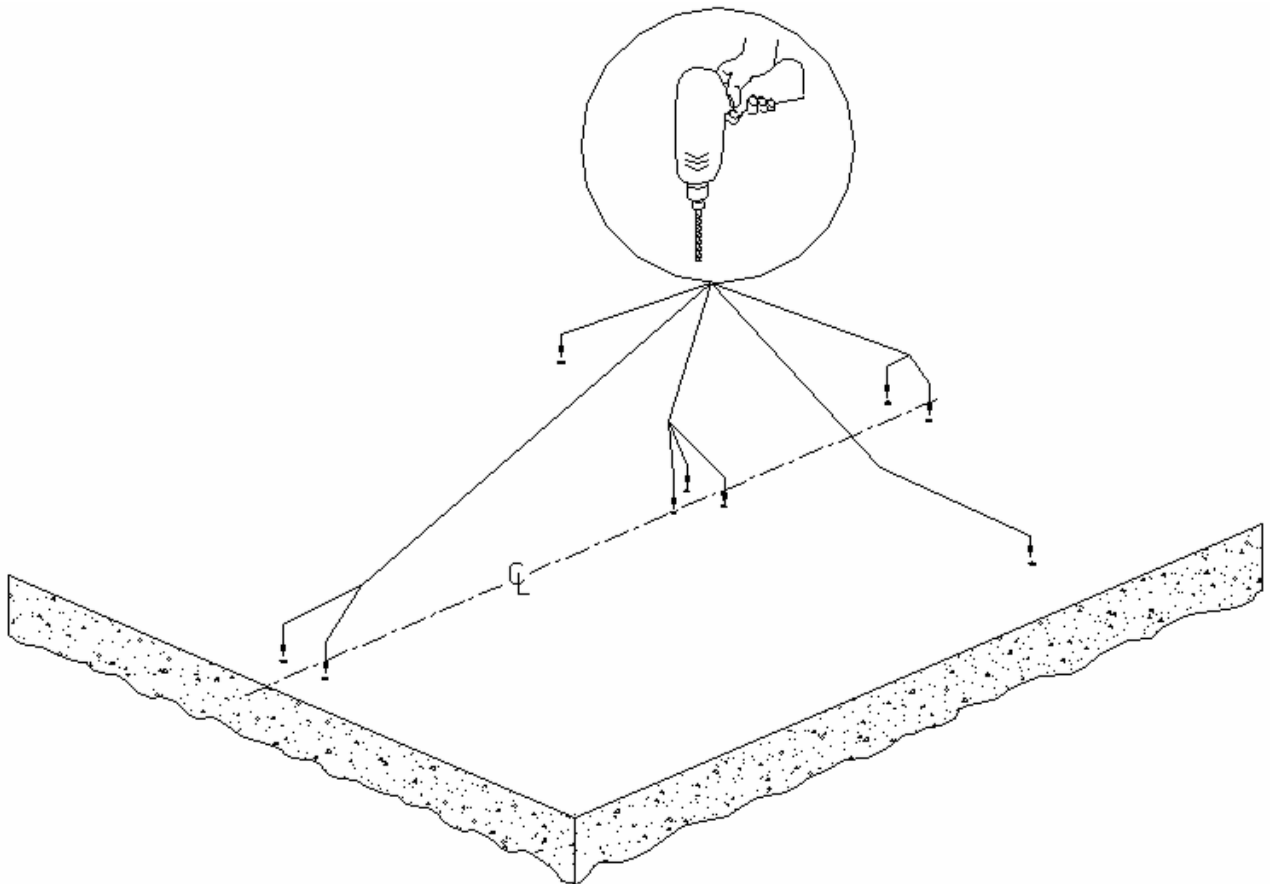

Figure 6

ASSEMBLY AND SET-UP

1. Locate anchor stud holes for bottom plate and drive in stud bolts 3/8" – 16 X 4" min. See Figure 7. One inch of anchor stud should remain above floor surface (this allows for thickness of mount plus 1/2 inch of make-up for washer and nut). See Figure 8. Place the bottom plate over studs and secure with lock washers, and nuts. See Figure 9.

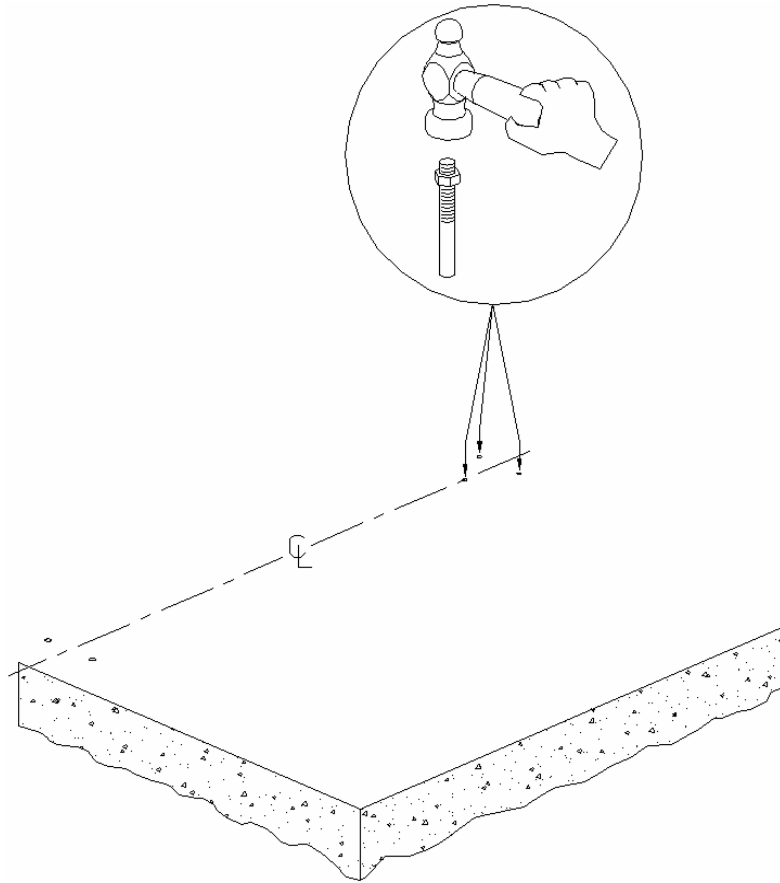

Figure 7

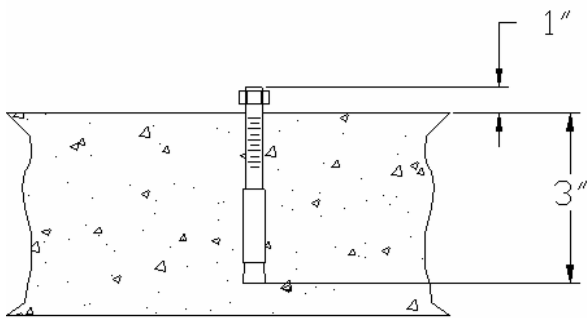

Figure 8

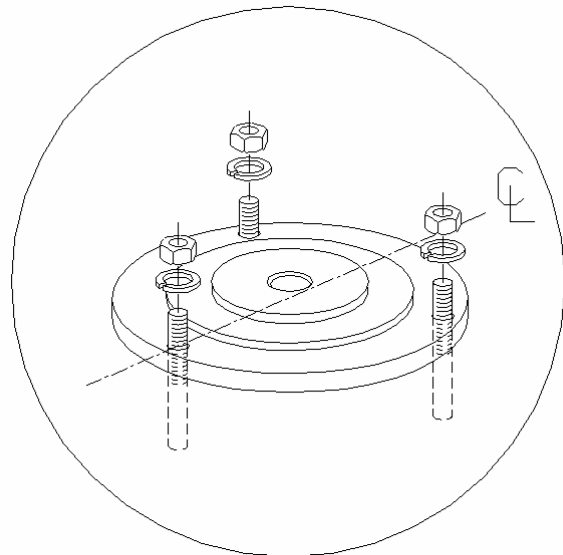
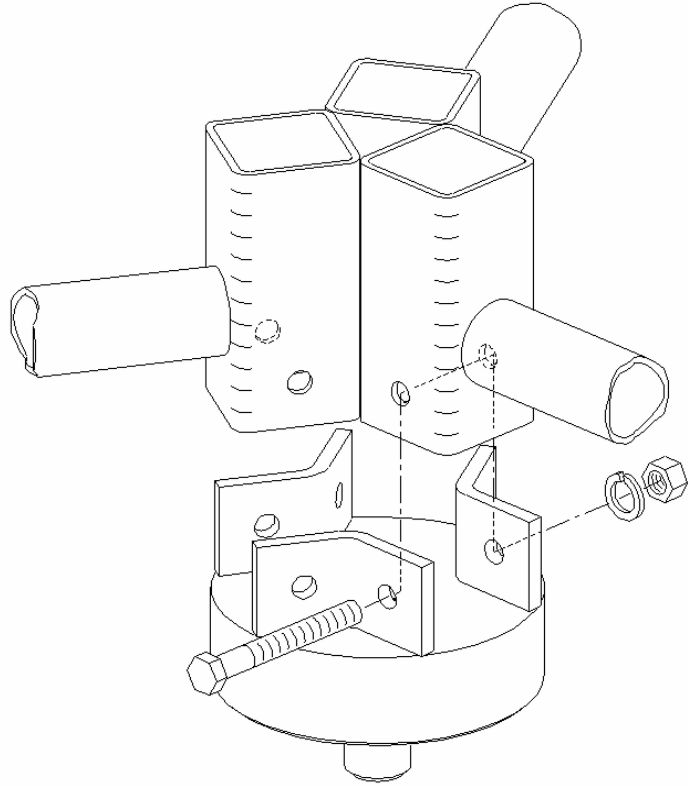

Figure 9

2. Attach lower flange to rotor assembly using three screws 3/8" - 16 X 3", three lock washers, and



three nuts. See Figure 10.

Figure 10

3. Attach upper flange to other end of rotor assembly using the same type hardware; three screws; 3/8" -16 X 3", three lock washers, and three nuts. See Figure 11.

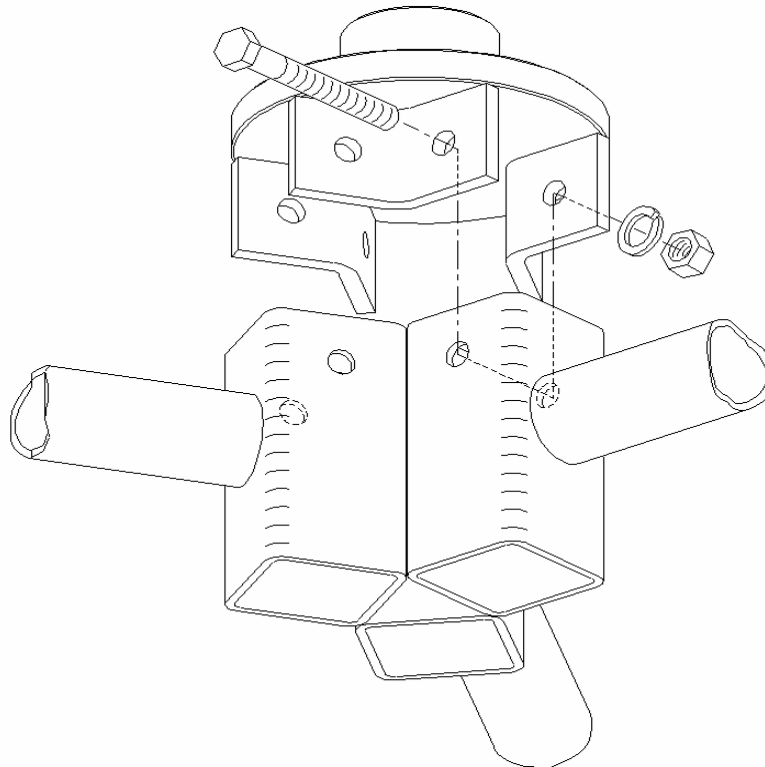

Figure 11

4. Place thrust bearing on bottom plate which has been positioned on the floor. See Figure 12.

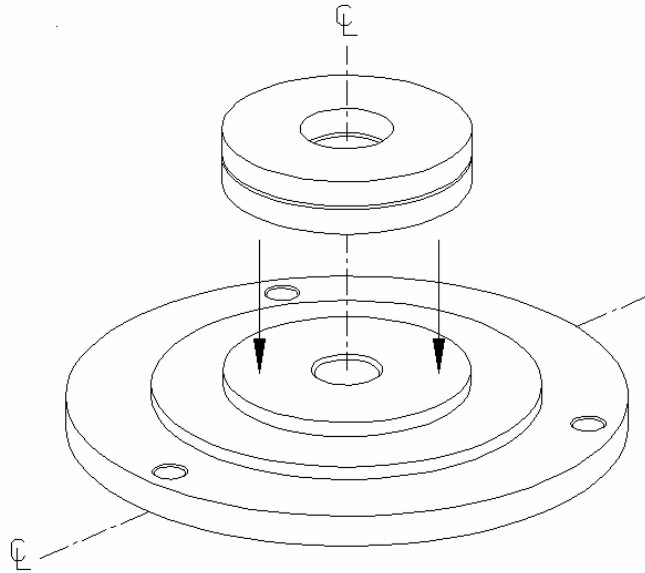

Figure 12

5. Locate the anchor holes for shield assembly. Drive anchor studs into these holes; four studs required; See Figure 13. Allow $\frac{1}{2}$ " inch of anchor stud to remain above floor surface (allows $\frac{1}{8}$ " inch for wall thickness of channel plus $\frac{3}{8}$ " make-up for washer and nut).

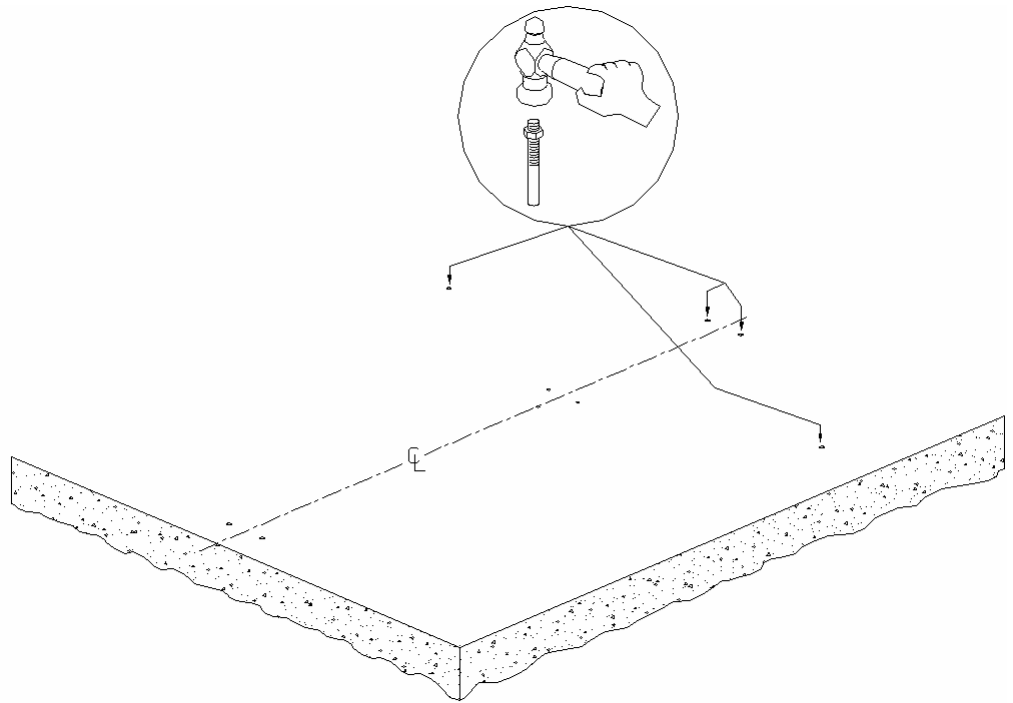

Figure 13

6. Install shield assembly on anchor studs and secure with washer and nut. See Figure 14.
Do not fully tighten nuts at this time.

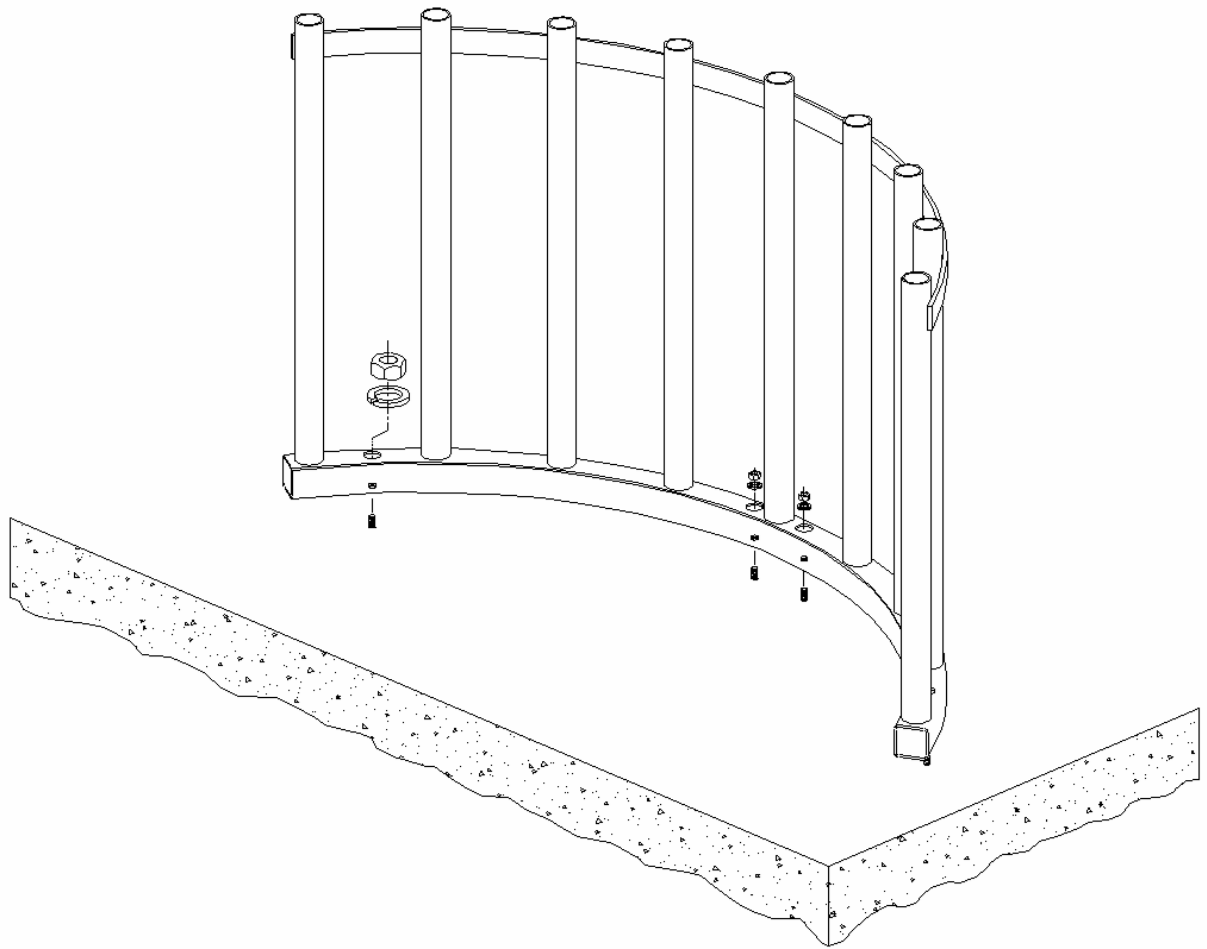

Figure 14

7. Locate holes (2) and drive in anchor studs for barrier post. See Figure 15. Allow one inch of

anchor stud to remain above floor surface. Secure completed post with washers and nuts. Bottom arm of barrier post should measure six inches from floor. See Figure 16. Do not fully tighten nuts at this time.

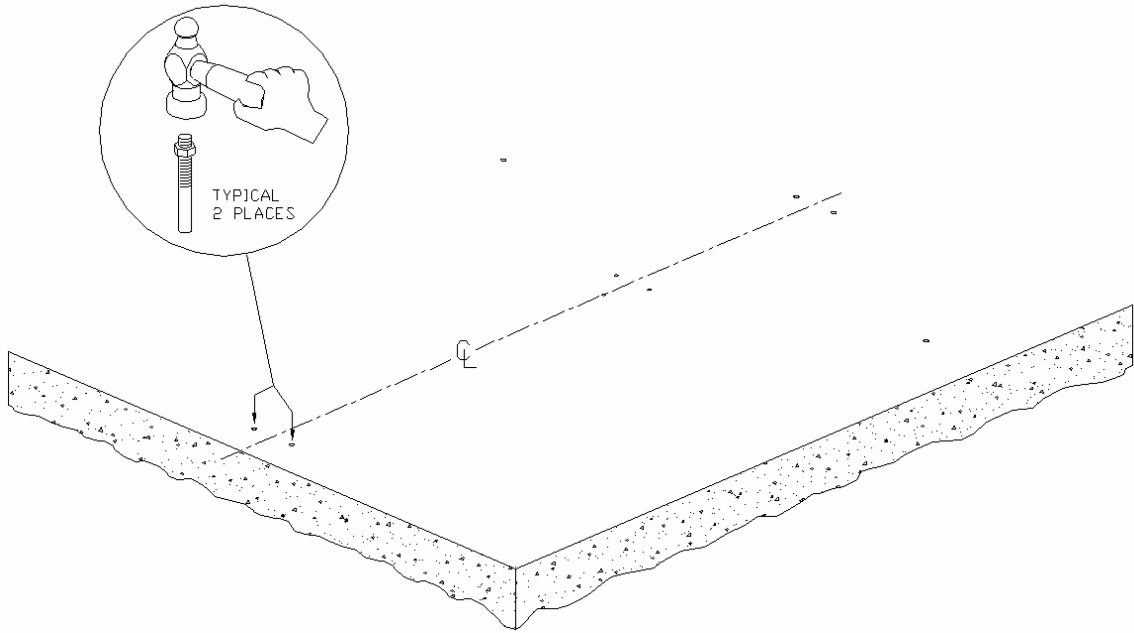

Figure 15

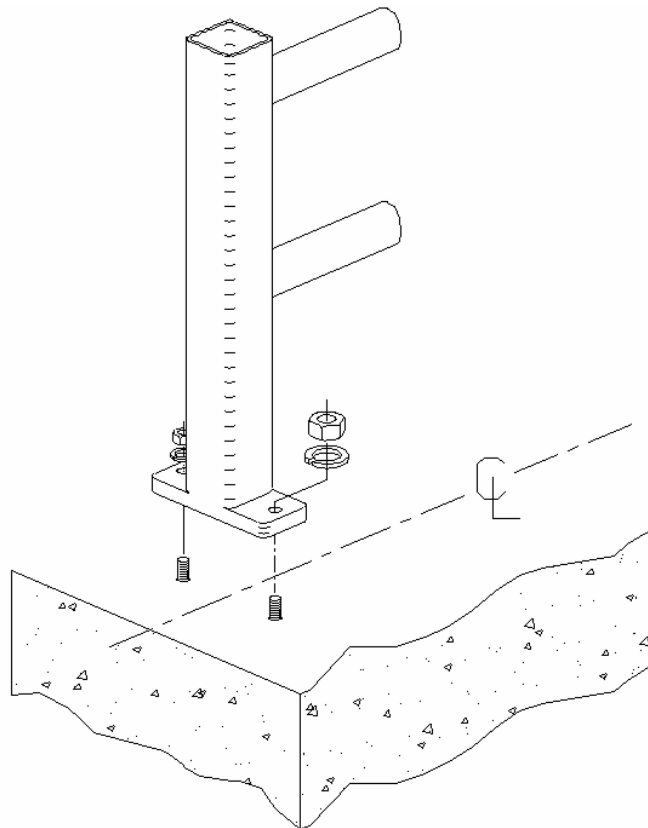

Figure 16

- 8. Remove cover from channel and place channel on top of barrier post, upper flange and shield assembly. Align mechanism shaft (extends from channel) and work down easily into the upper flange. See Figure 17. When seated, channel will rest on barrier post, rotor assembly, and shield assembly. Insert the two screws 3/8" – 16 X 1" through the channel to shield assembly; do not secure.

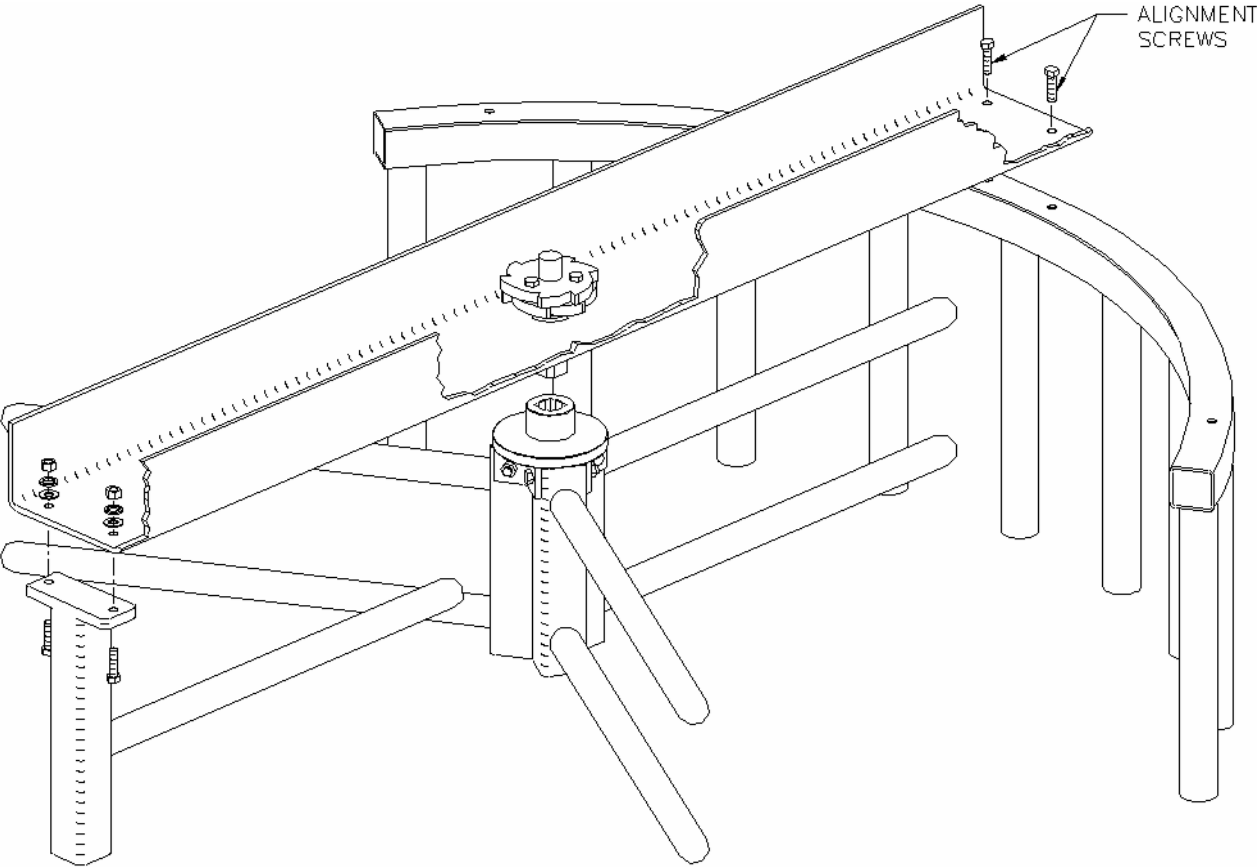

Figure 17

- 9. Fasten barrier post assembly to channel with two screws 3/8" – 16 X 1", two flat washers, two lock washers, and two nuts.

10. Insert ceiling plate between shield assembly and channel and secure with one screw $3/8'' - 16 \times 1''$, one flat washer, one lock washer, and one nut. Take out the two screws not secured in the channel and shield assembly. Re-insert these screws going through the shield assembly, ceiling plate and channel and secure with flat washers, lock washers, and nuts. Insert screws for left and right side of shield assembly and secure with flat washers, lock washers, and nuts. Do not tighten at this time.

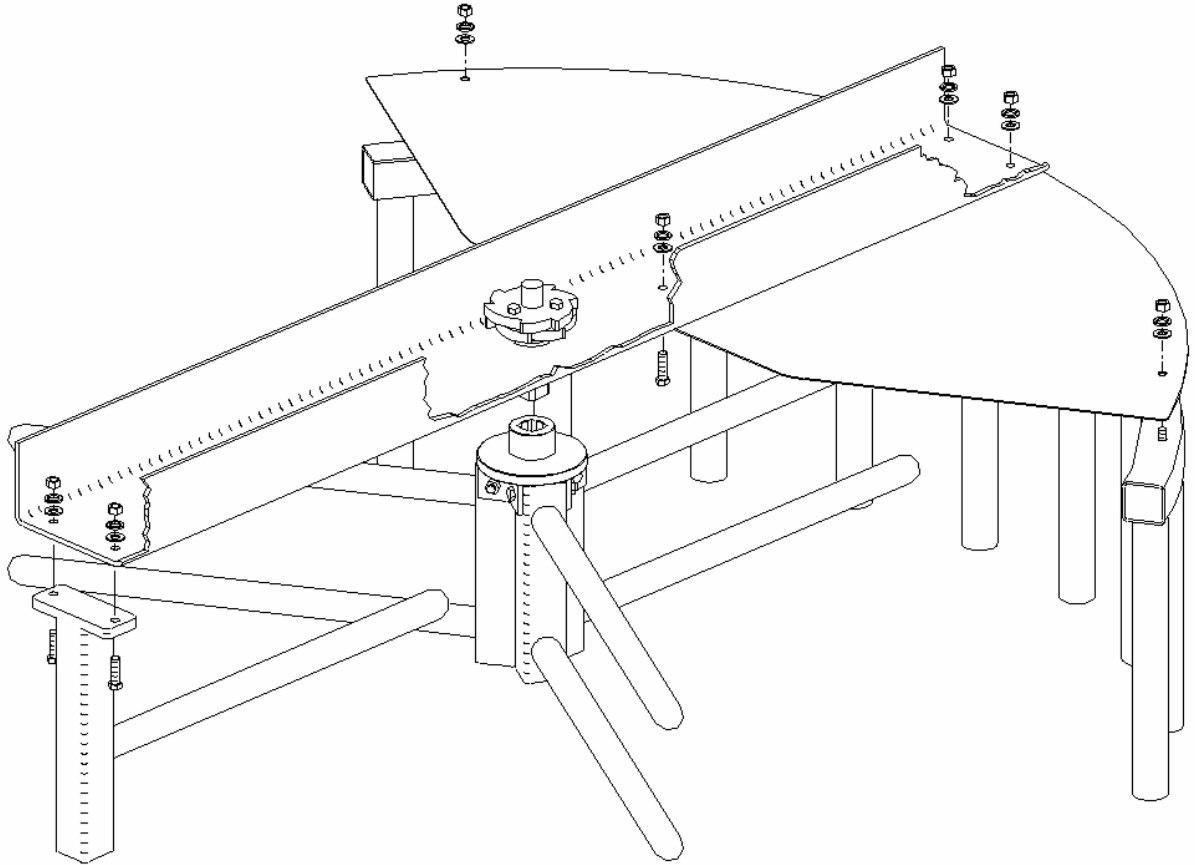

Figure 18

13. Plumb turnstiles and tighten all screws and nuts. First tighten floor fasteners then tighten all channel fasteners.