

# **Sentex Systems**

---

## **INSTALLATION AND MAINTENANCE MANUAL**

**MODEL: SL580  
Heavy Duty Slide Gate Operator**

**MODEL: SL590  
Heavy Duty, Harsh Environment  
Slide Gate Operator**

**– READ AND FOLLOW ALL INSTRUCTIONS –**

**01-G0547  
G416**

## SUPPLIED PARTS

Inspect the operator for any possible shipping damage and any shortage of parts. Please note that if accessories were ordered with this unit, some may be packed separately.

### FOR ALL MODELS: SL580 and SL590

PART NO.	DESCRIPTION	QTY.
1 -1 -1 -1	Powerhead unit	1
307-PBX-GSL	PARTS BOX, Includes:	1
02-4015	Stop Button	1
10-3209	Gate Bracket	2
19-3025	Drive Chain	varies
305-PB-GSL	HARDWARE KIT, Includes:	1
11-3503	Take-Up Bolt	2
14-0609	Take-Up Spacer	2
80-3001	2" U-Bolt, 5/16"-18	4
80-3002	3" U-Bolt, 3/8"-16	4
82-QN43-12	Set Screw, 7/16"-14	4
84-WH-31	Hex Nut, 5/16"-18	8
84-WH-38	Hex Nut, 3/8"-16	12
84-WH-50	Hex Nut, 1/2"-13	4
85FW-38	Flat Washer, 3/8"	12

## MODEL CLASSIFICATIONS

### Residential Vehicular Gate Operator – Class 1

A vehicular gate operator or system that is intended for use in a home of one to four single family dwelling or a garage or parking area.

### Commercial/General Access Vehicular Gate Operator – Class 2

A vehicular gate operator or system intended for use in a commercial location or building such as a multi-family housing unit of five or more single family units, hotel, garages, retail store, or other building servicing the general public.

### Industrial/Limited Access Vehicular Gate Operator – Class 3

A vehicular gate operator or system intended for use in an industrial location or building such as a factory or loading dock area or other locations not intended to service the general public.

### Restricted Access Vehicular Gate Operator – Class 4

A vehicular gate operator or system intended for use in a guarded industrial location or building such as an airport security area or other restricted access location not servicing the general public, in which unauthorized access is prevented via supervision by security personnel.

MODEL	CLASS 1	CLASS 2	CLASS 3	CLASS 4
SL580	3	3	3	3
SL590	3	3	3	3

### TYPES OF SLIDE GATES

These gate operators are intended to be used with slide gates of the following type: Track mounted, overhead, cantilever, and track guided v-track.

## SPECIFICATIONS

MODEL	H.P.	GATE SPEED	MAX. GATE WT.	MAX. CANT'L. WIDTH	MAX. O/H WIDTH	MAX. V-TRACK WIDTH
SL580	1/2	11"/sec.	1000 lbs.	25 ft.	45 ft.	35 ft.
SL580	3/4	11"/sec.	1300 lbs.	30 ft.	60 ft.	45 ft.
SL580	1	11"/sec.	1600 lbs.	35 ft.	70 ft.	50 ft.
SL580	1-1/2	11"/sec.	1900 lbs.	40 ft.	80 ft.	60 ft.
SL590	1/2	12"/sec.	1100 lbs.	25 ft.	45 ft.	35 ft.
SL590	3/4	12"/sec.	1400 lbs.	30 ft.	60 ft.	45 ft.
SL590	1	12"/sec.	1700 lbs.	35 ft.	70 ft.	50 ft.
SL590	1-1/2	12"/sec.	2100 lbs.	40 ft.	80 ft.	60 ft.
SL590	2	12"/sec.	2500 lbs.	45 ft.	90 ft.	70 ft.

### IMPORTANT:

Please leave this manual at the job site, preferably with the end user or facility manager.

# CYCLE RATES

MODEL	APPLICATIONS	*CYCLE RATE PER HOUR
SL580	Heavy Duty, Industrial	20
SL590	Heavy Duty, Industrial with Harsh Environment	25

\*Cycle = One full open and one full close.

# OPERATOR DIMENSIONS

## MODEL SL580

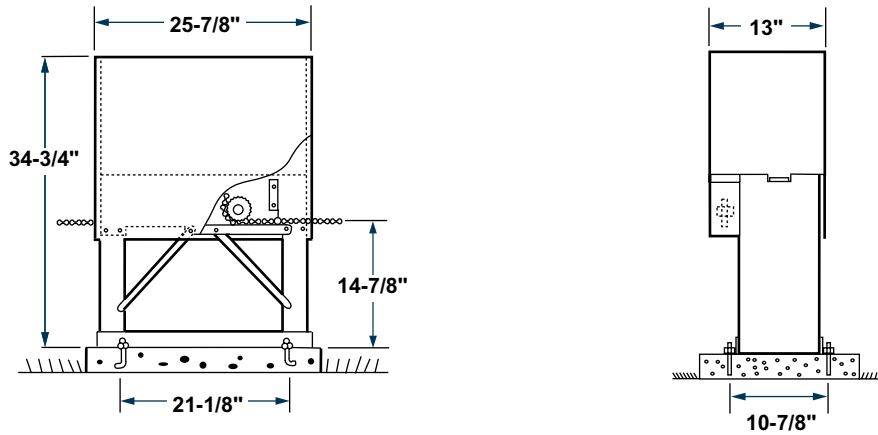

NOTE: Diagonal support braces shown, are standard only on 1-1/2Hp. operators.

## MODEL SL590

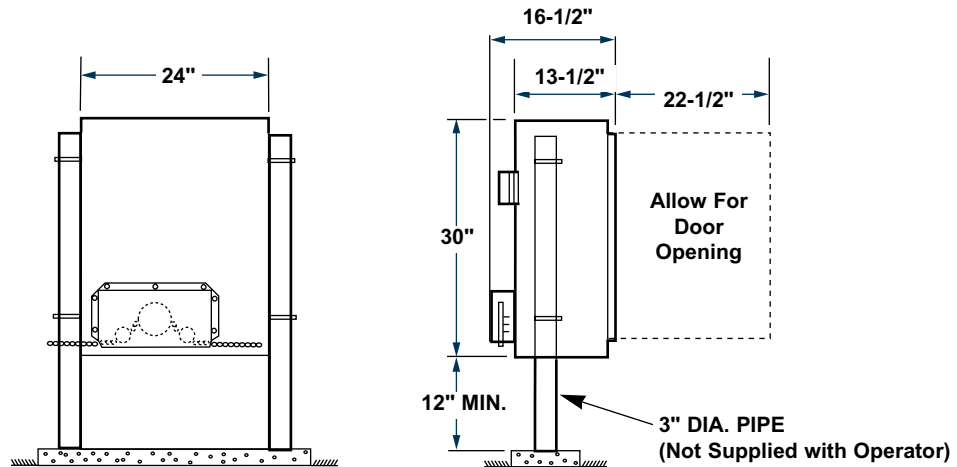



# SAFETY IS EVERYONE'S BUSINESS



## Install the Gate Operator only when:

Vehicular gate systems provide convenience and security. Gate systems are comprised of many component parts. The gate operator is only one component. Each gate system is specifically designed for an individual application. Gate operating system designers, installers and users must take into account the possible hazards associated with each individual application. Improperly designed, installed or maintained systems can create risks for the user as well as the bystander. Gate systems design and installation must reduce public exposure to potential hazards.

A gate operator can create high levels of force, in its function as a component part of a gate system. Therefore, safety features must be incorporated into every design. Specific safety features include:

- Gate Edges
- Enclosed Track
- Vertical Posts
- Screen Mesh
- Photo-electric Sensors
- Instructional & Precautionary Signage
- Guards for exposed rollers

Important instructions follow. These instructions are intended to highlight certain safety related issues. These instructions are not intended to be comprehensive. Because each application is unique, it is the responsibility of the purchaser, designer, installer and end user to ensure that the total gate system is safe for its intended use.

SAFETY INSTRUCTIONS

**SELECT INSTRUCTIONS ARE HIGHLIGHTED WITH THIS PRECAUTIONARY SYMBOL . FAILURE TO FOLLOW THESE SELECTED INSTRUCTIONS CAN RESULT IN SERIOUS INJURY OR DEATH.**

### Step 1: Before Installation

1. Confirm gate operator model is specified by Installation and Maintenance Manual for application type, gate size and frequency of use.
2. Confirm ALL appropriate safety features, such as gate edges, photo-electric sensors, vertical posts and enclosed tracks, are specified.
3. Confirm gate system design reduces pinch points and protects against entrapment.
4. Confirm gate system design has pedestrian access separate from vehicular entrance.
5. Confirm gate system design reduces traffic backup.
6. Confirm warning signage is included in design.
7. Confirm gate moves freely before installation of operator.
8. Repair or service worn or damaged gate hardware before installation of operator.
9. To avoid installation hazards, review the gate system operation and installation procedures, such as manual disconnect mechanism procedure.
10. Confirm control design prohibits unauthorized use.

### Step 2: During Installation

1. Disconnect power at service panel before making any electrical connection.
2. Avoid pinch points; be aware of all moving parts.
3. Adjust clutch or load sensing device to minimum force setting.
4. Do not overtighten clutch or adjust force setting above minimum.
5. Install controls where user cannot touch gate while operating controls.
6. Install controls where user cannot touch gate while operating controls.
7. Install two or more warning signs on the gate to alert persons in the area of automatic gate operation. Warning signs must be conspicuous.
8. Install operator inside fence line. DO NOT install operator on public side of fence line.
9. Secure gate operator cover.

### Step 3: After Installation

1. Test all safety features.
2. Train end user about basic functions and safety features of gate system.
3. Leave Installation and Maintenance Manual and Safety Instructions with end user.

### FOR GATE OPERATORS USING NON-CONTACT SENSOR(S)

1. See instruction supplied with sensor for proper placement.
2. Precautions must be taken to reduce the risk of nuisance tripping of the sensor.
3. If there are multiple areas of risk of entrapment or obstruction, then more than one sensor should be incorporated into the system.

### FOR GATE OPERATORS USING CONTACT SENSOR(S)

1. One or more sensors shall be located as shown on page 5.
2. Care must be taken during the wiring of the sensor(s) to the operator. Make sure that the wiring cannot be damaged or interrupted.
3. When using a sensor with a gate edge transmitter, care must be taken to insure that the RF signal is not interfered with or obstructed.

### SECONDARY ENTRAPMENT PROTECTION

It is recommended that secondary safeties always be used for both the open and close directions. Use photo eyes, safety edges or both. In any case, the device must sense people. Loops cannot be used.



## SAFETY PRECAUTIONS FOR OPEN-ROLLER GATES AND ORNAMENTAL "GRILL TYPE" GATES



### OPEN-ROLLER GATES:

Injuries occur when people get their hands or feet caught between the top or bottom of the gate and the gate roller. This potential pinch-point should be guarded against at all times. Enclosed style gate tracks are available for refitting of these rollers from many fence suppliers. Also, roller guards are available for installing over the rollers.

One or more contact sensors shall be located at the leading edge, trailing edge, and postmounted both inside and outside of a vehicular horizontal slide gate.

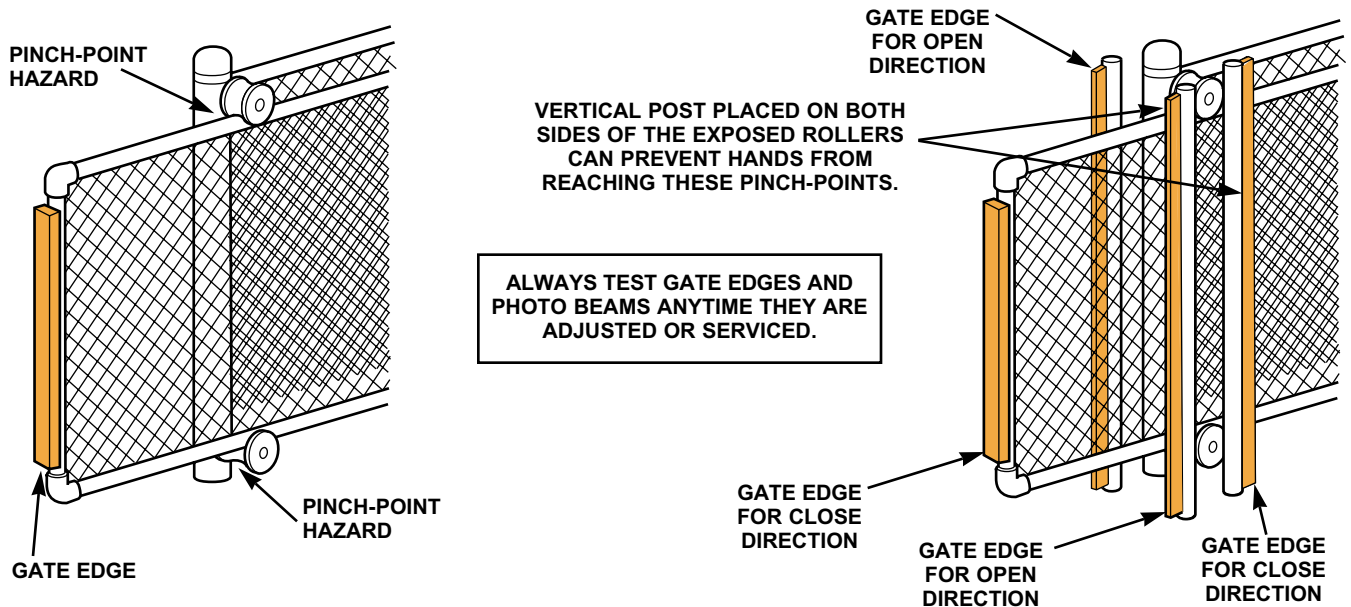
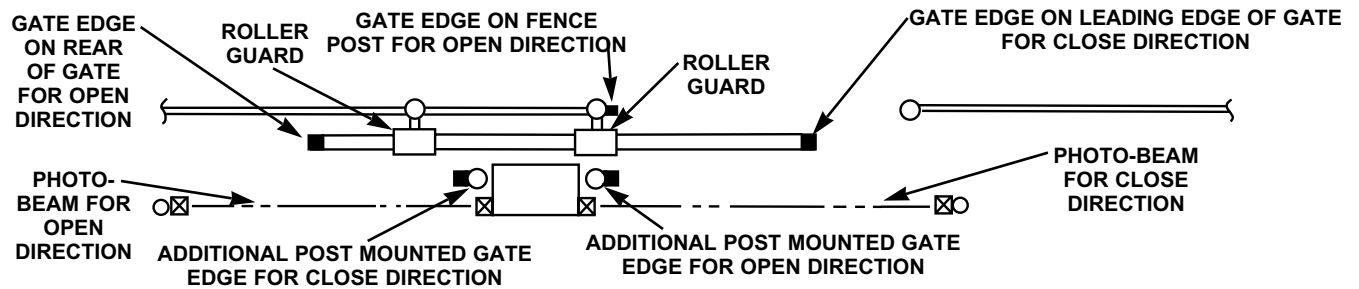

### ORNAMENTAL "GRILL TYPE" GATES:

Injuries occur when people put their hands and arms through openings in the grill and the gate is operated. They cannot retract their arm and it gets caught between the moving gate grill and the stationary fence post or fence. This potential hazard can be averted by placing a 4' screen mesh on the gate to prevent access through openings anywhere the gate may travel. See safety brochure for details.

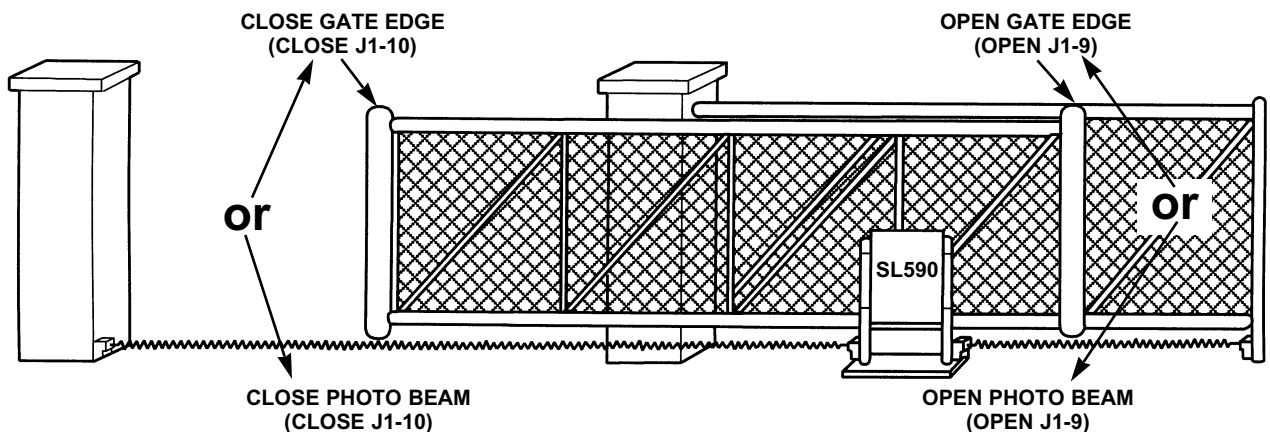

# PRE-INSTALLATION CHECK LIST

- 3 Check the gate. It MUST operate smoothly and freely. If necessary, lubricate, adjust or repair the gate prior to operator installation. The gate MUST be level and plumb.
- 3 Some gates may only be as wide as the gate opening. They may require a backframe to be constructed to allow for chain attachments.
- 3 Double check the size and weight of the gate to make sure that this operator is proper for this application.
- 3 If wiring has already been installed, check to make sure it meets the following specifications and requirements.

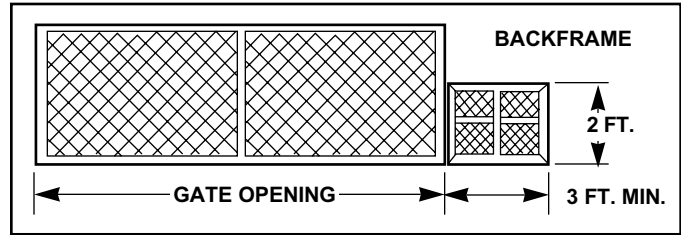

# WIRING SPECIFICATIONS

- A. The distances shown are measured in feet from the operator to the power source.
- B. These calculations are based on the National Electrical Code and allows for a 5% voltage drop.
- C. Supply voltage must be within 10% of the operator's rating under load conditions.
- D. These calculations are based on stranded copper wire.
- E. It is highly recommended that only 90% of the distances shown be used; this will allow for a 10% safety factor.
- F. For dual units, the distance shown should be cut in half.
- G. Permanent wiring is to be employed as required by local codes.
- H. All local codes must be strictly adhered to. It is very important that operator is properly grounded.
- I. Do not run control wires in the same conduit with power wires.
- J. Do not run multi conductor or parallel conductor cable for controls.
- K. All power wiring should be dedicated and protected.

## POWER WIRING CHART

WIRE GAUGE	HP	SINGLE PHASE		3 PHASE		
		115VAC	230VAC	230VAC	460VAC	575VAC
6	1/3	684	3,077	4,737	14,211	35,527
	1/2	473	2,051	2,842	14,211	17,764
	3/4	324	1,231	2,030	7,105	11,842
	1	237	947	1,421	5,684	8,882
	1-1/2	158	648	947	4,060	5,921
	2	—	473	711	2,842	4,441
8	1/3	432	1,942	2,990	8,969	22,422
	1/2	299	1,295	1,794	8,969	11,211
	3/4	204	777	1,281	4,484	7,474
	1	149	597	897	3,587	5,605
	1-1/2	100	409	598	2,562	3,737
	2	—	299	448	1,794	2,803
10	1/3	271	1,218	1,876	5,627	14,068
	1/2	187	812	1,125	5,627	7,034
	3/4	128	487	804	2,814	4,689
	1	94	375	563	2,251	3,517
	1-1/2	62	256	375	1,608	2,345
	2	—	187	281	1,125	1,758
12	1/3	170	763	1,175	3,524	8,810
	1/2	117	509	705	3,524	4,405
	3/4	80	305	503	1,762	2,937
	1	59	235	352	1,410	2,203
	1-1/2	39	161	235	1,007	1,468
	2	—	117	176	705	1,101

**NOTE:** Calculated using NEC guidelines. Local codes and conditions must be reviewed for suitability of wire installation. Master/Slave units must be installed on separate circuits.

CONTROL WIRING		
VOLT	MAXIMUM DIST. (FT.)	WIRE GAGE
24	1000	18

# PRE-INSTALLATION CHECK LIST

- 3 Check the gate. It MUST operate smoothly and freely. If necessary, lubricate, adjust or repair the gate prior to operator installation. The gate MUST be level and plumb.
- 3 Some gates may only be as wide as the gate opening. They may require a backframe to be constructed to allow for chain attachments.
- 3 Double check the size and weight of the gate to make sure that this operator is proper for this application.
- 3 If wiring has already been installed, check to make sure it meets the following specifications and requirements.

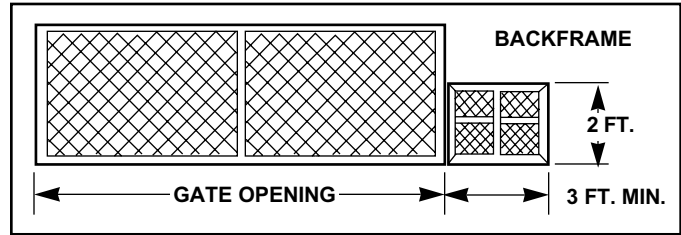

# WIRING SPECIFICATIONS

- A. The distances shown are measured in feet from the operator to the power source.
- B. These calculations are based on the National Electrical Code and allows for a 5% voltage drop.
- C. Supply voltage must be within 10% of the operator's rating under load conditions.
- D. These calculations are based on stranded copper wire.
- E. It is highly recommended that only 90% of the distances shown be used; this will allow for a 10% safety factor.
- F. For dual units, the distance shown should be cut in half.
- G. Permanent wiring is to be employed as required by local codes.
- H. All local codes must be strictly adhered to. It is very important that operator is properly grounded.
- I. Do not run control wires in the same conduit with power wires.
- J. Do not run multi conductor or parallel conductor cable for controls.
- K. All power wiring should be dedicated and protected.

## POWER WIRING CHART

WIRE GAUGE	HP	SINGLE PHASE		3 PHASE		
		115VAC	230VAC	230VAC	460VAC	575VAC
6	1/3	684	3,077	4,737	14,211	35,527
	1/2	473	2,051	2,842	14,211	17,764
	3/4	324	1,231	2,030	7,105	11,842
	1	237	947	1,421	5,684	8,882
	1-1/2	158	648	947	4,060	5,921
	2	—	473	711	2,842	4,441
8	1/3	432	1,942	2,990	8,969	22,422
	1/2	299	1,295	1,794	8,969	11,211
	3/4	204	777	1,281	4,484	7,474
	1	149	597	897	3,587	5,605
	1-1/2	100	409	598	2,562	3,737
	2	—	299	448	1,794	2,803
10	1/3	271	1,218	1,876	5,627	14,068
	1/2	187	812	1,125	5,627	7,034
	3/4	128	487	804	2,814	4,689
	1	94	375	563	2,251	3,517
	1-1/2	62	256	375	1,608	2,345
	2	—	187	281	1,125	1,758
12	1/3	170	763	1,175	3,524	8,810
	1/2	117	509	705	3,524	4,405
	3/4	80	305	503	1,762	2,937
	1	59	235	352	1,410	2,203
	1-1/2	39	161	235	1,007	1,468
	2	—	117	176	705	1,101

**NOTE:** Calculated using NEC guidelines. Local codes and conditions must be reviewed for suitability of wire installation. Master/Slave units must be installed on separate circuits.

CONTROL WIRING		
VOLT	MAXIMUM DIST. (FT.)	WIRE GAGE
24	1000	18

# OPERATOR FEATURES

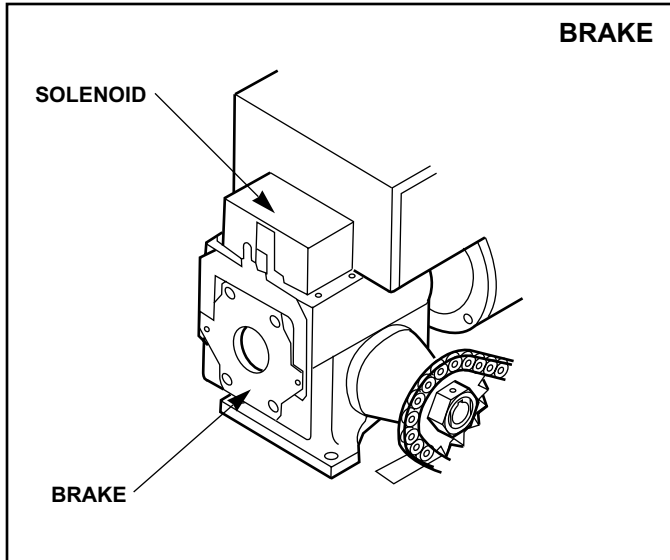

## SOLENOID ACTIVATED BRAKE

The purpose of the brake is to minimize overtravel caused by gate coasting. An added feature of the brake is to assist in preventing backdriving of the gate. The brake is spring applied whenever the motor is not running. Anytime the motor is running the electric solenoid physically releases the brake. It is important that periodically the brake mechanism be checked and adjusted. See maintenance on page 19.

## PRESSURE TYPE SLIPPING CLUTCH

The clutch mechanism used in these operators works similar to that of a clutch in a car. It allows the operator to gradually start the gate moving, rather than trying to instantaneously start moving the gate. This clutch mechanism **MUST** be adjusted properly. When it left the factory it was purposely loosened, so that it will not operate the gate. You **MUST** tighten the clutch spring lock nut so it is tight enough to operate the gate, yet loose enough so that if the gate meets an obstruction the clutch will slip easily. This clutch system will require periodic maintenance, reference the maintenance section on page 19.

**WARNING:** This friction clutch system is not an automatic reversing device. It only serves to minimize damage to the gate operator and gate, also to hopefully minimize vehicle damage. If an external automatic obstruction sensing device is desired, items such as gate edges and photo beams are available to aid in the protection of pedestrians.

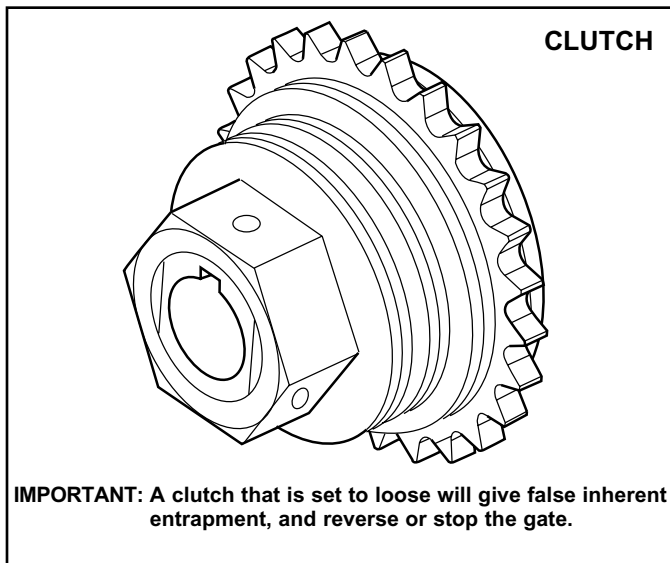

## MANUAL OPERATION

The gate cannot be moved manually when the operator drive mechanism is connected to it. To disconnect the gate from the drive system:

**MODEL SL580** – Slide out the lock bar located underneath the cover and remove the cover. Pull the disconnect chain and engage it in the slot provided. The gate may now be moved manually.

To re-engage the operator, release the chain from the slot. The lock bar has provisions for a padlock to prevent tampering with the operator.

**MODEL SL590** – Open the hinged door and pull the disconnect lever and lock it in place. The gate may now be moved manually.

To re-engage the operator, release the lever and close the door. The door has provisions for a padlock to prevent tampering with the operator.

**NOTE:** or both models, when the operator is under load, you may find it necessary to relieve the tension on the drive chain before disengaging the system.

This may be accomplished by firmly applying pressure in a downward motion to the drive chain with your foot. You may also relieve pressure by rotating the external gear reducer shaft, extending through the brake.

**NOTE:** Manual disconnect does not prevent motor from running.

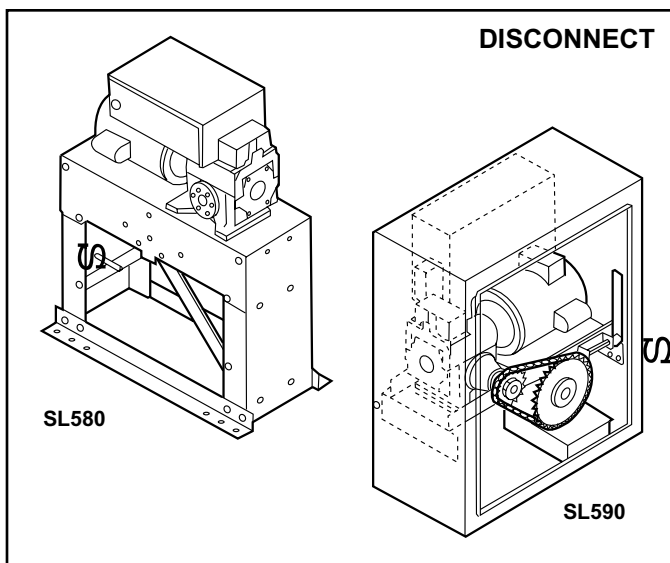

# SYSTEM FEATURES

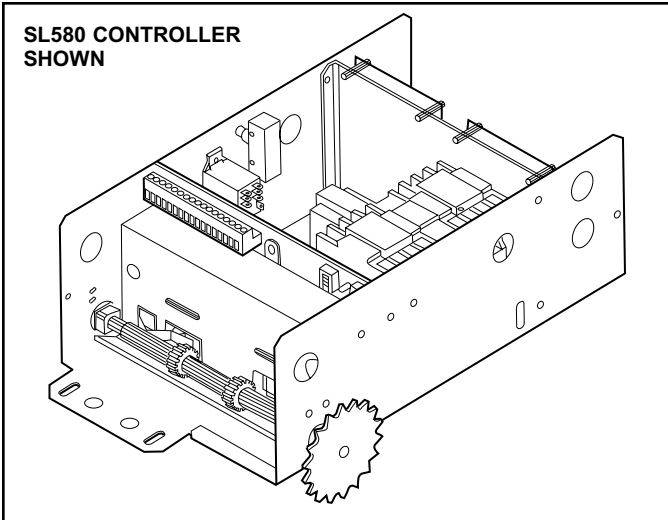

## ACTIVITY LED

- Steady indication when gate is at either open or close limit.
- 1 flash per second when gate is off a limit in normal operation.
- 2 flashes per second when entrapment level one has occurred.

## AUDIBLE WARNING DEVICE

If the operator should have a second inherent obstruction in sequence with the first; i.e. back to back, the sounder will activate for 5 minutes then shut off. Also the sounder can be programmed to come on 2 seconds prior to gate movement and stay on during gate movement.

## THREE BUTTON CONTROL (SEQUENCE OF OPERATION)

Open, stop, close, close is programmable. Stop will override all other functions. If closing, open will cause the operator to stop and reverse to full open. Will close from open limit or midstop only. If SW1 pin 1 is on three button station will only close the operator from the open limit or from mid-stop. If SW1 pin 1 is off, the input will work as a single button (open, close, stop).

### SWITCH #1

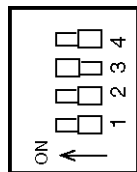

## SINGLE BUTTON CONTROL (SEQUENCE OF OPERATION)

Open to open limit, close open. If power has been interrupted, will always open with first activation.

## CLOSE SINGLE BUTTON SELECT

The one button control can be programmed to either function as a single button control or to function as a close button only.

## DIGITAL MICROPROCESSOR

This is the main circuit board for the operator. It contains all the logic and intelligence for the system. All the system programming is done on this circuit board. See page 14. All solid state, with an emergency back-up system that works even if the processor is missing.

## INHERENT OBSTRUCTION PROTECTION

The limit shaft is equipped with an R.P.M. sensor. When the gate meets an obstruction, the loss of r.p.m's. will cause the gate to reverse. A second obstruction will cause the gate to stop. A renewed wired input will restart the gate.

## EXTERNAL OBSTRUCTION CIRCUIT

This circuit can be used with either a gate edge or a photo beam system. When either of the two devices mentioned are activated, the operator will react in a similar manner to the inherent obstruction described above.

**NOTE:** If external entrapment protection is required by the class of operator, both an open and close protection device must be used.

## SPECIAL NOTE ABOUT OBSTRUCTION SENSING FROM EITHER INTERNAL OR EXTERNAL SYSTEMS

The operator will stop if it senses two sequential obstructions. It will not activate from any automatic system, including the built in time delay to close. Either a manual device such as a pushbutton within site of the gate and operator, or the stop button supplied with the operator must be activated to resume the operator back to its normal operation.

## OPEN ONLY CIRCUIT

Separate open circuits for line-of-sight devices and out-of-sight devices such as open loops or radio controls.

## LOOP CONTROL CIRCUITS

Vehicle control devices such as opening or security loop detectors are connected to this circuit.

## TIME DELAY TO REVERSE CIRCUIT

Allows the gate to come to a complete stop before reversing direction. Approximately 1/2 second between stop and reverse.

**NOTE:** This feature is defeated when either the inherent or external obstruction circuits are activated.

# INSTALLATION – SL580

Please note that there are two basic types of power unit mounting, concrete pad or post mounting. Choose the proper mounting for your specific application. The installation illustrations shown here are for right hand units, for left hand everything will be just the opposite.

If there is existing concrete at the area of power unit mounting, use dimensioning procedure called out in pad mounting instructions. It is suggested that 1/2" threaded anchors (not supplied), be used to secure the unit. If needed, shim the unit to INSURE THAT IT IS LEVEL AND PARALLEL WITH THE GATE!

## CONCRETE PAD – SL580 ONLY

- Layout concrete pad as detailed.
- Locate electrical conduit, as required, prior to pouring concrete.
- Pour concrete, insuring that pad is level and above the ground line.
- Locate four (4) 1/2" threaded anchors, not supplied, as detailed. **IMPORTANT:** Anchors must be positioned accurately and secure in concrete.
- Allow concrete to set for at least two days before installing power unit.

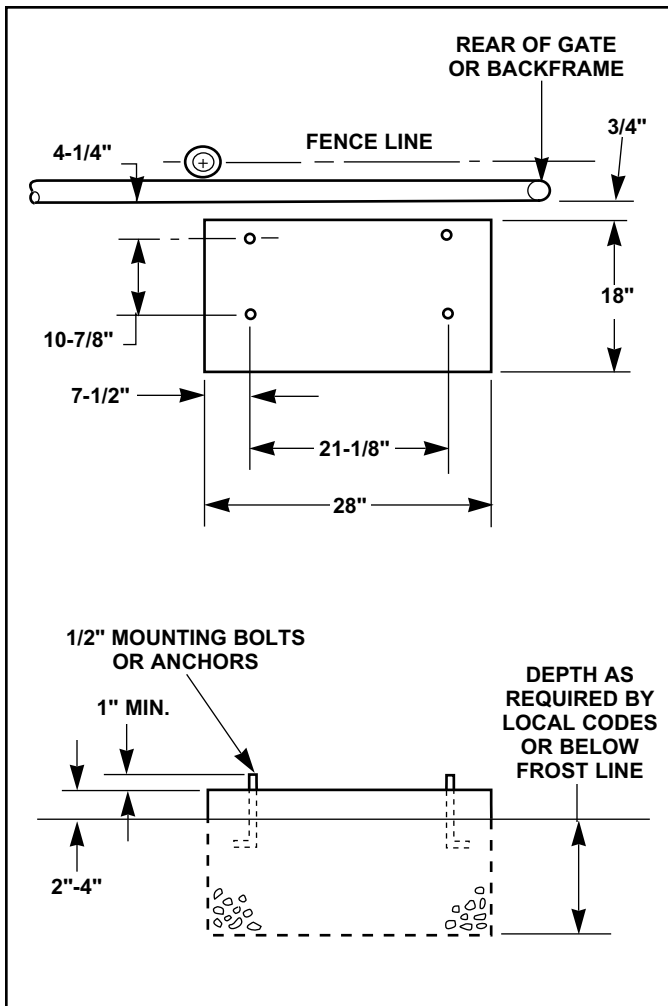

## POST MOUNTING – SL580 ONLY

- Locate and secure two posts, 3" O.D. heavy wall pipe.
- Remove the mounting angles from base of power unit. Use the angles to maintain the proper distance between posts. Secure the angles to the posts using U-bolts.
- Check that:
  - Each post is the same distance from the gate.
  - That the distance between the posts is 24-1/8".
  - The post height is at least 15" from the ground.
  - Tops of posts are level with each other.
- Locate conduit, as required.
- Allow concrete to set at least two days before installing power unit.

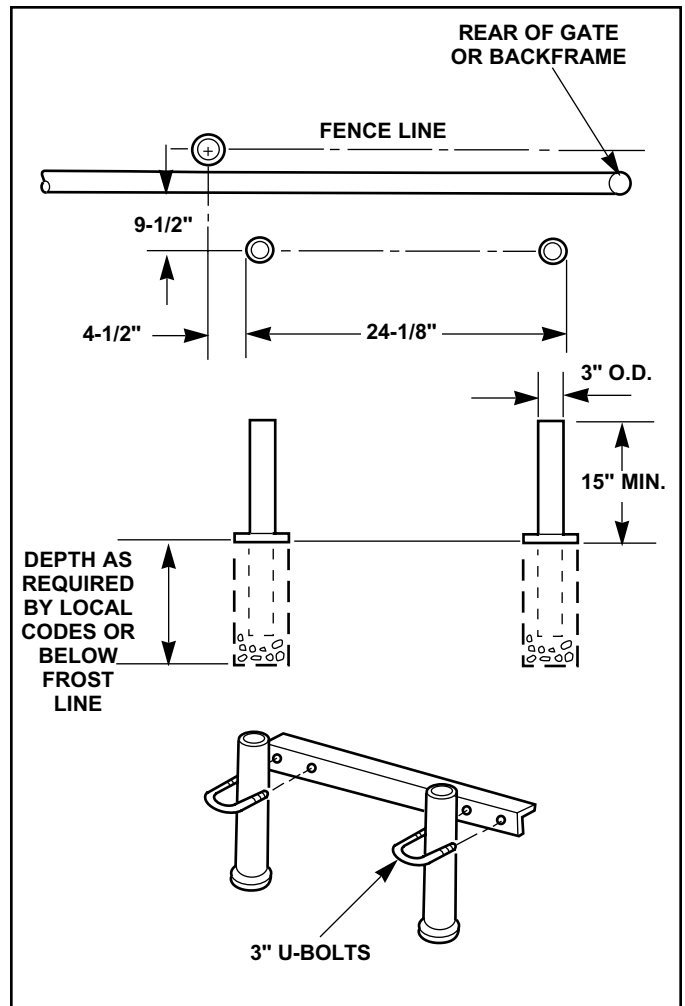

# INSTALLATION – cont. SL580 and SL590

## POST MOUNTING – SL590 ONLY

- A. Locate and secure two posts, 3" O.D. heavy wall pipe.
- B. Check that:
  1. Each post is the same distance from the gate.
  2. That the distance between the posts is 24".
  3. The post height is at least 42" from the ground.
  4. Tops of posts are level with each other.
- C. Locate conduit, as required.
- D. Allow concrete to set at least two days before installing power unit.

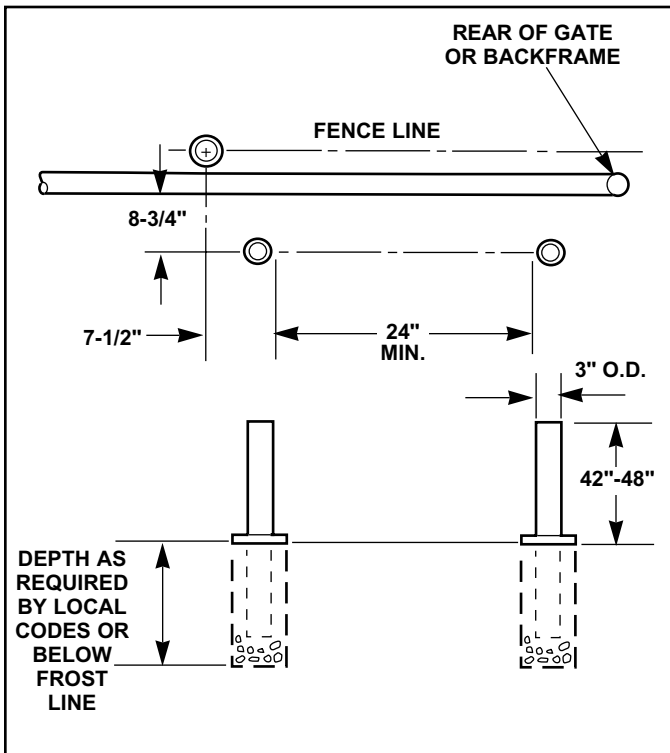

## MOUNTING OPERATOR

**For all mounting styles, it is VERY IMPORTANT that the operator is level and parallel to the gate.**

## PAD MOUNT – SL580 ONLY

After concrete has set, carefully secure operator to concrete pad with drive and idler sprockets facing gate. The 1/2" L-bolts will protrude through the holes in the mounting flanges and should be secured with lockwashers and hex nuts (not provided).

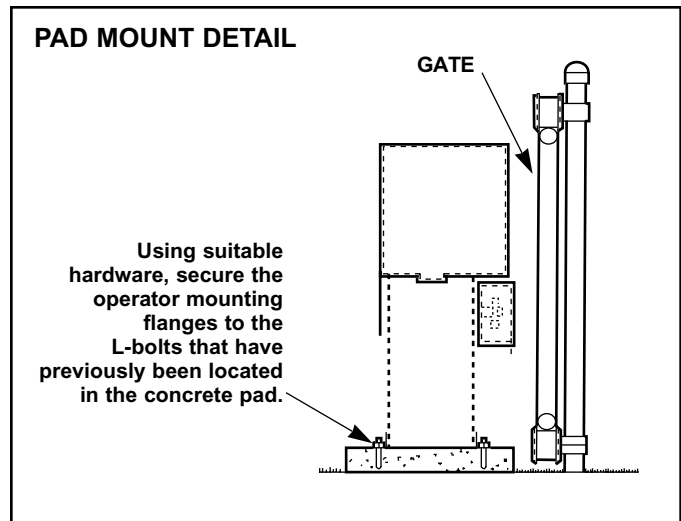

## POST MOUNT

After concrete has set, carefully secure operator to the posts with drive and idler sprockets facing gate. Use the 3" U-bolts and hardware provided. Model SL590 allow a minimum of 12" between ground level and the bottom of operator.

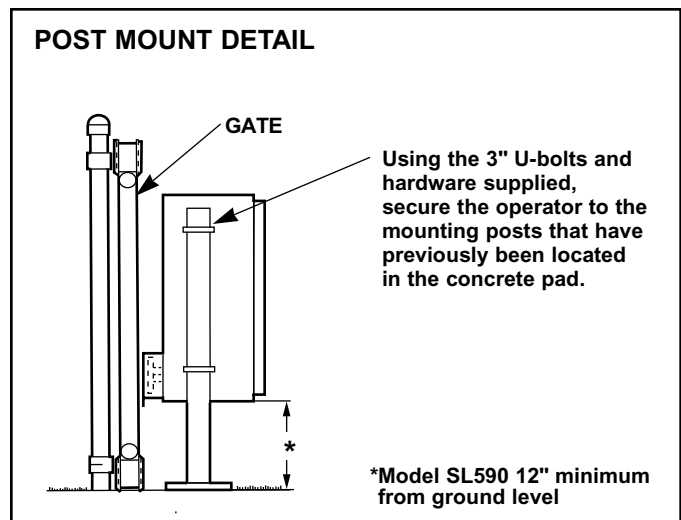

## INSTALLATION – cont.

### GATE BRACKETS

Secure gate bracket to the vertical front and rear posts of the gate. **NOTE:** If a back frame was added, then secure rear gate bracket to the back frame. **IMPORTANT:** The large slotted holes in gate brackets must be level and in line with the bottom of the idler sprockets and each other. Slide the gate to the full open and full closed positions to check alignment.

### DRIVE CHAIN

1. If you have not already done so, remove the operator cover.
2. Locate the engage the manual disconnect lever and lock it in place. Ref. page 7.
3. Connect one chain take-up bolt to the end of the chain and attach to the rear gate bracket. Refer to the bracket detail below.
4. Make sure that the drive and idler sprockets are in-line with each other. Thread the chain through plastic chain guide, around drive and idler sprockets, and then through the second plastic chain guide toward front gate bracket.

**CAUTION:** When pulling the chain through the operator, the limit shaft will turn. Do not drive the limit (nuts) actuators on this shaft past their normal positions.

5. Adjust the chain to proper length and attach second take-up bolt to chain end. Secure the take-up bolt to the front gate bracket as shown below.

**IMPORTANT:** Check alignment of gate brackets to idler sprockets in both vertical and horizontal directions.

6. Adjust nuts on chain take-up bolts to remove chain slack. Leave a maximum of one (1) inch of chain slack for every 10 feet of chain length. **Do not overtighten chain.**
7. It is recommended that the gate brackets be welded to the gate after the chain is properly installed, adjusted, and the operator is functioning.

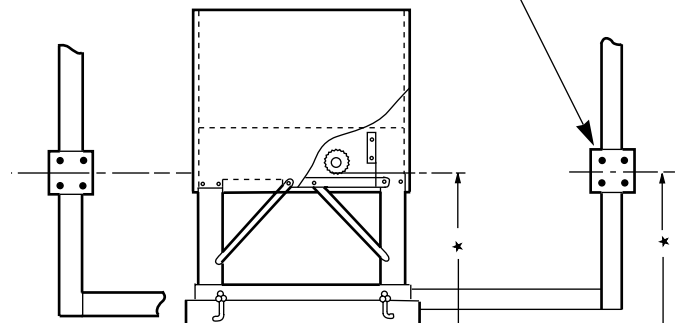
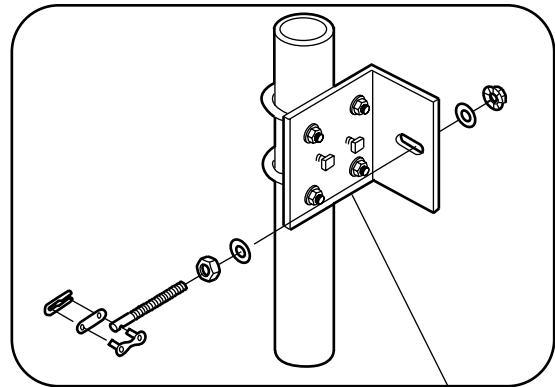
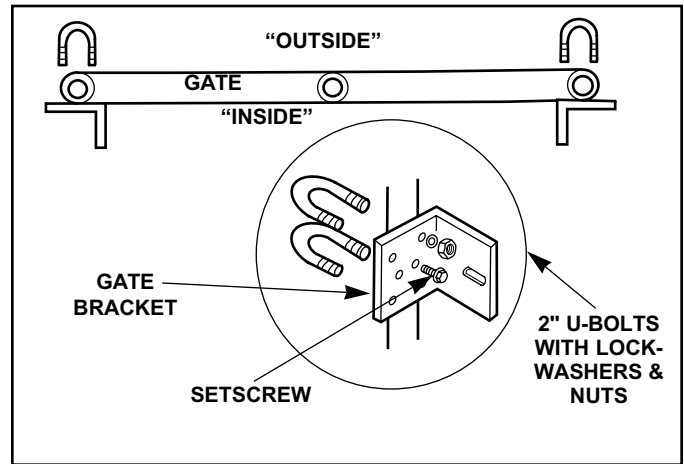

Gate brackets must be level and in line with bottom of idler sprockets.

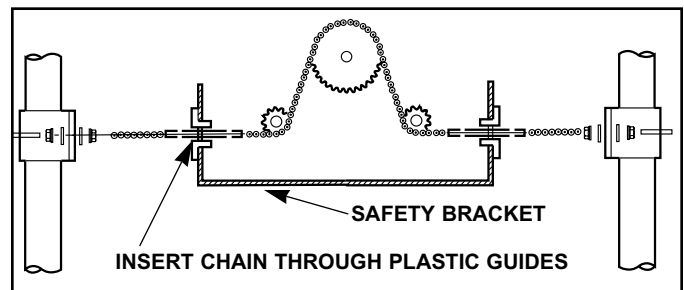

**SUGGESTION:** It is recommended that for gates over 20 feet in length, some type of chain support be added to the gate to prevent excessive chain sag. Note, chain supports must be located a minimum of 3/4" below the idler sprocket shield and must not exceed 3/4" beyond the centerline of the chain.

**NOTE ABOUT SOME TYPES OF CANTILEVER GATES:** With some cantilever gates over 20 feet long, you may need to add a brace along the length of the gate to prevent the gate from bowing with the chain is tightened. This may also be required on some styles of gates that are constructed out of aluminum. **NOTE:** If positioned properly, this brace can also be used as a chain support.



# BEFORE PROCEEDING PLEASE READ THIS



**ELECTRICAL DISCONNECT SWITCH** – Throughout the course of installation you will be required to disconnect electrical power. This can be done by locating the electrical power disconnect switch and turning it on or off as desired.

**MODEL: SL580**

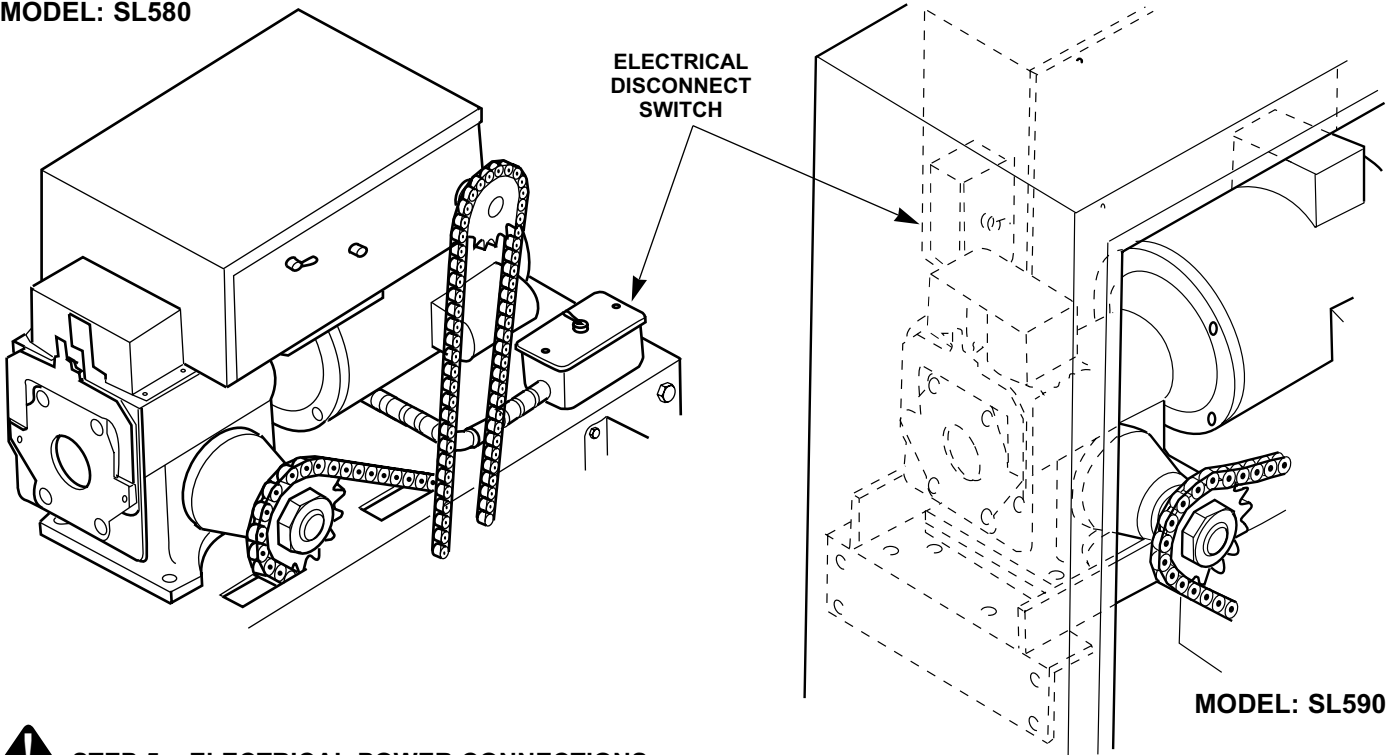

**MODEL: SL590**



## STEP 5 – ELECTRICAL POWER CONNECTIONS

**CAUTION:** MAKE SURE POWER IS DISCONNECTED AT THE MAIN POWER SOURCE AND AT THE OPERATOR'S ELECTRICAL DISCONNECT SWITCH BEFORE PROCEEDING.

A. Secure all electrical power connections inside the power wiring compartment located on the outside end of control panel. Use the electrical wiring diagram supplied with this unit.

All single phase operators will have – L1 (neutral), L2 (hot) and ground.  
All three phase operators will have – L1, L2, L3 and ground.

**IT IS VERY IMPORTANT THAT OPERATOR IS PROPERLY GROUNDED.**

**NOTE:** Permanent wiring is to be employed as required by local codes.

**IMPORTANT:** On three phase operators the power connections must be properly phased. If they are phased wrong the gate operator will run backwards. To correct this situation, disconnect power at main power source and at the operator's electrical disconnect switch. Then, reverse any two of the three power leads.

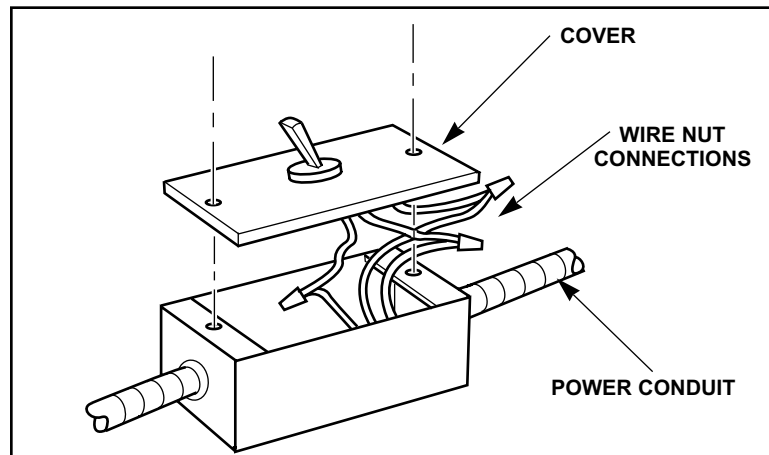

# LIMIT SWITCH ADJUSTMENTS

## LIMIT SWITCH ADJUSTMENTS

- A. By using the mechanical disconnect, manually open the gate to its full open position. (Note direction of limit nut travel.)
- B. Remove control panel cover and locate the rotary limit switch assembly. Disengage the retaining bracket from the limit nuts.
- C. Depending on the hand of the operator, rotate the open limit nut until it makes contact with the open limit switch lever and trips the open limit switch activation button.
- D. Adjust the other limit nut so that it is near the open limit nut but not touching.
- E. Manually close the gate to its full close position.
- F. Disengage the retaining bracket and rotate the close limit nut until it makes contact with the close limit switch lever and trips the close switch.
- G. Re-engage the retaining bracket into both limit nuts and also re-engage the mechanical disconnect.

**NOTE:** Auxiliary (optional) limit switches, to control optional functions, may also be present and should not be confused with the open and close limit switches.

DIRECTION OF GATE TO OPEN	OPEN LIMIT	CLOSE LIMIT
RIGHT	B	A
LEFT	A	B

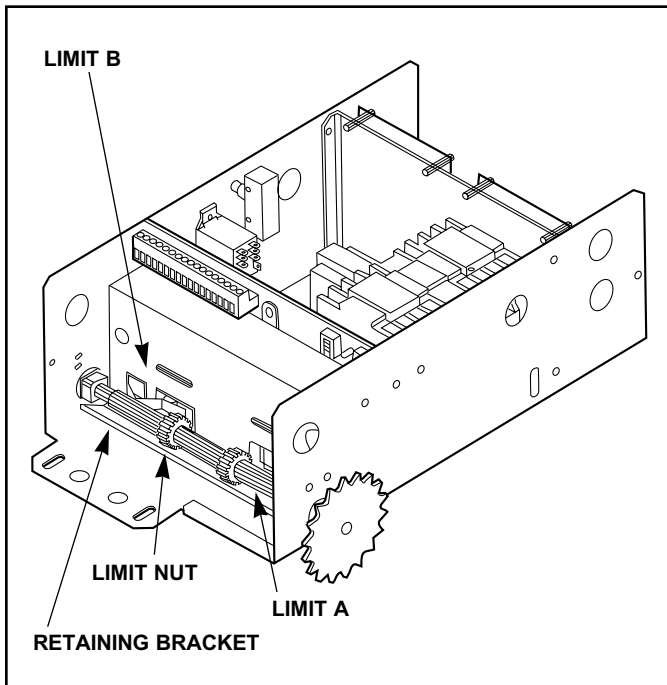

MODEL: SL580

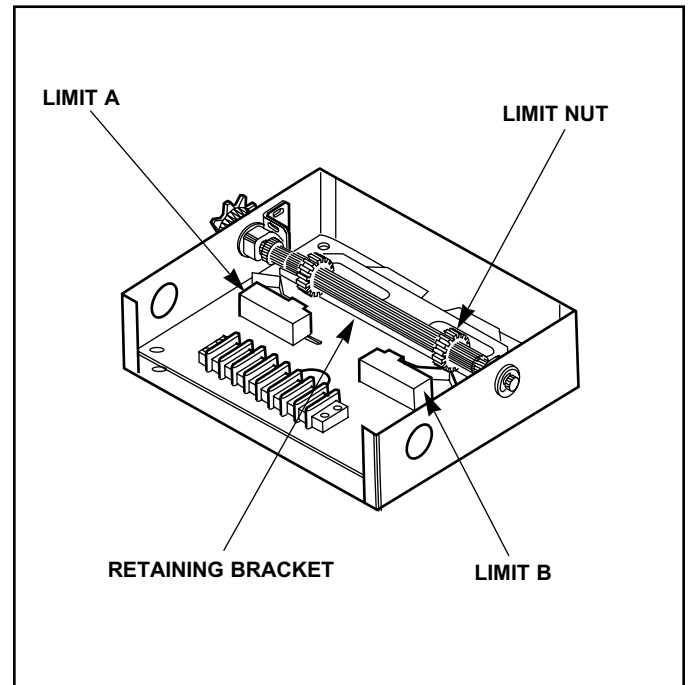

MODEL: SL590

# PROGRAMMING

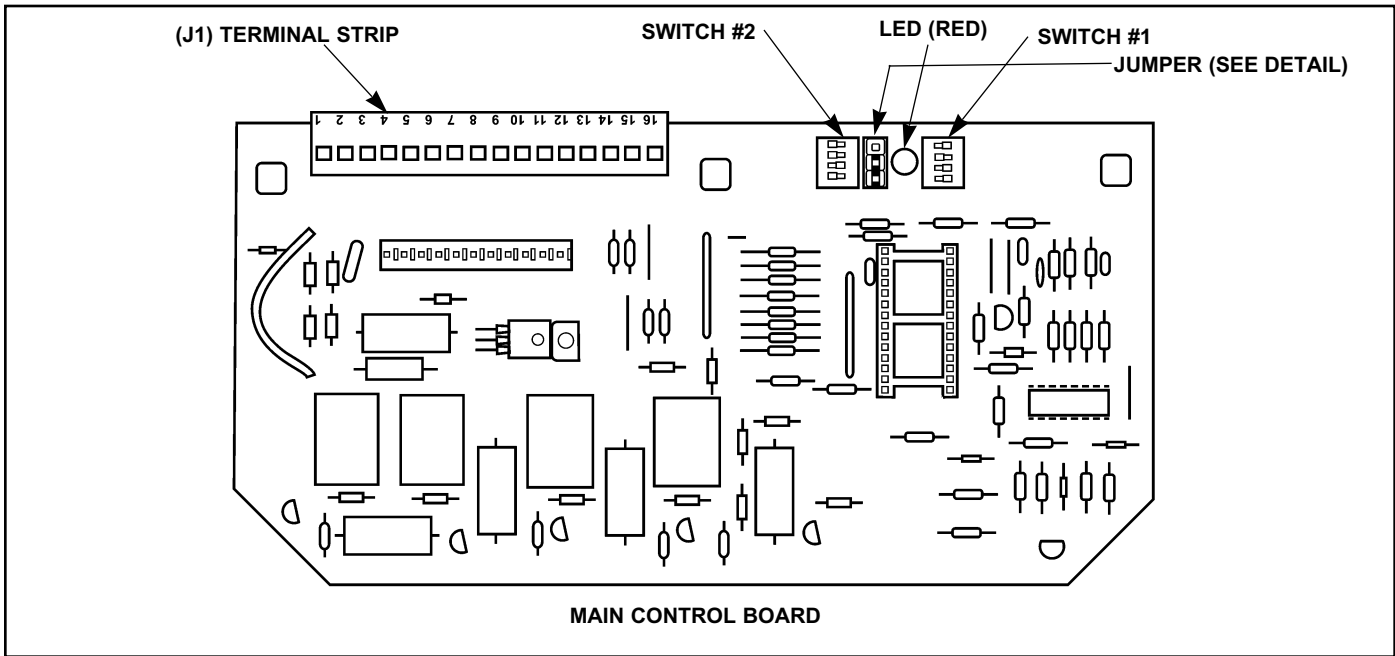

## SWITCH #1 OPERATOR PROGRAMMING

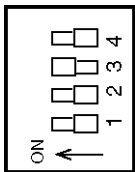

### POLE #1 – SINGLE/CLOSE BUTTON

ON = Close button only  
OFF = Open/Close Button

### POLE #2 – RIGHT HAND / LEFT HAND

ON = Left Hand (gate will open to the left)  
OFF = Right Hand (gate will open to the right)  
(inside of fence looking out)

### POLE #3 – WARNING DEVICE

ON = Warning device will turn on 3 seconds before gate starts to move in either direction.  
OFF = Warning device disabled.

### POLE #4 – MASTER/SLAVE – SINGLE UNIT

ON = Master or Single Unit  
OFF = Slave unit

### RED LED INFORMATION

Continuous ON = Unit is on a limit  
Blinking 1 flash per second = Normal operation (gate travel or mid-stop)  
Blinking 2 flashes per second = Entrapment level 1 (operator reverse to limit)

## SWITCH #2 TIMER TO CLOSE

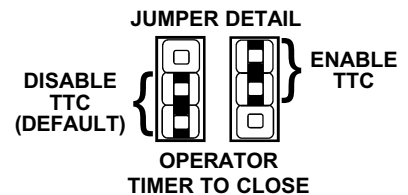
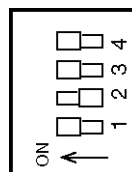

Timer to close is locked out at the factory, to activate the timer to close, move safety jumper from bottom two pins (show illustration) to top two pins. Then set time per the chart below. During normal operation, if the operator stops on a limit, or mid travel, the operator will time out per the chart below and automatically close. To lock the timer to close program and disable, simply return the jumper to the bottom two pins, or turn on all pins of SW#2.

**IMPORTANT: When using master/slave, only set the time for the master operator. The slave operator must be set to disabled position (all poles on).**

Pole #1	Pole #2	Pole #3	Pole #4	Total Time Warning Device Disabled	Total Time Warning Device Enabled
ON	ON	ON	ON	DISABLED	DISABLED
OFF	ON	ON	ON	1 SEC.	4 SEC.
ON	OFF	ON	ON	13 SEC.	16 SEC.
OFF	OFF	ON	ON	26 SEC.	29 SEC.
ON	ON	OFF	ON	40 SEC.	43 SEC.
OFF	ON	OFF	ON	52 SEC.	55 SEC.
ON	OFF	OFF	ON	65 SEC.	68 SEC.
OFF	OFF	OFF	ON	78 SEC.	81 SEC.
ON	ON	ON	OFF	104 SEC.	107 SEC.
OFF	ON	ON	OFF	117 SEC.	120 SEC.
ON	OFF	ON	OFF	129 SEC.	132 SEC.
OFF	OFF	ON	OFF	141 SEC.	144 SEC.
ON	ON	OFF	OFF	155 SEC.	158 SEC.
OFF	ON	OFF	OFF	167 SEC.	170 SEC.
ON	OFF	OFF	OFF	180 SEC.	183 SEC.
OFF	OFF	OFF	OFF	194 SEC.	197 SEC.

# CLUTCH ADJUSTMENT

An adjustable friction type clutch is standard on the models SL580 and SL590. It is **IMPORTANT** that you properly adjust the clutch to obtain proper operator performance.

**CAUTION:** The clutch is not an automatic reversing device. It serves to minimize damage to the gate operator and the gate. It can also limit vehicle damage, if adjusted properly. This operator incorporates an internal obstruction sensor system, but it is highly recommended that external obstruction sensing devices such as gate edges or photo beam systems be incorporated into the gate system to aid in the protection of any possible pedestrian traffic. Periodic inspection of the clutch system and all internal and external sensor systems is required to insure their proper operation.

1. Loosen the 3 set screws on the clutch nut.
2. Back off the clutch nut until there is very little tension on the clutch spring.
3. Tighten the clutch nut gradually until there is just enough tension to permit the operator to move the gate but will allow the clutch to slip if the gate is obstructed. When the clutch is properly adjusted, it should generally be possible to stop the gate by hand during travel.
4. Re-tighten a set screw on the clutch nut that is directly over a flat portion of the shaft.

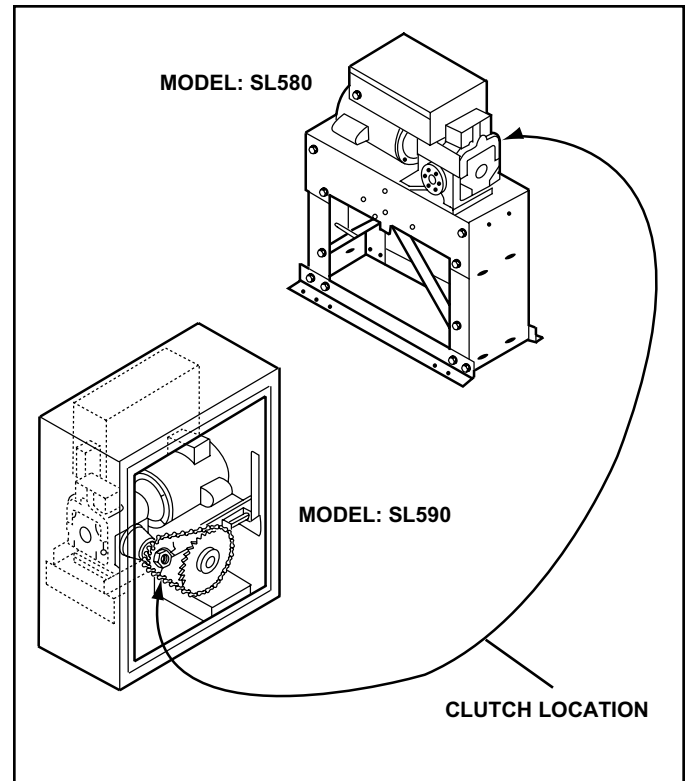
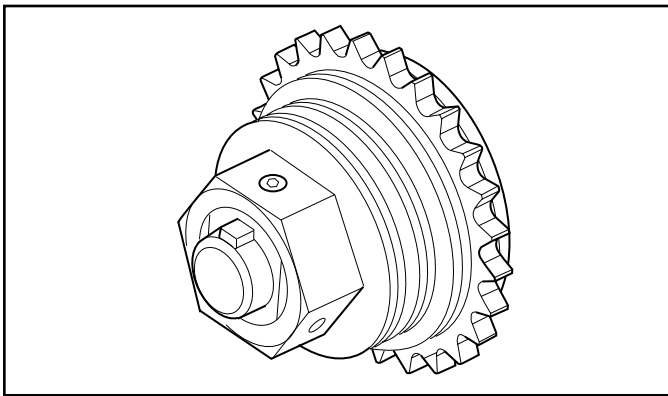

# PRELIMINARY SYSTEM CHECK OUT

Before adding any options, accessories or adaptations, it is highly recommended that you check out the system and its programs. If you have not already done so, temporarily connect a three button station to the operator. Test for proper open, stop and closing of the gate. Test the internal obstruction sensor system. Test for proper operation of all programs that were programmed into the system. Once everything checks out okay, then proceed to adding on the accessory items for this job site. **NOTE:** We recommend that, if more than one accessory item is used, after each one is attached check it for proper operation before adding the next.



**IMPORTANT:** Make sure that the two (2) gate warning signs are secured to the gate. One on the inside and one on the outside. They **MUST** be easily seen.

# CONTROLS AND ACCESSORY INSTALLATION

**\*SEE WIRING DIAGRAM FOR MORE INFORMATION.**

**\*SEE PAGE 6 FOR WIRING DISTANCES AND WIRE GAUGE INFORMATION.**

**WARNING: All controls that are to be used to operate the gate system MUST be installed where the user cannot touch the gate while operating the controls. Also, always install the controls where the user has full view of gate operation.**

All inputs are normally open and momentary, except the stop (NC), and emergency close and emergency open (constant pressure). The following instructions are based upon UL 325, dated March of 1999 and include recommendations for significant increase in safety. We strongly recommend that you follow the UL guidelines presented throughout the manual. Installation device instructions – always follow the instructions provided by the manufacturer when installing and adjusting any control device. If these instructions are contrary to the advice given here, call for assistance.

**(FOR DETAILED OPERATIONS SEE PAGE 8)**



**OPEN BUTTON**

Caution – Only wired devices in sight of the gate may be used with this input. For wireless device see fig. 2.

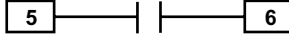

**WIRELESS OPEN BUTTON**

Any device can be used here and the radio (R2) is wired here internally by the factory. Note, on a second obstruction, this input will not function (disabled). See page 8 for details.



**CLOSE/SINGLE BUTTON**

This input allows for either a close operation, or single button. In the single button mode, the feature opens the operator except when on the open limit where it will act as a close.

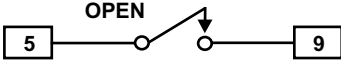

**SAFETY OPEN**

Will reverse (close) the gate if active. If struck again during a reversal the gate will stop.

**SECONDARY SAFETY**

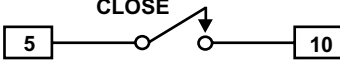

It is recommended that secondary safeties always be used for both the open and close directions.

Use photo eyes, safety edges or both. In any case, the device must sense people. Loops cannot be used.



**SAFETY CLOSE**

Will reverse (open) the gate if active. If struck again during a reversal the gate will stop. May defeat the timer to close.

**SECURITY LOOP**

This input is for vehicles only and does not provide UL secondary safety for persons. This functions as a wireless open unless on the close limit where it is defeated – thus preventing vehicles from entering.

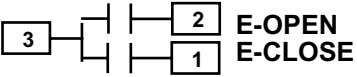

**E-OPEN  
E-CLOSE**

These are constant pressure inputs that bypasses the processor and may be used in an emergency even if the processor fails. Note left/right switch effects direction.



**STOP BUTTON  
– REQUIRED –**

This is a normally closed input and the operator will not run unless this is installed.

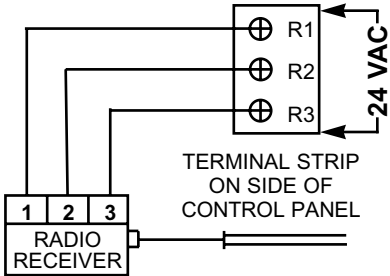

TERMINAL STRIP ON SIDE OF CONTROL PANEL

RADIO RECEIVER

24 VAC

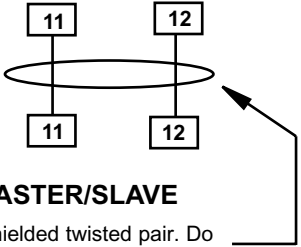

**MASTER/SLAVE**

Use shielded twisted pair. Do not run with power wiring.

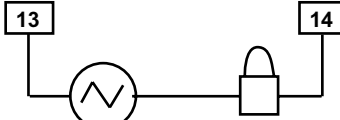

POWER GATE LOCK

USE POWER TO MATCH GATE LOCK REQUIREMENTS, NOT TO EXCEED 115V 10A.

FOR WARNING DEVICES, CALL THE FACTORY

Numbers shown inside a **box** are on the J1 terminal strip on the circuit board.

Connections shown here are field connections. The radio receiver may be ordered factory installed.

# REQUIRED MAINTENANCE – NORMAL USAGE

			Check at least once every			
			1	3	6	12
<b>MONTH INTERVALS</b>						
⚠	Internal speed sensor	Check for proper operation	3			↑ COMPLETE CHECK OUT ↓
⚠	External safety systems	Check for proper operation	3			
⚠	Gate caution signs	Make sure they are present	3			
⚠	Clutch system*	Check & adjust if required		3		
	Brake system	Check & adjust if required			3	
	Manual disconnect	Check & operate			3	
	Drive chain (D) (E)	Check for excessive slack & lubricate			3	
	Sprockets & pulleys	Check for set screw tightness			3	
	Gate	Inspect for wear or damage			3	
	Accessories	Check all for proper operation			3	
	Electrical	Inspect all wire connections			3	
	Frame bolts	Check for tightness			3	
	Total unit	Inspect for wear or damage				

## NOTES:

- ⚠ A. CAUTION – When servicing, always disconnect operator from electrical power supply.
- B. Severe or high cycle usage will require more frequent maintenance checks.
- C. Inspection and service should always be performed anytime a malfunction is observed or suspected.
- D. Limit switches may have to be reset after any major drive chain adjustments.
- E. If lubricating chain, use only a proper chain lub spray or a lightweight motor oil. Never use grease or silicone spray.
- F. When servicing, please do some “house cleaning” of the operator and the area around the operator. Pick up any debris in the area. Clean the operator if needed.
- G. It is suggested that while you are at the site, you take some voltage readings of the operator. Using a VOM, double check the incoming voltage to the operator to make sure it is within ten percent of the operator’s rating.
- H. While you are at the site, now would be a good time to let the owner or manager know about any new items available or any safety items that could and should be added to the site.

**\*IMPORTANT: A clutch that is set too loose will give false, inherent entrapment and reverse or stop the gate.**

# TROUBLESHOOTING



When troubleshooting, one of the first things to do is try to isolate the problem area. The four (4) main areas to check out are:

1. POWER 2. ACCESSORIES 3. OPERATOR'S PRIMARY VOLTAGE 4. OPERATOR'S LOW VOLTAGE CIRCUIT

## 1 POWER



Always use extreme Caution!

Some possible symptoms of power problems:

- The obvious one is, the operator will not run.
- The operator runs slow.
- Circuit breakers or fuses keep tripping.
- Motor overload keeps tripping.
- Operator starts but then stops.

1a. Using a V.O.M. take a voltage reading at the control transformer's primary terminals. You should get a reading as follows:

Nominal volt.	Min.	Max.
120v.	108	132
230v.	207	253
460v.	414	506

If you get a reading that does not fall into the minimum/maximum area, then check out your main power supply. Also, make sure that the operator was ordered with the

proper voltage and phase. Another item to check is the wire run from the power supply to the operator. Double check the gauge of the wire versus the distance.

1b. If the voltage reading is O.K. from 1a, then take the same voltage reading with the operator running. If voltage drops below the minimum with this reading, then there could be an excessive current draw somewhere.

1c. In some cases, power drops can occur at only specific times during the day or night. This can be caused by increased power demands in a general area at a specific time.

## 2 ACCESSORIES

Add-on accessories can create many of the problems that are credited to the operator. Many applications have more than one accessory item attached to the operator and some of these items even draw their power from the operator. So, before we start blaming the operator, let's take a look at all the add-on's first.

Some of the symptoms that can show up because of accessories:

- The operator won't close.
- The operator won't open.
- The operator will not run.
- The operator begins to run then stops or reverses.

2a. Whenever the problem is thought to be an accessory and there are more than one connected to the operator, always disconnect one accessory at a time and then test the system. This will hopefully isolate which item is causing the problem.

2b. If an accessory item is being used as an access control device (used to open or close), falls in the closed position or sends out a continuous signal. The operator will hold the gate in one position until the signal from the accessory is removed.

2c. In some applications, the gate may begin to move then either stop or stop and reverse within a couple of seconds. This can be caused by an external obstruction device that has failed.

2d. If there are many accessories attached to and powered by the operator, there may be too much current draw for the operator's control transformer. This operator can only supply approximately 2 amps @ 24 vac. Double check all accessories for their current requirements.

## 3 PRIMARY VOLTAGE CIRCUIT



Use extreme caution when troubleshooting the primary voltage circuit!

There are five (5) items in this circuit that could be causing trouble, and they are:

- Motor • Transformer • Brake solenoid • Contactor
- Power disconnect switch

3a. The first thing to check is the incoming power. Is it there at the incoming side of the power disconnect switch?

3b. If there is power, then check for it at the transformer primary terminals. If there is voltage at the switch and none at the transformer, then you probably have a bad power disconnect and it should be replaced.

3c. If 3a and 3b check out O.K., then manually disconnect the operator from the gate. VERY CAREFULLY, using a screwdriver with an insulated handle, press down on the open side of the contactor. Then, do the same to the close side of the contactor. Did the operator run in both directions? If it did, the problem may be in the low voltage control circuit. If it did not, then the problem is either in the contactor or the motor.

3d. If the contactor is suspected to be causing the problem, first carefully check all wiring connections at the contacts. DISCONNECT POWER! USING A V.O.M. take continuity readings across the contacts of the contactor. Place one probe on 1 and the other on 2. You should get NO continuity, now press down on the contactor, you should get a continuity reading. Repeat this on all of the contactor's contact points.

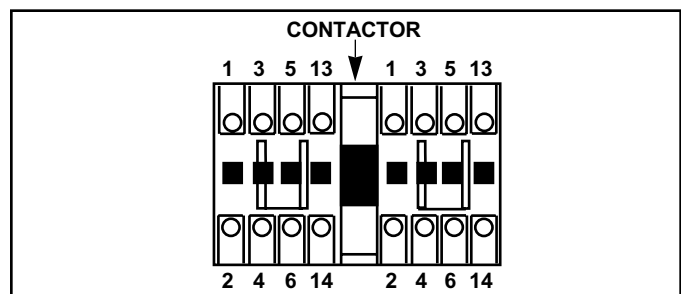

## TROUBLESHOOTING, cont.

- 3e. If the problem is thought to be the motor, it is recommended that it be replaced. It is possible that the thermal overload inside the motor has overheated. Wait approximately 15 minutes, then try running unit. **NOTE:** Some motors have the overload built into the motor itself, while other units have a separate overload in the controller.
- 3f. The brake solenoid will not usually create a problem other than excessive brake pad wear. The solenoid should activate, (pull in), any time the motor is running. Should this not occur, take a voltage reading at the solenoid's connection terminals when the motor is running. You should see a reading of the operators rated voltage  $\pm 10\%$ . If the voltage is present and the solenoid does not activate, then it should be replaced.

### 4 LOW VOLTAGE CIRCUIT

- 4a. The first thing to check is the circuit breaker.
- 4b. The secondary voltage must be between 22 and 30 vac. This voltage can be checked at the circuit board at terminals J1-3 & J1-11.
- 4c. The contactor coils receive 24vac. to activate the motor in either the open or close direction. There are two contactor coils (one for open and one for close).
- 4d. The limit switches are S.P.D.T. (single pole, double throw). These limit switches are what tells the operator to shut off at either the full open or full close position.
- 4e. The R.P.M. Sensor is counting the r.p.m.'s of the wheel that is attached to the shaft. There are no repairable parts for the sensor or wheel. The only thing that should be checked is the wire harness. Make sure that the wires are crimped and fully seated into the housing. Also make sure that the housing is fully seated into the circuit board.
- 4f. The circuit board is the "brains" of the entire system. It is a non-repairable item. In many cases, un-awareness of the different programs and their functions can make it look like there is a problem when in actuality it is just a missed or wrong program setting. Make sure that all the connections wires on the "J1" terminal board are installed correctly. There MUST also be a stop button connected to J1-3 and J1-5.

### H GEAR REDUCER

- If physical signs show a seal has broken in the gear reducer, it may be necessary to replace the reducer.
- When replacing the gear reducer oil, use Mobil SHC 630 or equivalent. The oil level for the gear reducer allow gear to be dipped but not submerged in oil.
- DO NOT overfull gear reducer oil reservoir.

\*Reducer oil – Part #04-DUP220HT

### 1 GENERAL REFERENCE INFORMATION

THE GATE – Double check the gate and its related hardware. Does the gate move freely. If it doesn't, this can affect the internal obstruction sensor.

WIRING DIAGRAM – Always reference the wiring diagram that was supplied with the operator. Note that some of the accessory items may have their own wiring diagram.

If you cannot correct the problem or if you feel you will require technical assistance, the first thing to do is contact your local distributor or dealer. If you do not have a distributor or dealer, then contact us for technical assistance. Please when calling for assistance, make sure you have the gate operator model number, voltage, phase, horsepower and a list of all accessories that are attached to the operator.

H

### FEATURES AND PROGRAM TROUBLESHOOTING REVIEW

H

\*The internal obstruction sensor (r.p.m. sensor) will cause the operator to either stop or reverse if it senses a slow down in gate speed. A damaged or poorly working gate can trip the sensor and cause "phantom" reversing or stopping. Also, if the operator's clutch is slipping too much, this can cause the same situation.



# PARTS LIST

## – MODEL SL580 –

PART NO.	QTY.	DESCRIPTION	PART NO.	QTY.	DESCRIPTION	PART NO.	QTY.	DESCRIPTION
02-401S	1	STOP BUTTON	11-3501	1	DRIVE SHAFT	25-2XXX	1	OVERLOAD (VARIABLE)
03-8024	1	REVERSING CONTACTOR	11-3502	2	IDLER SHAFT	25-4XXX(3PH)	1	OVERLOAD (VARIABLE)
07-5502	1	DISCONNECT HUB	11-3503	2	TAKE-UP BOLT	28-G0518	1	SWITCH BOX
07-5514	1	HUB, TORQUE LIMITER	11-3505	1	DISC. SHAFT	29-09028-2	1	RADIO CONTROL STRIP
07-5515	2	CLUTCH PRESSURE PLATE	11-3506	1	DISC. HANDLE	29-G0486	1	ALARM ASSEMBLY
10-10707	2	SUPPORT BRACKET	11-5206	4	SPRING CUP	305-155514	1	SPROCKET, TORQUE LTR.
10-11045	1	ELEC. BOX MTG. BRACKET	11-5207	4	BRAKE STUD	31-10186	2	SPACER, BRAKE LEVER
10-3209	2	GATE BRACKET	12-4164	6	FLANGE MT. BEARING	31-173	2	LIMIT NUT
10-3501	1	FRAME	12-9031	1	BEARING 3/8"	32-5501-1	1	GEAR REDUCER, 20:1
10-3502	2	LEG CHANNEL	13-14607	1	MOLDED BRAKE HUB	39-5504	2	CLUTCH DISC.
10-3503	1	BOTTOM COVER	13-3510	4	CHAIN GUIDE	41-G0538	1	SPACER
10-3504	2	MTG. ANGLE	15-3516	1	DRIVE SPROCKET, 50B16	42-8116-1	1	TERMINAL BLOCK
10-3505(N)	1	OPERATOR COVER	15-9020	2	IDLER SPROCKET, 50B12	42-G0509	1	TERMINAL BLOCK 7 POS.
10-3509	(5)	REINFORCING BAR	18-10194	4	COMPRESSION SPRING	69-G2000	1	53 BOARD
10-3510	1	LOWER CHAIN GUARD	18-10467	1	COMPRESSION SPRING	71-416-7NH	1	24V LOOP BOARD
10-3511	1	LOCKBAR	19-511	1	DISC. SPRING	(OPTIONAL)		
10-3512	1	LOCKBAR GUIDE	18-5514	4	BELLEVILLE WASHER	74-G0487	1	SPEED SENSOR
10-3515	2	GUIDE RETAINER	19-3025	1	25' CHAIN PACKAGE	75-075502	1	DISC. KIT
10-3522	2	SHIM	19-3501	1	DRIVE CHAIN, #40	80-207-19	3	KEY, 1/4 X 1-1/2
10-3523	1	DISCONNECT CAM	19-48073	1	LIMIT CHAIN, #48	80-207-35	2	KEY, ROUND ENDS
10-3526	1	CONTROL BOX ENC.	19-48ML	1	MASTER LINK, #48	80-207-36	1	KEY, 1/4 X 1-1/4
10-3527	1	LOOP BRACKET	19-5040	1	MASTER LINK, #40	82-PX08-06T	2	SCREW
10-5206	1	BRAKE RELEASE LEVER	19-9010-2	1	DISC. CHAIN	82-QN43-12	4	SET SCREW
10-5207	1	SOLENOID COVER	19-9024-NP	2	MASTER LINK #50	84-JH-150S	1	HEX JAM NUT 1-1/2 - 12
10-5209	1	BRAKE DISC.	20-XXXX	1	MOTOR (VARIABLE)	87-E-100	1	SNAP RING, 1"
10-7020	1	S2 BOARD MTG. BRACKET	21-XXXX	1	TRANSFORMER (VAR.)	91-G0142	1	BRAKE PLATE ASSY.
10-7022	1	DEPRESS PLATE	22-XXX	1	BRAKE SOLENOID (VAR.)	91-G0143	1	SPROCKET ASSY. 40B34
10-9011	1	YOKE	23-2016	2	LIMIT SWITCH OP/CL.	91-G0146	1	LIMIT SPROCKET
10-3528(N)	1	COVER, ELEC. ENCL.	23-3XXX	1	ON/OFF SWITCH (VAR.)	91-G0382	1	BRAKE PLATE ASSY.
10-G0326	1	SWITCH BOX COVER	24-XXXXX	1	IR RELAY (VARIABLE)	91-G0530	1	LIMIT SHAFT ASSY.

PARTS DESIGNATED (N) ARE NOT SHOWN ON DRAWING.  
 PARTS HAVING ONE OR MORE X IN THE PART NO. VARY FROM MODEL TO MODEL. SEE "VARIABLE PARTS" BELOW.  
 PARTS DESIGNATED (3PH) ARE PRESENT ON 3PH OPERATORS ONLY.  
 QUANTITIES SHOWN IN PARENTHESES ARE USED ONLY ON 1 AND 1-1/2 HP OPERATORS.

### VARIABLE PARTS

VARIABLE	P/N	DESCRIPTION	USED ON
20-XXXX	20-1050-T	MOTOR, 1/2HP, 115/230-1PH	SL580-50-11, SL580-50-21
	20-1075-T	MOTOR, 3/4HP, 115/230-1PH	SL580-75-11, SL580-75-21
	20-1100-T	MOTOR, 1 HP, 115/230-1PH	SL580-100-11, SL580-100-21
	20-1150-T	MOTOR, 1-1/2 HP, 115/230-1PH	SL580-150-11, SL580-150-21
	20-3050-T	MOTOR, 1/2HP, 230/460-3PH	SL580-50-23, SL580-50-43
	20-3075-T	MOTOR, 3/4HP, 230/460-3PH	SL580-75-23, SL580-75-43
	20-3100-T	MOTOR, 1HP, 230/460-3PH	SL580-100-23, SL580-100-43
21-XXXX	20-3150-T	MOTOR, 1-1/2HP, 230/460-3PH	SL580-150-23, SL580-150-43
	21-3260	120-208-240-460/24V, 50VA	ALL 230V-1PH & 3PH
	21-5115	115/24, 40VA	ALL 115V-1PH
22-XXX	21-10298	575V, 3PH	ALL 575V-3PH
	22-120	SOLENOID, 115V	ALL 115-1PH
23-XXXX	22-240	SOLENOID, 230V	ALL 230-1PH & 3PH, 460V-3PH
	23-3001	ON/OFF SW. 1PH	ALL 1PH
24-XXX-X	23-3005	ON/OFF SW. 3PH	ALL 3PH
	24-115-1	RELAY, TPDT. 115V COIL (IR)	ALL 115V 1PH
25-20XX	24-230-5	RELAY, TPDT. 230V COIL (IR)	ALL 230V 1PH
	25-2006	MOTOR PROTECTOR, 6 AMP	SL580-50-21
	25-2008	MOTOR PROTECTOR, 8 AMP	SL580-75-21, SL580-100-21
	25-2010	MOTOR PROTECTOR, 10 AMP	SL580-50-11, SL580-150-21
	25-2015	MOTOR PROTECTOR, 15 AMP	SL580-75-11
	25-2020	MOTOR PROTECTOR, 20 AMP	SL580-100-11
	25-2025	MOTOR PROTECTOR, 25 AMP	SL580-150-11
25-40XX(3PH)	25-4002-5	OVERLOAD, 1.6-2.5 AMP	SL580-100-43
	25-4004	OVERLOAD, 2.5-4.0 AMP	SL580-150-43
	25-4006	OVERLOAD, 4.0-6.0 AMP	SL580-100-23
	25-4008	OVERLOAD, 5.5-8.0 AMP	SL580-150-23

# PARTS LIST – SL590

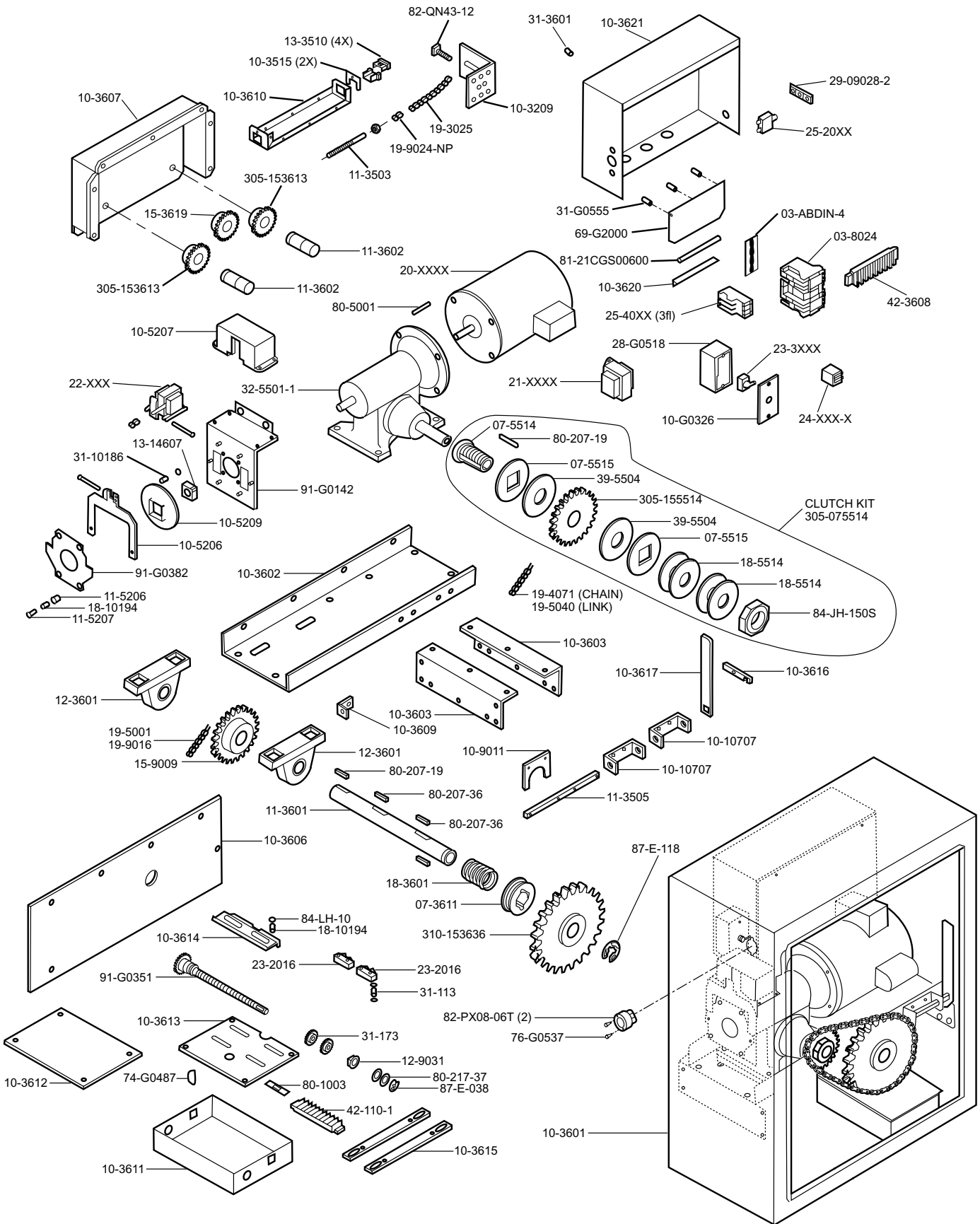

# PARTS LIST

## – MODEL SL590 –

PART NO.	QTY.	DESCRIPTION	PART NO.	QTY.	DESCRIPTION	PART NO.	QTY.	DESCRIPTION
02-401S(N)	1	STOP BUTTON	11-3503	2	TAKE-UP BOLT	29-09028-2	1	RADIO CONTROL STRIP
03-8024	1	REV. CONTACTOR	11-3505	1	DISC. SHAFT	305-153613	2	IDLER SPROCKET ASSY.
03-ABDIN-4	1	DIN RAIL	11-3601	1	DRIVE SHAFT	305-155514	1	SPROCKET, TORQUE LMTR.
07-3611	1	DISCONNECT HUB	11-3602	2	IDLER SHAFT	310-153636	1	SPROCKET ASSY. 40B36
07-5514	1	HUB, TORQUE LIMITER	11-5206	4	SPRING CUP	31-10186	2	SPACER, BRAKE LEVER
07-5515	2	CLUTCH PRES. PLATE	11-5207	4	BRAKE STUD	31-113	4	SPACER #6 X 3/8"
10-10707	2	SUPPORT BRACKET	12-3601	2	PILLOW BLOCK BEARING	31-173	2	LIMIT NUT
10-3209	2	GATE BRACKET	12-9031	1	BEARING 3/8"	31-3601	4	COUPLING, 1/4-20
10-3515	2	GUIDE RETAINER	13-14607	1	BRAKE HUB	31-G0555	1	STANDOFF HEX ALUMINUM
10-3601	1	OPERATOR ENCLOSURE	13-3510	4	CHAIN GUIDE	31-G0556	2	STANDOFF HEX NYLON
10-3602	1	FRAME	15-3619	1	DRIVE SPROCKET, 50B19	32-5501-1	1	GEAR REDUCER, 20:1
10-3603	2	SUPPORT BRACKET	15-5514	1	TORQUE LIMIT 40A25 SP 1/2	39-5504	2	CLUTCH DISC.
10-3606	1	LOAD PLATE	15-9009	1	SPROCKET, 48B18	42-110-1	1	TERMINAL BLOCK
10-3607	1	CHAIN COVER	18-10194	6	COMPRESSION SPRING	42-3608	1	TERMINAL BLOCK
10-3609	1	ANGLE PLATE	18-3601	1	DISCONNECT SPRING	69-G2000	1	S3 BOARD
10-3610	1	CHAIN GUARD	18-5514	4	BELLEVILLE WASHER	74-G0487	1	SPEED SENSOR
10-3611	1	LIMIT SWITCH ENCLOSURE	19-3025	1	#50 DRIVE CHAIN, 25'	76-G0537	1	ALARM ASSEMBLY
10-3612	1	COVER, LIMIT ENCL.	19-4071	1	DRIVE CHAIN #40	80-1003	4	TINNERMAN NUT
10-3613	1	LIMIT SWITCH PANEL	19-5001	1	LIMIT CHAIN, #48	80-207-19	2	KEY, 1/4 X 1-1/2
10-3614	1	DEPRESS PLATE	19-5040	1	MASTER LINK, #40	80-207-36	3	KEY, 1/4 X 1-1/4
10-3615	2	LIMIT BOX BRACKET	19-9016	1	MASTER LINK, #48	80-217-37	1	SPACER, 3/8"
10-3616	1	DETENT PLATE	19-9024-NP	2	MASTER LINK, #50	80-5001	1	KEY 3/16x3/16x1-3/4" LONG
10-3617	1	DISCONNECT LEVER	20-XXXX	1	MOTOR (VARIABLE)	81-21CGS00600	1	6" CARD GUIDE
10-3620	1	S3 MOUNTING BRACKET	21-3260	1	120-208-240-460/24V, 50VA	82-QN43-12	4	SET SCREW
10-3621	1	ELECTRICAL ENCL.	22-XXX	1	BRAKE SOLENOID (VAR.)	84-JH-150S	1	HEX JAM NUT, 1-1/2 - 12
10-3622(N)	1	COVER, ELEC. ENCL.	23-2016	2	LIMIT SWITCH, OP/CL	84-LH-10	2	LOCKNUT
10-5206	1	BRAKE RELEASE LEVER	23-3XXX	1	ON/OFF SWITCH (VAR)	87-E-038	1	SNAP RING, 3/8"
10-5207	1	SOLENOID COVER	24-XXX-X	1	RELAY (VARIABLE)	87-E-118	1	SNAP RING
10-5209	1	BRAKE DISC.	25-20XX	1	OVERLOAD (VARIABLE)	91-G0142	1	BRAKE PLATE ASSY.
10-9011	1	YOKE	25-40XX (3PH)	1	OVERLOAD (VARIABLE)	91-G0351	1	LIMIT SHAFT ASSY.
10-G0326	1	SWITCH BOX COVER	28-G0518	1	SWITCH BOX	91-G0382	1	BRAKE PLATE ASSY.

PARTS DESIGNATED (N) ARE NOT SHOWN ON DRAWING.  
 PARTS HAVING ONE OR MORE X IN THE PART NO. VARY FROM MODEL TO MODEL. SEE "VARIABLE PARTS" BELOW.  
 PARTS DESIGNATED (3PH) ARE PRESENT ON 3PH OPERATORS ONLY.

### VARIABLE PARTS

VARIABLE	P/N	DESCRIPTION	USED ON
	20-XXXX	MOTOR, 1/2HP, 115/230V-1PH	SL590-50-11, SL590-50-21
		MOTOR, 3/4HP, 115/230V-1PH	SL590-75-11, SL590-75-21
		MOTOR, 1 HP, 115/230V-1PH	SL590-100-11, SL590-100-21
		MOTOR, 1-1/2 HP, 115/230V-1PH	SL590-150-11, SL590-150-21
		MOTOR, 1/2HP, 230/460V-3PH	SL590-50-23, SL590-50-43
		MOTOR, 3/4HP, 230/460-3PH	SL590-75-23, SL590-75-43
		MOTOR, 1HP, 230/460-3PH	SL590-100-23, SL590-100-43
		MOTOR, 2HP, 230/460-3PH	SL590-150-23, SL590-150-43
	21-XXXX	120-208-240-460/24V, 50VA	ALL 230V-1PH & 3PH
		115/24, 40VA	ALL 115V-1PH
		575V, 3PH	ALL 575V-3PH
	22-XXX	SOLENOID, 115V	ALL 115-1PH
		SOLENOID, 230V	ALL 230-1PH & 3PH, 460V-3PH
		SOLENOID, 575V	ALL 575V-3PH
	23-XXXX	ON/OFF SW. 1PH	ALL 1PH
		ON/OFF SW. 3PH	ALL 3PH
	24-XXX-X	RELAY, TPDT, 115V COIL (IR)	ALL 115V 1PH
		RELAY, TPDT, 230V COIL (IR)	ALL 230V 1PH
	25-20XX	MOTOR PROTECTOR, 6 AMP	SL590-50-21
		MOTOR PROTECTOR, 8 AMP	SL590-75-21, SL590-100-21
		MOTOR PROTECTOR, 10 AMP	SL590-50-11, SL590-150-21
		MOTOR PROTECTOR, 15 AMP	SL590-75-11
		MOTOR PROTECTOR, 20 AMP	SL590-100-11
		MOTOR PROTECTOR, 25 AMP	SL590-150-11
	25-40XX (3PH)	OVERLOAD, 1.6-2.5 AMP	SL590-100-43
		OVERLOAD, 2.5-4.0 AMP	SL590-150-43
		OVERLOAD, 4.0-6.0 AMP	SL590-100-23
		OVERLOAD, 5.5-8.0 AMP	SL590-150-23

# Sentex Systems

---

9800 DeSoto Ave., Chatsworth, CA 91311  
e-mail address: <http://www.sentexsystems.com/index.html>

## WARRANTY POLICY

Seller warrants that the goods are free from defect in materials and/or workmanship for a period of one year from the date of shipment from the F.O.B. point. Goods returned to Seller for warranty repair within the warranty period, which upon receipt by Seller are confirmed to be defective and covered by this limited warranty, will be repaired or replaced (at Seller's sole option) at no cost and returned pre-paid. Defective parts will be repaired or replaced with new or factory-rebuilt parts at Seller's sole option. Authorization instructions for the return of any goods must be obtained by Buyer from Seller before returning the goods. The goods must be returned with complete identification, freight prepaid, and in accordance with Seller's instructions or they will not be accepted. In no event will Seller be responsible for goods returned without proper authorization or identification

THIS LIMITED WARRANTY IS IN LIEU OF ANY OTHER WARRANTIES, EXPRESS OR IMPLIED, INCLUDING ANY IMPLIED WARRANTY OF MERCHANTABILITY OR FITNESS FOR A PARTICULAR PURPOSE, OR OTHERWISE, AND OF ANY OTHER OBLIGATIONS OR LIABILITY ON SELLER'S PART. THIS LIMITED WARRANTY DOES NOT COVER NON-DEFECT DAMAGE, DAMAGE CAUSED BY IMPROPER INSTALLATION, OPERATION OR CARE (INCLUDING, BUT NOT LIMITED TO ABUSE, MISUSE, FAILURE TO PROVIDE REASONABLE AND NECESSARY MAINTENANCE, OR ANY ALTERATIONS TO THIS PRODUCT), LABOR CHARGES FOR DISMANTLING OR REINSTALLING A REPAIRED OR REPLACED UNIT, OR REPLACEMENT BATTERIES. UNDER NO CIRCUMSTANCES SHALL SELLER BE LIABLE FOR CONSEQUENTIAL, INCIDENTAL OR SPECIAL DAMAGES ARISING IN CONNECTION WITH THE USE, OR INABILITY TO USE, THIS PRODUCT. IN NO EVENT SHALL SELLER'S LIABILITY FOR BREACH OF WARRANTY, BREACH OF CONTRACT, NEGLIGENCE OR STRICT LIABILITY EXCEED THE COST OF THE PRODUCT COVERED HEREBY. NO PERSON IS AUTHORIZED TO ASSUME FOR US ANY OTHER LIABILITY IN CONNECTION WITH THE SALE OF THIS PRODUCT. Some states do not allow the exclusion or limitation of consequential, incidental or special damages, so the above limitation or exclusion may not apply to you. This limited warranty gives you specific legal rights, and you may also have other rights which vary from state to state.

**Your professional Sentex dealer is:**