

# **Hy-Security Gate Operators**

## **HYDRAULIC SWING GATE Operators**

**With Smart Touch Controller**

### **Installation and Maintenance Manual**

HRG 220 ST, HRG 222 ST  
and  
DC Battery UPS version

Revision: \_\_\_\_



**Hy-Security Gate Operators**

*Phone: 1-800-321-9947*

*FAX: (206) 286-0614*

*Internet: [www.hy-security.com](http://www.hy-security.com)*

*Email: [Info@hy-security.com](mailto:Info@hy-security.com)*

INSTR# 108

Date 04/01/02



# Hydraulic Swing Gate Operator

With Smart Touch Controller

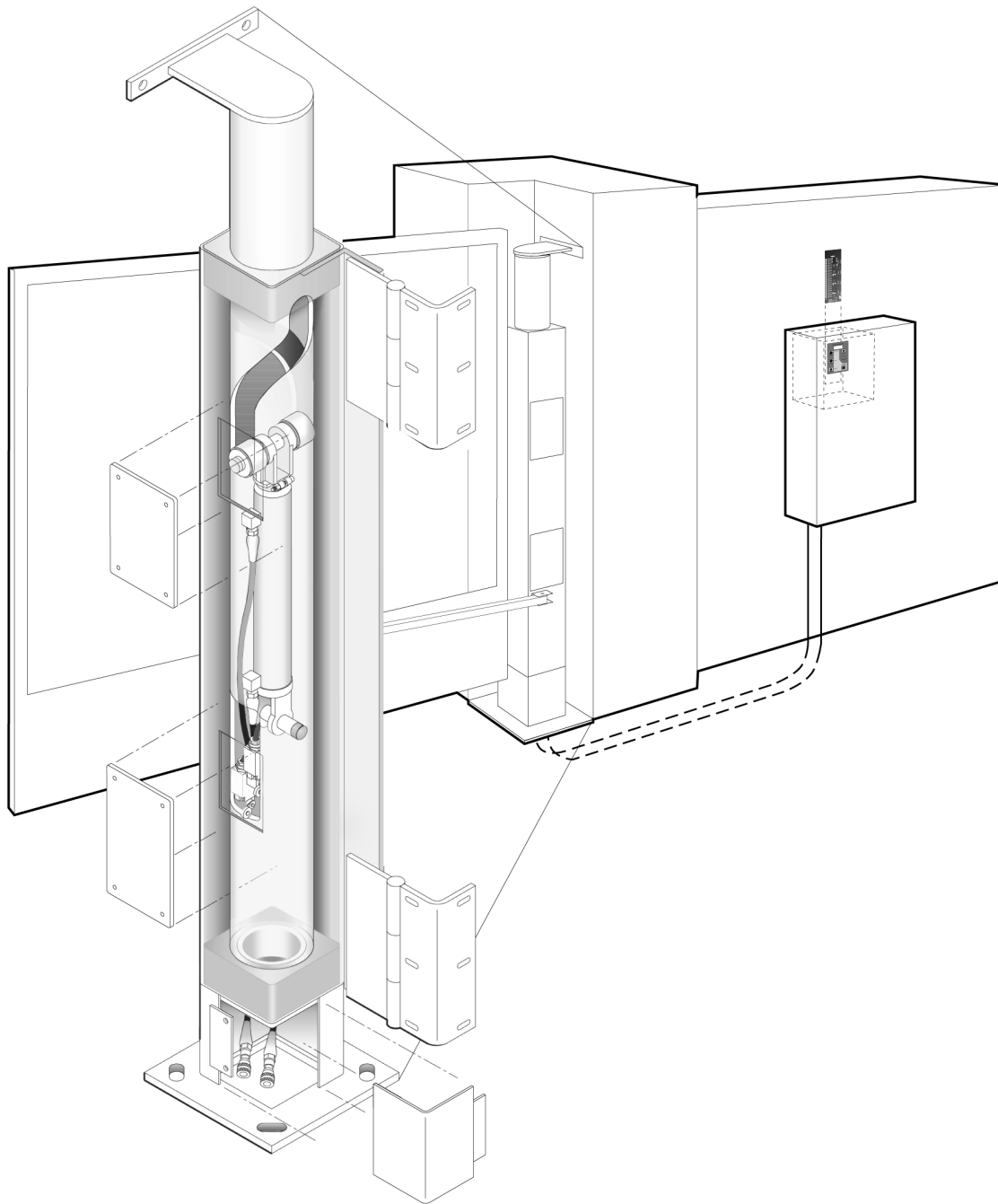

©Copyright 2001 Hy-Security Gate Inc.

All rights reserved. No part of this manual may be reproduced by any means: photocopier, electronic or mechanical, without the express written permission of Hy-Security Gate Inc. Additionally, Hy-Security Inc. makes no representations or warranty with respect to this manual. We also reserve the right to make changes in the products described without notice and without any obligation to notify any persons of any such revision or change.

## Table of Contents

Introduction.....	v
Warranty Registration .....	vi
Available Models and Features .....	1-2
<b>I. Safe Gate Design</b>	
Important Information .....	3
Install an Automatic Operator only When: .....	4
Important Information for Gate System Owners & Users .....	5
<b>I. Installation</b>	
Scope and Planning of Installation .....	6-8
Technical Drawings.....	9-11
Inside the HRG Swing Operator .....	12
Installation Preparations and Installation.....	13-18
Adjustment of Flow Regulating Valve .....	18
Manual Operation Hand Pump .....	19
<b>II. Smart Touch Set up</b>	
Basics of Using the Smart Touch Controller .....	20
Installation Configuration for Smart Touch Controller .....	21
Wiring Control Inputs to the Smart Touch Controller .....	22- 23
Connecting a Master/Slave Pair .....	24
Table of User and Installer Menu Functions .....	25 - 26
User Menu: Description Functions Available.....	27
Installer Menu: Description Functions Available.....	28 - 29
Correctional Facility / Interlocked Pair / User Optional Wiring.....	30
Options for User Programmable Output Relays .....	31
Clock Functions.....	32
<b>III. Entrapment Protection</b>	
Entrapment Protection Schematic .....	33
UL 325 Standard Requirements for Entrapment Protection Devices.....	34
Placement and Use of Secondary Pedestrian Entrapment Sensors.....	35
Installing Gate Reversing Edge (Contact Type) Sensor.....	36
Installing Photoelectric (Non-Contact) Sensor .....	37 - 38

## Table of Contents, continued

### IV. Detectors and Loops

Loop and Detector Installation Guide .....	39 - 40
Loop Layouts .....	41 - 42
Vehicle Detector Options .....	43
Hy-Security Hy-5A Vehicle Detector Installation .....	44
Standard 11 Pin Vehicle Detector installation.....	45
Vehicle Detector & Loop Fault Diagnostics .....	46

### V. Accessories

24 Hr / 7 Day Time Clock Option .....	47
Connecting a Radio Receiver .....	48

### VI. Troubleshooting and Maintenance

Troubleshooting .....	49 - 50
Maintenance .....	51 - 53

### VII. DC Operators

DC Systems (HRG 220 DC & HRG 222 DC)	
Important Notes about DC Powered Gates .....	54
Wiring & Control.....	55
Battery Connection Diagrams .....	56 - 57

### VIII. Appendix

Wiring Size Schedules .....	58 - 59
Parts Breakout Diagrams .....	60 - 64
Limited Warranty .....	65

# Introduction

Welcome – We would like to take this opportunity to thank you for this purchase. Hy-Security has manufactured the finest hydraulic gate operators available since the 1970s. Our commitment to quality and innovation will become evident as you become familiar with the features and performance of this expertly engineered machine. All Hy-Security operators are equipped with the Smart Touch Controller, a digital electronic brain that offers unparalleled features.

Please take a few minutes to study the contents of this instruction manual. The benefits of taking a little extra time to align the gate operator properly and to verify a fully functional installation will ensure customer satisfaction and a longer life with minimal maintenance costs.

**Installers and owners must be certain to thoroughly review and understand the Important Information regarding pedestrian entrapment protection contained within this manual. There are hazards associated with automatic gates that can be greatly reduced with proper design, installation use. When an automatic gate is first made functional, the installer must teach the owners and users how to operate this system correctly. When the installation is complete, leave this manual for the owner's use and reference.**

Please do not hesitate to give your Hy-Security distributor a call if you experience any difficulties during the installation. They are experienced and trained to assist in resolving any problems.

**For warranty registration, please fill in this information, fax or mail a copy to Hy-Security, then give this manual to the owner of the gate.**

Owner Name: \_\_\_\_\_  
Telephone number: \_\_\_\_\_

Hy-Security Distributor: \_\_\_\_\_  
Telephone number: \_\_\_\_\_

Installer name: \_\_\_\_\_  
Telephone number: \_\_\_\_\_

Serial number of operator: \_\_\_\_\_  
Date installed: \_\_\_\_\_

Model of Operator \_\_\_\_\_

**Warranty Registration**

Hy-Security Address:  
1200 W Nickerson  
Seattle, WA 98119

FAX:  
(206) 286-0614

Date: \_\_\_\_\_

## Available Models and Features

**Hy-Security** manufacturers twelve different models of hydraulic swing gate operators to suit the size, weight and desired speed of the gate panel. All of the operator models are derived from the standard HRG 220, upon which this manual is designed. Take a moment to identify the operator model you have and note there are some changes in the instructions, especially in regards to final adjustments of double swing gates. The following chart shows the differences at a glance:

<b>Single Panel</b>	<b>HRG 220A ST</b>	<b>HRG 220B ST</b>	<b>HRG 220C ST</b>
<b>Double Panel</b>	<b>HRG 222A ST</b>	<b>HRG 222B ST</b>	<b>HRG 222C ST</b>
<b>24V UPS Models</b>			
<b>Single Panel</b>	<b>HRG 220A DC ST</b>	<b>HRG 220B DC ST</b>	<b>HRG 220C DC ST</b>
<b>Double Panel</b>	<b>HRG 222A DC ST</b>	<b>HRG 222B DC ST</b>	<b>HRG 222C DC ST</b>

**Features:**

<b>Horsepower</b>	<i>(all HRG 220 models are 1 HP, all HRG 222 models are 2 HP)</i>		
<b>Time To Open/Close</b>	<b>14 sec</b>	<b>19 sec</b>	<b>30 sec</b>
<b>UL Usage Class</b>	<b>1 – 4</b>	<b>1 – 4</b>	<b>1 – 4</b>
<b>Warranty</b>	<b>5 years</b>	<b>5 years</b>	<b>5 years</b>
<b>Soft Stop</b>	<b>yes</b>	<b>yes</b>	<b>yes</b>
<b>Soft Start</b>	<b>yes</b>	<b>yes</b>	<b>yes</b>
<b>Gate Panel Ratings</b>			
<b>Weight Capacity</b>	<b>1000 lbs</b>	<b>1600 lbs</b>	<b>3000 lbs</b>
<b>Size Capacity</b>	<b>13 ft. wide</b>	<b>16 ft. wide</b>	<b>16 ft. wide</b>

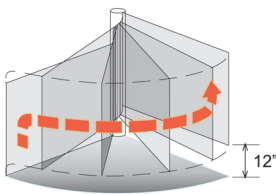

The **HRG 220** series operator is the only truly industrial grade swing gate operator on the market today. This tough operator is ideally suited to dependable operation of massive iron or steel gates. Its 3000-lb capacity provides plenty of power, and the *Lift and Swing* feature eliminates normal obstacles such as heavy snowfall and inclined or irregular roadways. The operator's mechanism is wholly enclosed inside the post and uses no other devices to push or pull on the gate panel. It's unique closing action self actuates a locking pin at the end of the gate for unparalleled security.

- Quarter turn rotating arc of 90 ° or 100 °. No actuating arms or back space required.
- Low profile power pack and electric panel are designed to be remotely located. This allows for a clean presentation at the side of the drive.
- Twelve-inch rise in the opening cycle allows the swing gate to operate easily on slopes or rise over curbs.
- Closing action drops locking pin at end of gate into socket in driveway, allowing far better security.
- Operator post is treated with an industrial galvanized flame spray finish to provide excellent corrosion resistance.
- Heavy duty components handle gates to 16 feet wide and up to 3000 lbs of any construction.
- Rated for continuous duty, up to 200,000 cycles with no maintenance.
- All components are designed for easy removal during service.
- The hydraulic system features the latest technology, modular manifolds and individually replaceable cartridge valves.
- Fully compatible with all standard access control equipment.
- Accessories include heaters, vehicle detectors, photo eyes, gate edges
- Hand pump manual operation is standard equipment.

## Available Models and Features

### The Smart Touch Controller (Standard)

This is the brain of the all Hy-Security's automatic operators. Truly high technology, but is also very rugged to reliably serve in the harsh environments that exist in the real world. The Smart Touch Controller is also very smart and can quickly be configured by an installer or user to adapt to about any functional requirement of a specific site. All system settings are performed with the use of just four programming buttons and an LCD display. The Smart Touch Controller has no switches of any type to set. An RS232 port is for external communication is standard. The system also has a real time clock and an EEPROM to record system events. The log of events can be downloaded from the RS232 port with a PC computer or a PDA with the Palm OS. Our optional vehicle detector modules set a new industry standard by communicating a host of valuable performance data to the microprocessor in the Smart Touch Controller via a serial data stream, allowing user-friendly diagnostics.

### DC 24-Volt UPS Operators (Optional Version)

These gate operators function from 24 Volts DC all of the time to achieve a true UPS system. Our **Uninterruptible Power Supply** is the most certain way to know that your gate will work when the AC power fails. This system features fully sealed maintenance free batteries in a separate insulated and ventilated enclosure.

### Pedestrian Entrapment Protection

Read and understand all the Important Information, the Entrapment Protection Schematic and the UL requirements on page 34 before beginning the installation. Be absolutely certain that the required type and quantity of Entrapment Protection devices have been supplied and that you understand how to install them correctly. Contact a distributor or the factory if there are any questions about Entrapment Protection.

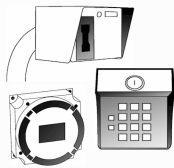

**Basic Access Control**  
 Radio Transmitter  
 Long Distance Control  
 Pushbutton Control Station  
 Programmable Time Clock  
 Card Reader

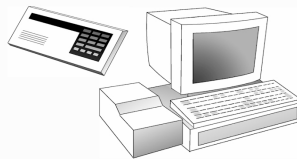

**Advanced Access Control**  
 Access Control Interface  
 Card Reader  
 Keypad  
 Telephone Entry  
 Input/Output  
 Computer Interface  
 RS232/485



**Information**  
 Signs  
 Labels  
 Warnings

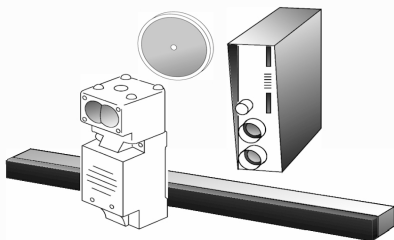

**Obstruction Sensing Devices**  
 Inherent Sensing Device  
 Gate Edges  
 Photo Eyes  
 Vehicle Detectors

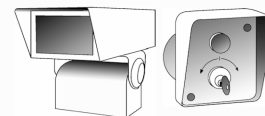

**Security**  
 Key Locks  
 Closed Circuit  
 Television  
 Gate Position Indicator  
 Interlock/Sally Port  
 Gate Status Indicator

## READ THIS FIRST!

### Important Information – Review Before Installation

Automatic gate operators provide convenience and security to users. However, because these machines can produce high levels of force it is important that all gate operator system designers, installers and end users be aware of the potential hazards associated with improperly designed, installed or maintained systems. Keep in mind that the gate operator is only one component of the total gate operating system. It is the joint responsibility of the specifier, designer, purchaser, installer and end user to verify that the total system is appropriately configured for its intended use. All parties should be informed that entrapment in a moving gate could cause serious injury or death.

#### Common Industry Symbols



**Attention  
-Take Note-**



**-Danger-  
Keep Away**

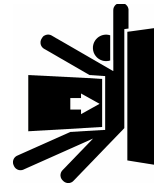

**Entrapment  
Zone**



**Possible  
Pinch Point**

#### Important Instructions for Gate System Designers & Installers:

**WARNING:** To reduce the risk of serious injury or death, read and follow all instructions in the gate operator handbook and on the warning labels.

#### Install an Automatic Gate Operator only When:

- ❑ The entry is configured for vehicular use only. Pedestrians must be directed to a separate walk-through entrance.
- ❑ The Warning signs that have been supplied with this operator must be installed, in manner clearly visible, in the area of both sides of the gate.
- ❑ All exposed pinch points, are guarded. To reduce the risk of entrapment, the gate must also be installed so that enough clearance is provided between the gate and adjacent structures both when opening and closing.
- ❑ The controls that operate the gate have been mounted far enough away from the moving gate such that users cannot touch the gate while operating the controls. All easily accessible controls must have a security feature to prevent unauthorized use.



## Install An Automatic Swing Gate Operator Only When:

- ❑ The gate moves freely in both directions. Never over-tighten a clutch or pressure relief valve to compensate for a stiff moving gate.
- ❑ The operator will not swing the gate into a public access area.
- ❑ The operator will be properly electrically grounded and the intended supply voltage matches the voltage label on the operator.
- ❑ The operator controls will be located in a clear line-of-sight to the gate. Radio controls and other remote access controls must be connected only to the **Remote Open input**.
- ❑ The required external entrapment sensors will be installed. Be certain to carefully review the instructions for placement, installation and adjustment of these external entrapment sensors. External entrapment sensors must function to reverse the movement of the gate **in both the opening and closing directions**. If edge (contact) sensors are used, they are to be located on the inside and outside leading edge of the swing gate and along the bottom edge of a swing gate that is greater than 6" above the ground. If photo eyes or other non-contact sensors are used, they are to be mounted in locations most likely to guard against entrapment. A combination of contact and non-contact sensors may be used, but all must be recognized components under the UL 325 standard. See pages 32 and 33 for details on the requirements.
- ❑ If the Entrapment protection is provided by a continuous pressure actuation control, a placard must be installed next to the control station stating "WARNING" – "Moving Gate has the Potential of Inflicting Injury or Death - Do Not Start Gate Unless Path is Clear." Additionally, no other activation device shall be connected and an automatic closing device of any kind shall not be used.
- ❑ The automatic operator is labeled as appropriate for both the type and UL usage class of the gate.
  - Class I: Intended to serve single to four family residential uses
  - Class II: Multi-family use, or any application intended to serve the general public
  - Class III: Commercial applications **not** intended to serve the general public
  - Class IV: Highest security. Security personnel prevent unauthorized access

## Important Information For Gate System Owners & Users

**WARNING: To reduce the risk of serious injury or death, read and follow all instructions in the gate operator handbook and on the warning labels.**

### **Save These Important Owner and User Instructions:**

(Installers – be certain to instruct the owners and users about the following items)

- ❑ Automatic gates are for vehicular use only! Provide walkways and signs to direct pedestrians to a separate walk-through entrance. Because an automatic gate can start at any time without warning, always keep people away from the area of the gate.
- ❑ The Warning signs that have been supplied with this operator must remain installed, in a manner clearly visible, in the area of both sides of the gate.
- ❑ Never allow children to use or play with controls that operate the gate. Keep all remote controls, especially radio transmitters, away from children.
- ❑ Teach all users how to turn off the electric power and how to release and move the gate manually. Use the manual release only when the gate is not moving.
- ❑ Test the function of the gate operator monthly. The gate **MUST** reverse its direction of travel upon contact with a rigid object, and/or stop upon sensing a 2<sup>nd</sup> sequential activation prior to reaching a full travel limit. Also test for the normal function of any non-contact sensors. If the gate system employs the use of a transmitting edge sensor, be especially certain to test and replace its battery on a routine basis.
- ❑ **KEEP AUTOMATIC GATES PROPERLY MAINTAINED.** Have a professional gate installer perform routine tests of the entrapment protection sensors, such as photo eyes and gate edges. Also, make all necessary repairs to the gate hardware to keep the gate running smoothly. Failure to adjust and test a gate operator properly can increase the risk of injury or death.
- ❑ In addition to appropriately placed external entrapment sensors, ask your installer to reduce the setting of the pressure relief valve to the lowest setting allowable that reliably operates the gate. This valve controls the force of the operator, and the sensitivity of the inherent reversing sensor.
- ❑ **Do not attempt to disable the Warn Before Operate buzzer, except in Class IV restricted access locations. This buzzer provides an alert that the gate is about to move.**

## Scope and Planning of Swing Gate Installations

### Putting it all together: sample plans

The type and location of sensors needed for proper swing gate operation depends primarily on whether the gate opens perpendicular to a wall (Fig. C) or opens to an open space (Fig. D)

**Fig. C A swing gate that opens parallel to a wall or building.**

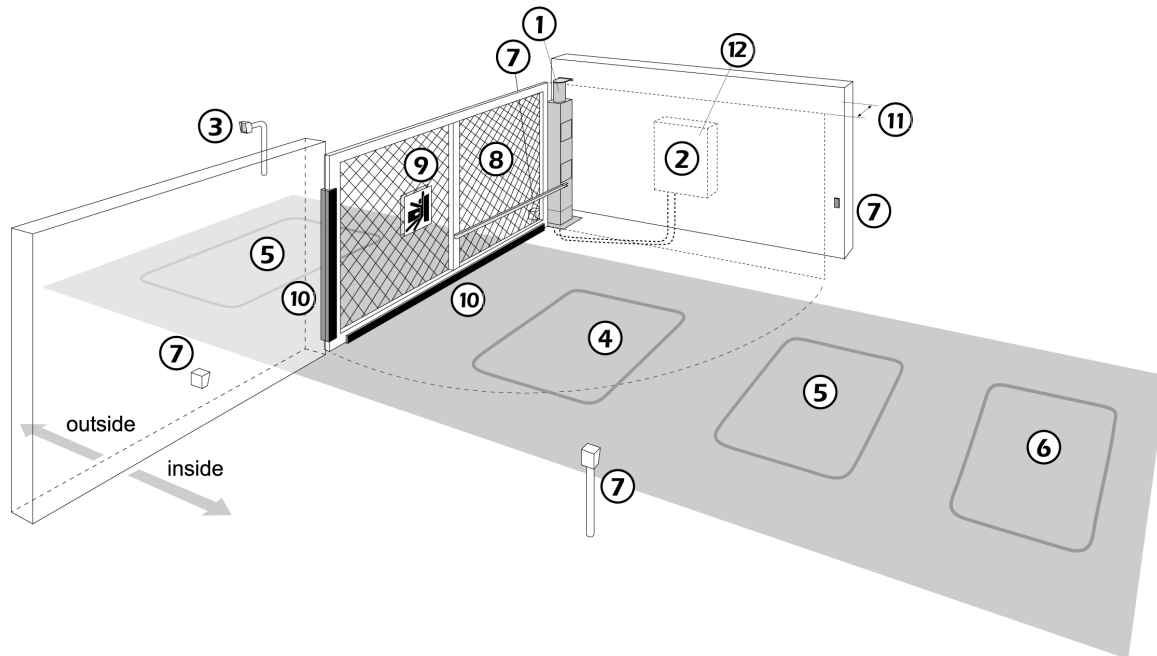

**This figure illustrates a sample plan for a gate, incorporating the elements described below.**

1. The swing gate operator automates the gate. May be ordered for left hand or right hand as shown.
2. The weather resistant NEMA 3R controller box houses the Smart Touch control and hydraulic pump.
3. An entrance control opens the gate for entry.
4. Shadow loop prevents the gate from closing on a car. This loop is active only when the gate is open.
5. Obstruction loops (Located inside and outside the swing arc of the gate)
6. Optional free exit loop
7. Photo eyes stop the gate to help prevent vehicular or personal entrapment.
8. Safety mesh on the gate panel prevents reaching through the gate panel.
9. Warning signs alert users to the danger of entrapment when using automatic gate operators.
10. Sensing edges on the bottom of the gate and inside and the outside leading edge of the gate panel send a signal to operator to stop and reverse when an obstruction is encountered.
11. The physical clearances must be configured to stop the gate panel 16 inches away from the wall to protect someone from being crushed.
12. A warning buzzer sounds an alert when an obstruction is sensed and can warn before gate motion.

## Scope and Planning of Swing Gate Installations

### Putting it all together: sample plans

Fig. D A swing gate that opens to empty space

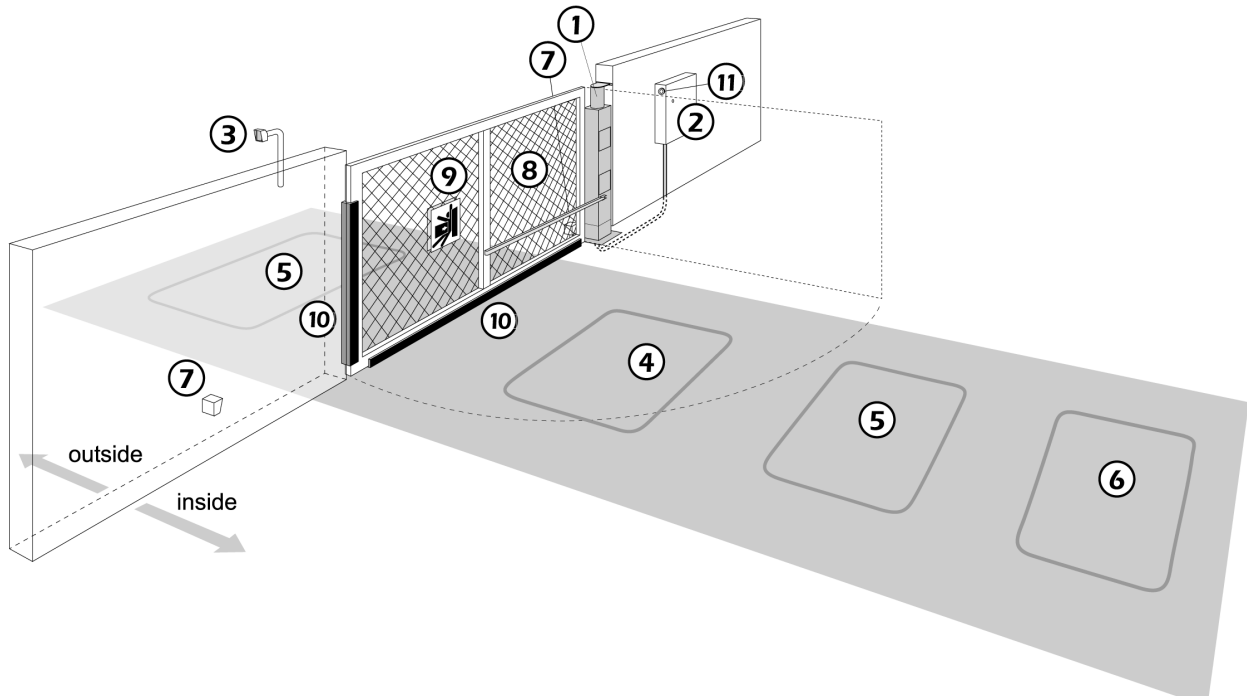

**This figure illustrates a sample plan for a gate, incorporating the elements described below.**

1. The swing gate operator automates the gate. May be ordered for left hand or right hand as shown.
2. The weather resistant NEMA 3R controller box houses the Smart Touch control and hydraulic pump.
3. An entrance control opens the gate for entry.
4. Shadow loop prevents the gate from closing on a car. This loop is active only when the gate is open.
5. Obstruction loops (Located inside and outside the swing arc of the gate)
6. Optional free exit loop
7. Photo eyes stop the gate to help prevent vehicular or personal entrapment.
8. Safety mesh on the gate panel prevents reaching through the gate panel.
9. Warning signs alert users to the danger of entrapment when using automatic gate operators.
10. Sensing edges on the bottom of the gate and inside and the outside leading edge of the gate panel send a signal to operator to stop and reverse when an obstruction is encountered.
11. A warning buzzer sounds an alert when an obstruction is sensed and can warn before gate motion.

## Tools Required for an Efficient Installation

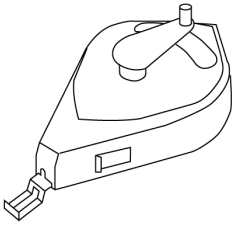

1. Chalkline or other builders string

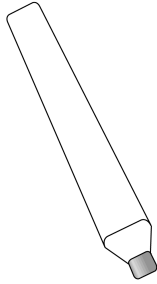

2. Carpenters pencil or crayon

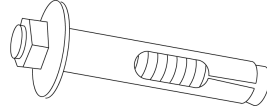

3. Concrete anchor bolts, four 5/8" – 3/4"

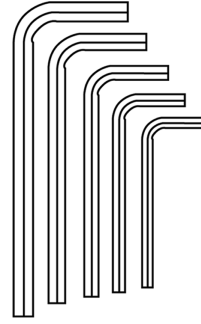

4. Allen wrench set

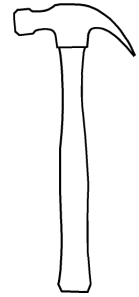

5. Hammer

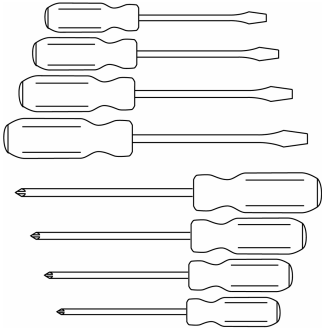

6. Screwdriver sets, Straight and Phillips

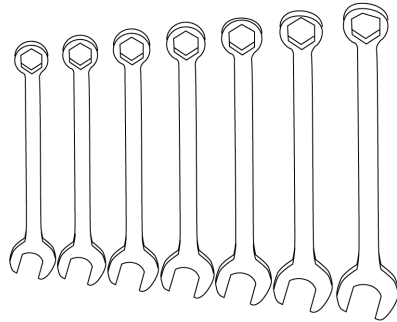

7. Wrench set, open end, 1/4" through 1"

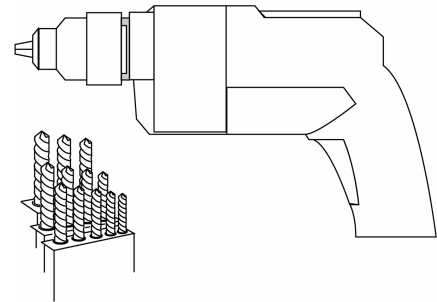

8. Electric drill and bits, 1/8" through 3/8"

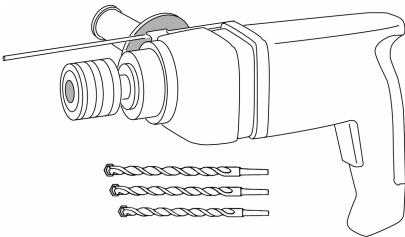

9. Roto-hammer and bits to accommodate anchor bolts

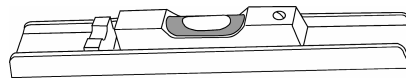

10. Level—it doesn't need to look like this one, but the installation needs to be level!

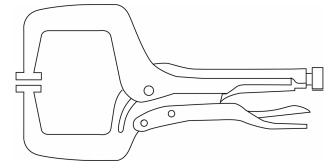

11. Two pair wide jaw vice grip pliers, or two C clamps, 4" capacity

# Swing Gate Post Details

1 SINGLE POST SHOWN. OPPOSITE POST SIMILAR MIRROR IMAGE.

2 CUSTOM HEIGHT ADDS TO THIS DIMENSION.

NOTE: ALL LATERAL FORCES MUST BE SUPPORTED BY BACKING POST/PILASTER.

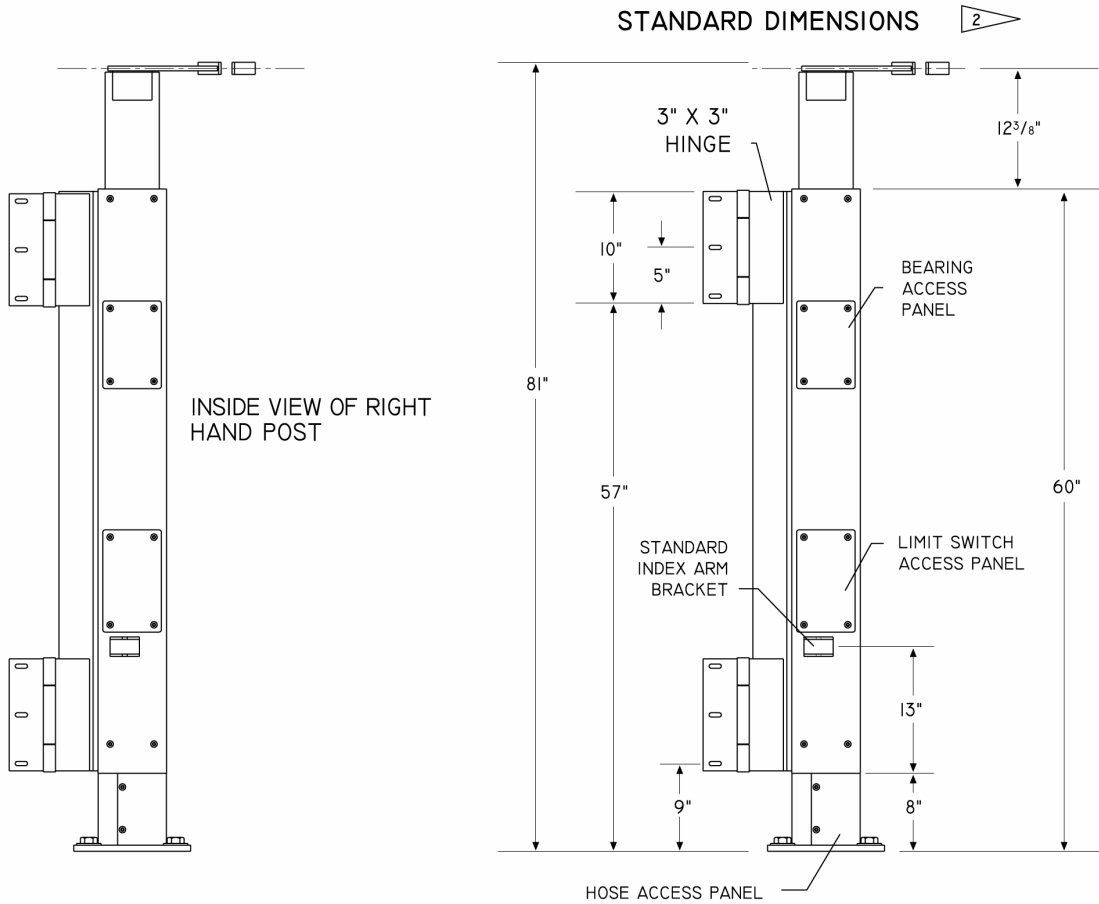

## TYPICAL TOP CAP INSTALLATIONS

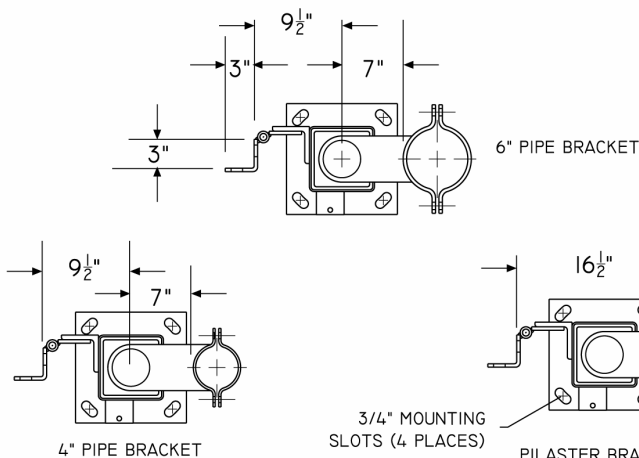

## FOOTPRINT DIMENSIONS

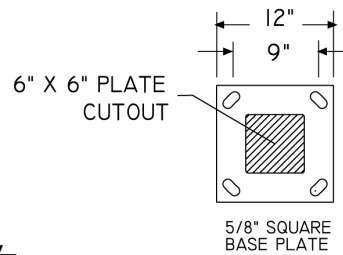

HR34

# HRG 220 - Pump Pack

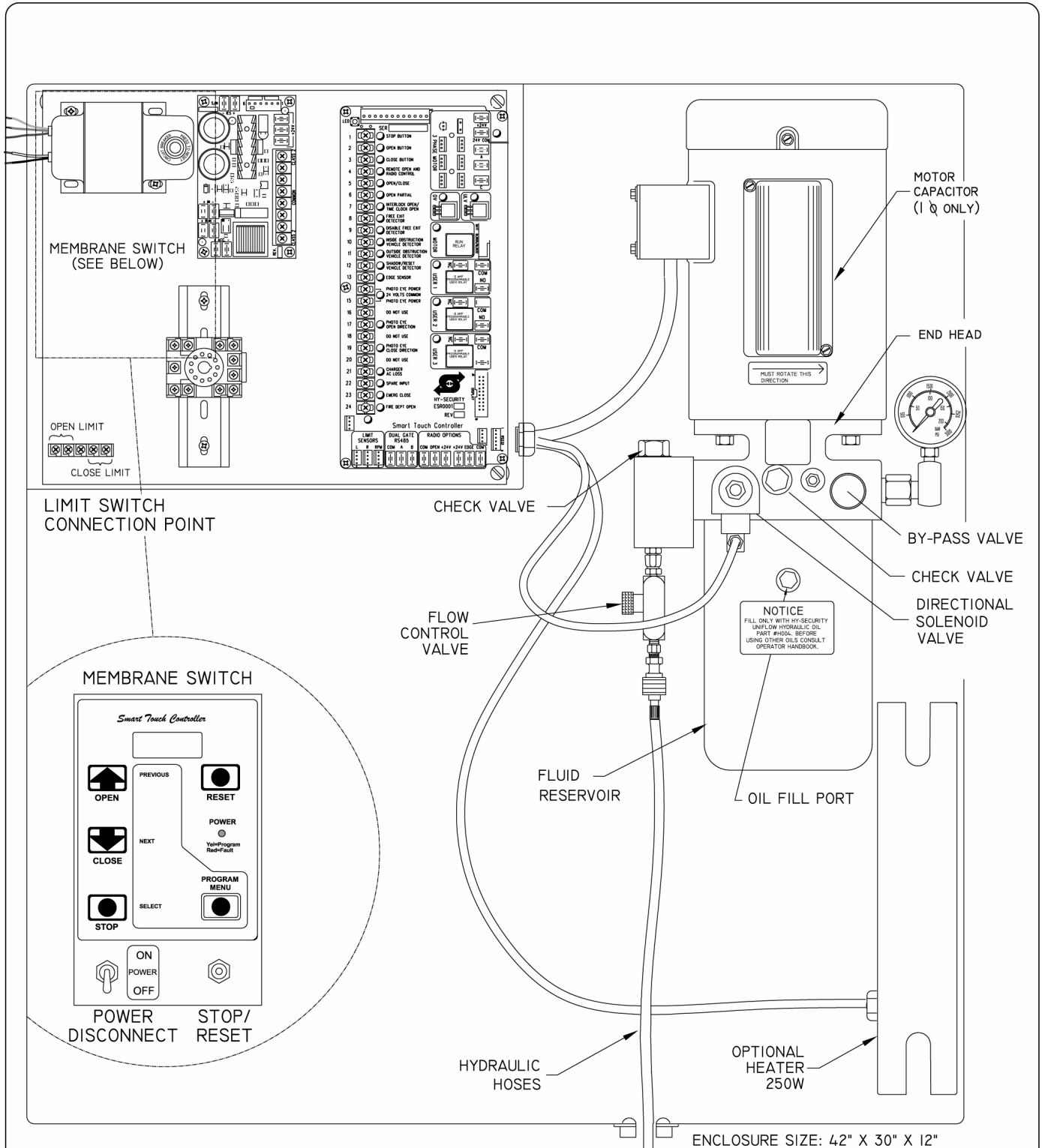

NOTE: HAND PUMPS ARE STANDARD IN ALL HRG MODELS  
SEE DRAWING HR16 FOR DETAILS

HRG 220 POWER PACKAGE (TYP) PUMP AND ELECTRICAL PANEL

HR36-3

# HRG 222 Pump Pack

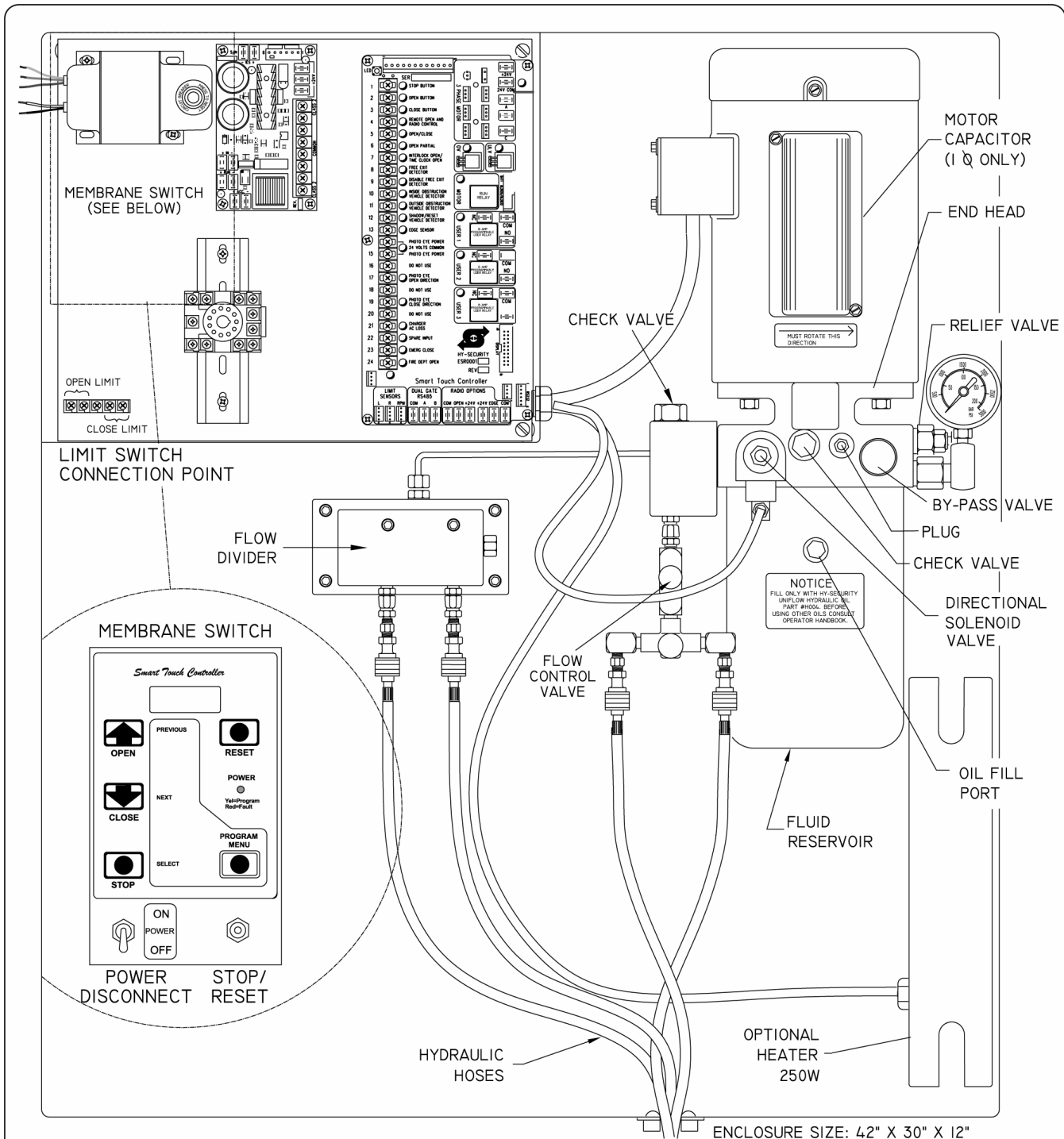

NOTE:  
 BE CERTAIN TO MATCH THE COLOR CODING ON THE QUICK DISCONNECTS,  
 THIS IS TO ASSURE A CORRECT CONNECTION.  
 NOTE: HAND PUMPS ARE STANDARD IN ALL HRG MODELS  
 SEE DRAWING HRI6 FOR DETAILS

HRG 222 POWER PACKAGE (TYP) PUMP AND ELECTRICAL PANEL

HR35-3

# How Our Hydraulic Swing Gates Work

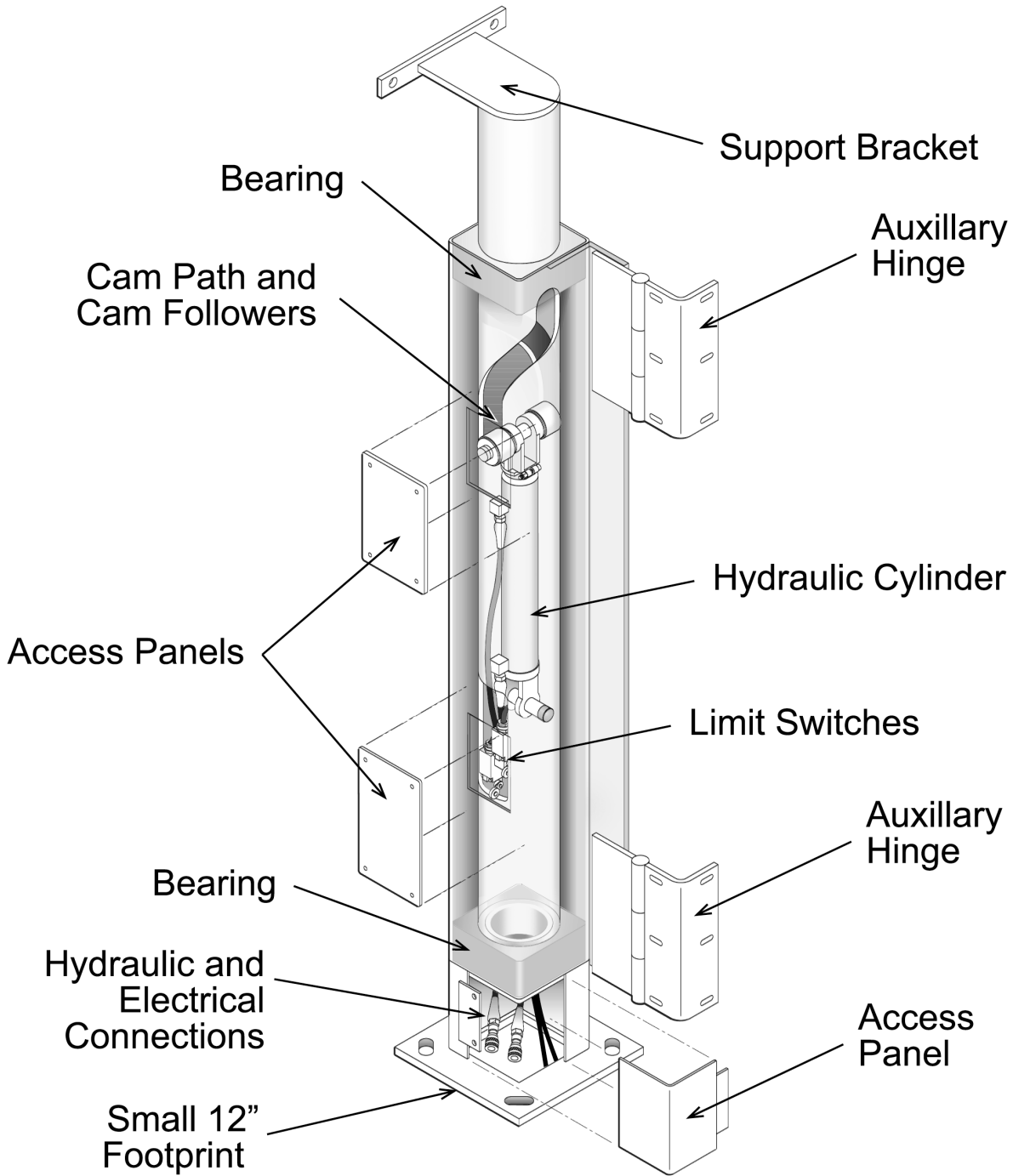

## Inside the HRG Swing Operator

## Installation Preparation Checklist

1. Read *all* of the instructions, especially the Important Information at the beginning of this manual, before you attempt installation. This section is focused upon mechanical installation. For electrical setup, skip to the section on system configuration and use of the Smart Touch Controller.

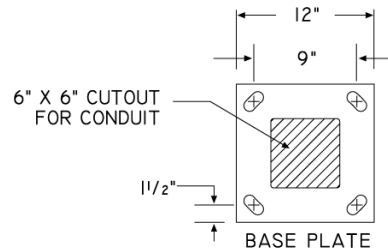

2. Check to see that the mounting slab is the right size and ready to have an operator attached. Also check that electrical conduits are correctly located to enter the operator base. Hy-Security recommends the slab reaches below the local frost line and is poured together with supporting post or pilaster.

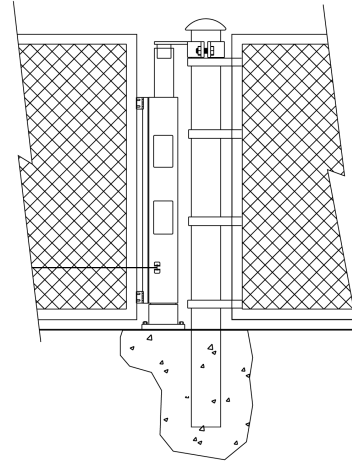

**NOTE: The backing post/column, (provided by others) must accommodate all of the "tip over" loads imposed by the gate panel.**

## Installation Process Overview

- Mount the control box and connect all conduit fittings.
- Mount the operator post.
- Install all accessories such as: vehicle sensing loops, access control devices, gate edge sensors or photo eyes.
- Pull all wires and hoses into conduits. **Note: HRG 220 comes with up to 40' of hose for the HRG 222 with up to 100' of hose, however, you must advise the factory on the accurate amount of hose desired or it will not be shipped with the operator.**
- Test the basic operator functions.
- Mount the gate panel and make fine adjustments.

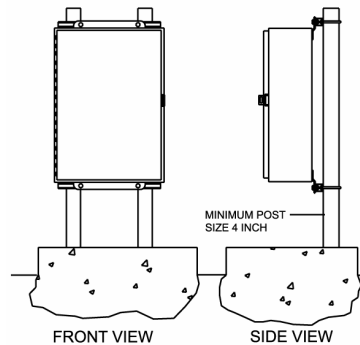

This panel must be located within 100 ft. of gate operator post (Fig. A).

TYPICAL TOP CAP INSTALLATIONS

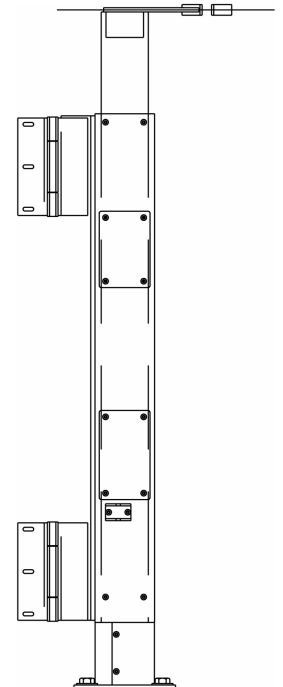
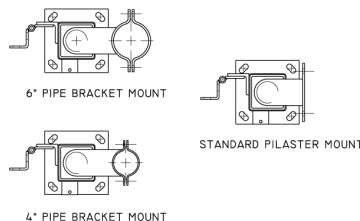

## Field Hose Measurements for HRG Operators

**Note: HRG operators are usually shipped without the hoses needed to complete the system.** Hy-Security will make these hoses in custom lengths as required, attach the quick disconnect fittings and pre-charge the hoses with hydraulic fluid. The use of pre-charged hoses is important to avoid the introduction of air into the system.

When field measuring for the necessary hose length to order, the following may be helpful:

1. There is little room in the base of the HRG operator post and limited room in the control/power panel, therefore, your field measurements must be very accurate when calculating the length of the necessary hydraulic hoses. If your dimensions are too little, you will not reach the connections, if your measurements are too long, you will have trouble finding space for the excess hose.
2. Remember that two hoses are needed for each cylinder. This means that you need four hoses when you are installing a HRG 222 (pair) operator.

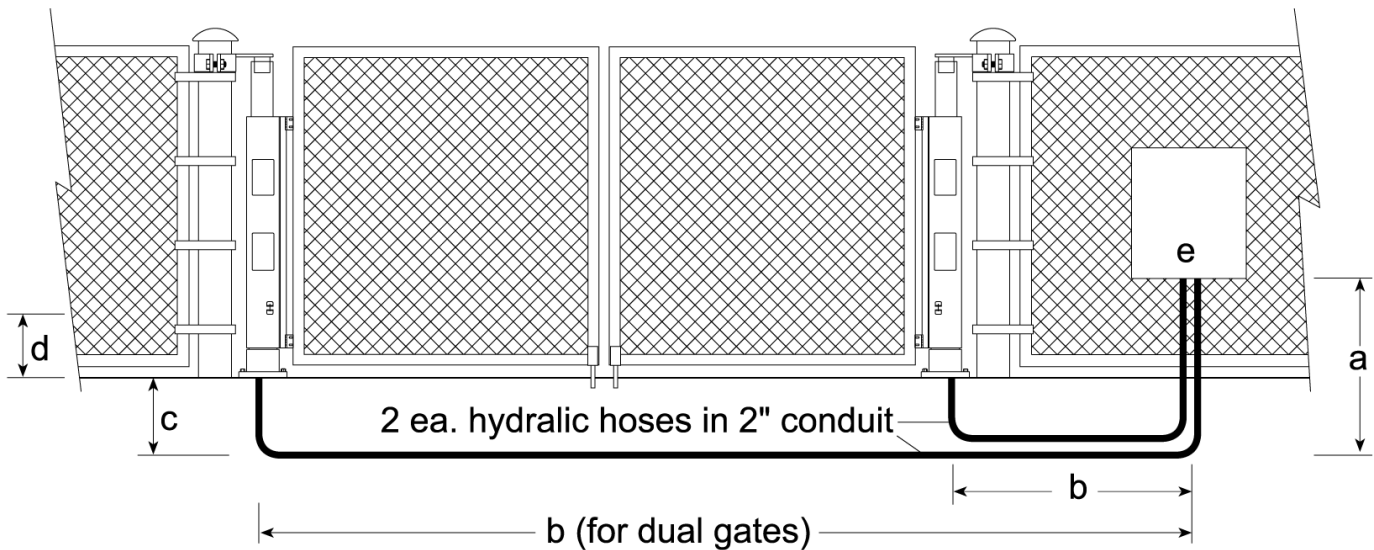

- 1) Be sure to measure accurately the following distances: (the best way is to pull a cord through the conduit, mark it, and then measure it.)

- a) The bottom of the pump/control panel to the bottom of the trench, plus 24"
- b) The total distance across the trench.
- c) The distance back up to the bottom of the operator, plus 6"

- 1) The part number for the hoses is:

1/4" hose for HRG: HSFHO 004 SW

The HRG 220 includes up to 40' total length for the two hoses required.

The HRG 222 includes up to 100' total length for the four hoses required.

**For assistance call your distributor.**

## Detailed Installation Instructions for HRG Swing Gate Operator

### 1) Mount control box and connect all conduit fittings.

- a) Mount controller box within 100' of the gate operator, preferably within 20'. If installing the DC version of the operator, mount the battery power supply very near the controller enclosure because of the high current demand by the DC motor – See the Two Part operator section.
- b) Attach all electrical conduits as required, note the diagram below and see step number 3.

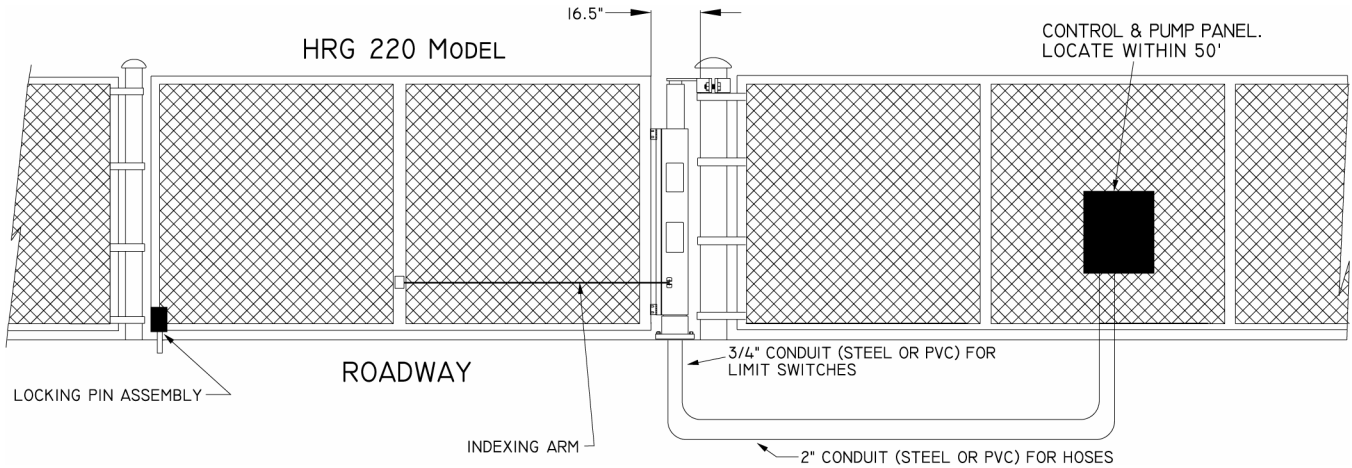

### 2) Mount operator post

- a) Using 5/8" – 3/4" anchor bolts, mount the 12" square operator base with 1" clearance between the base and the backing post or wall. The gap between the operator post and the backing post will be 3 1/2". It is important that the finished installation be plumb and true. Use shims if necessary to level the operator base.
- b) Attach the top of the operator to the backing post or supporting wall, using the bracket provided. The attaching bracket "sleeves" inside the top of the operator post. **Note! The backing post/column, (provided by others) must accommodate all of the "tip over" loads imposed by the gate panel.**

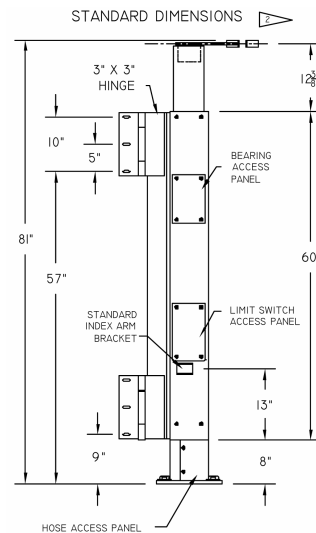

### TYPICAL TOP CAP INSTALLATIONS

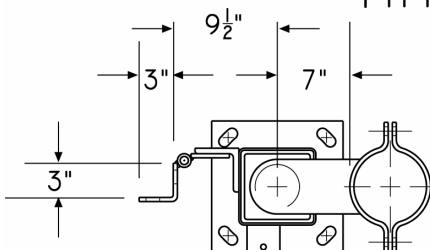

6" PIPE BRACKET MOUNT

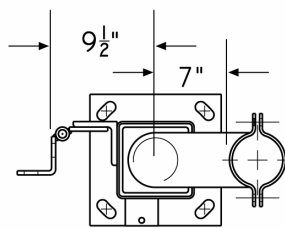

4" PIPE BRACKET MOUNT

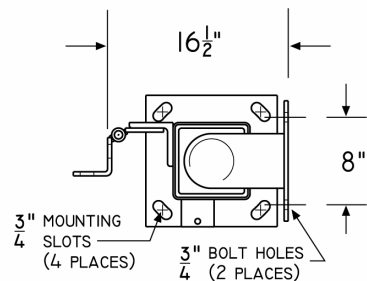

STANDARD PILASTER MOUNT

**3) Typical conduits required at the control panel**

- a) High voltage wires: (120, 208, 240) single phase or (208, 240, 480) three phase  
Note: 120 VAC not available on 2HP models
- b) 2" conduit to the hydraulic post(s) for hoses.
- c) 3/4" conduit to the post(s) for limit switches.
- d) Access control wires (Keypads, telephone entry systems or any access control devices)
- e) Loop wires for vehicle detectors
- f) Other accessories such as warning lights etc.

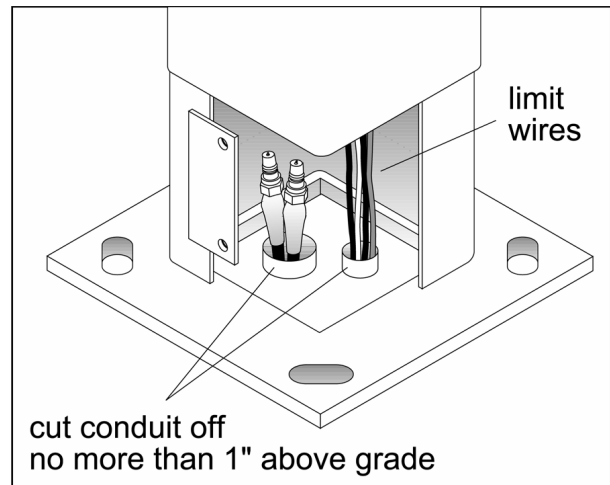

**4) Mount or install all control wiring such as loops, access control, and entrapment protection sensors. See detailed instructions**

**5) Pull and connect all wires and hydraulic hoses**

- a) Pull four wires, 18 gage minimum, for the limit switches from control panel to junction area in the base of the operator post(s). This may be either by underground conduit or by a seal-tight conduit into the side of the base.
- b) Remove the lower cover (at 2' height) on the post(s) to expose the limit switches and connect the limit switch wires. The open limit switch is on the left and lower than the close limit. Connect these wires to the control box at the five pole terminal strip marked open limit and close limit.
- c) HRG operators normally do not ship with the hydraulic hoses included, until the exact length is specified by the installer. See page 14 and verify the correct length before ordering.
- d) For protection, tape the ends and pull the hoses through the 2" conduit from each post to the controller box. Connect the hoses to the couplings, being certain to match the color coded ends. Also be certain that the connectors are firmly snapped together.
- e) Remove the blue plastic shipping plug on the pump and replace it with the vent cap that is provided.
- f) Connect the electrical power wiring to the loose wires from the On/Off switch and a grounding wire to the lower left corner of the electrical panel. Be certain to the labeled voltage and phase of the operator matches the available supply. Also be certain to oversize the branch circuit wires to allow for voltage drop, especially for single-phase machines. See the wire size schedules in the appendix. Machines to operate on high voltages (above 120 VAC) do not need a neutral wire.
- g) Verify that the primary tap of the control transformer is connected to match the supplied voltage. It is especially important to distinguish between 208 and 230 volt supplies. The various voltage taps are identified by a label on the transformer.

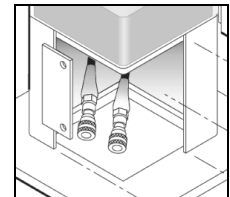

Access panel at operator base

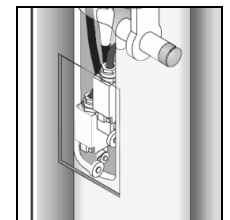

limit switches

**6) Test and Adjust the Operator (See Smart Touch Setup First)**

- a) Test basic functions of the operator first, before connecting any external control wiring. If your operator is equipped with vehicle detectors, be certain that they are connected to a loop or unplugged so that they do not cause interference with the function of the machine. If the motor turns, but nothing moves, reverse two poles of a three phase power source. Also check that the by-pass valve is closed. Push in the round black knob that is located on the right side of the pump manifold. Also be certain that the hose quick connectors are firmly engaged.
- b) After testing the basic functions, add accessories and external control wiring. Fully test the operator functions again.

## Mounting the Gate Panel, Index Arm, and Lock Pin Assembly

- 1) Mount the gate panel with at least six 3/8" bolts (not provided) through both sides of the 11" hinge. Be certain to provide the correct clearance between the gate and the road surface. Allow 3" clearance at the far end of the gate panel. See drawings for gate panel clearance dimensions.
- 2) Clamp the index arm mounting bracket near the bottom of a vertical member of the gate. The best attachment point is at the one-third to one-half of the gate length from the gate hinge.

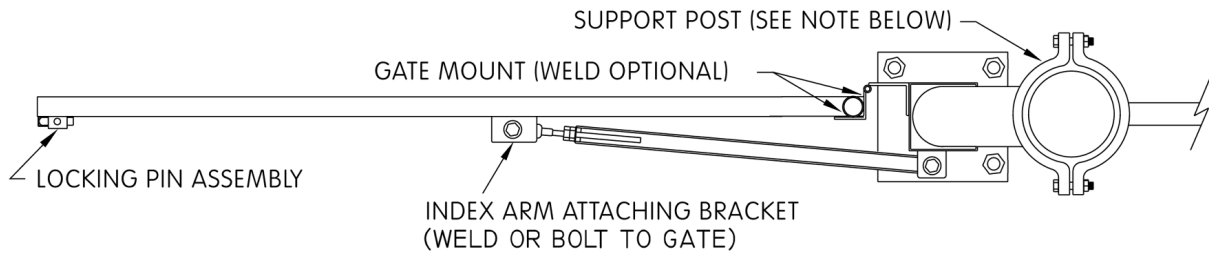

PLAN VIEW, GATE PANEL, OPERATOR POST, INDEX ARM AND LOCKING PIN

- 3) Cut the index arm to the correct length and drill a 1/2" hole through the 2 x 2 tube where it will attach to the swing gate post. Connect the threaded rod end of the Index arm to the mounting bracket on the gate panel and bolt the cut end of the index arm between the tabs on the operator post assembly.
- 4) Mount the locking pin mechanism on the lower corner of the free end of the gate panel in such a position that the pin penetrates 2" into a lock receptacle when the gate is fully closed.

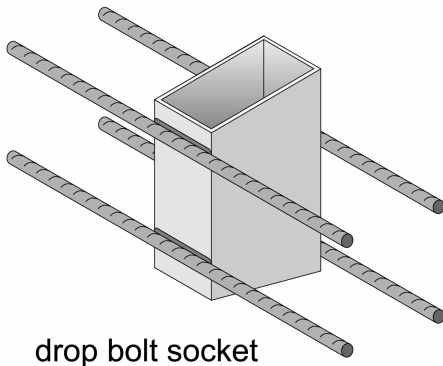

- 5) Bury the receptacle tube in the roadway to act as a socket for the locking pin. If the assembly provided by Hy-Security is not used, the tube should have an angular cut on the tip and project about two inches above the grade to act as a "catch" for the locking pin. Use a 3-1/2" x 1-1/2" tube of appropriate length for this purpose. Use blacktop or grout to create a mound around the exposed tube, so passing vehicles encounter a smooth bump.

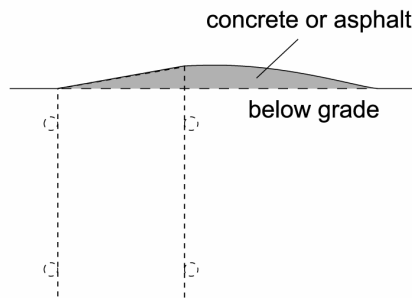
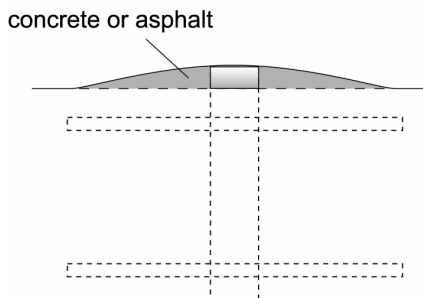

If a catch is not necessary, the drop bolt socket may be cut to create a level and flush installation.

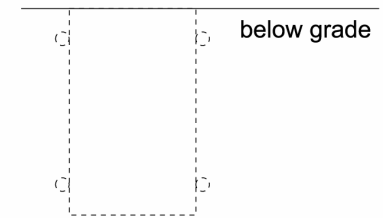

- 6) Adjust the threaded end of the index arm to place the free end of the gate in an exact position for the locking pin to strike and slide down into the receptacle as the gate closes. The most reliable index arm adjustment will allow the gate to swing slightly past center so that the lock pin strikes the back of the receptacle. Tighten all parts of the index arm assembly firmly for trouble free operation.

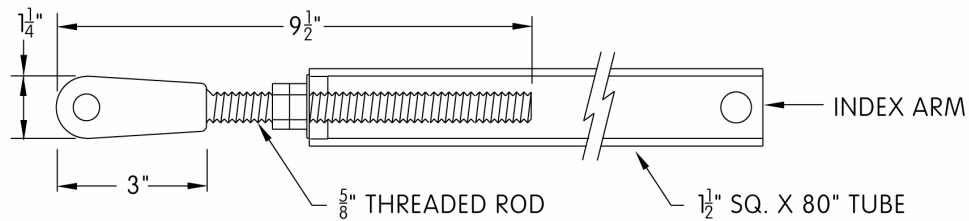

### Lock Pin Assembly

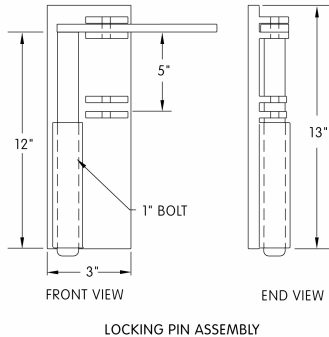

**NOTICE:** If the locking pin mechanism is not used, security of this system is adversely affected and the operator drive shaft may be exposed to high stresses by wind loading or vandals. If the lock pin receptacle is not built or installed to create a strike stop for the gate, the lock pin may not always align with the receptacle.

### Adjustment of the Flow Control Regulating Valve

HRG Swing gate operators employ the use of a flow control valve to control the closing speed of the gate. The flow control valve is the small rectangular brass device with the knurled adjusting knob, located just above the red quick-disconnect fitting for the hydraulic hose.

To adjust the close flow control valve correctly, pre-set the valve set such that only two of the color bands (red & blue) below the adjusting knob are exposed. Run the gate in the close direction and turn the flow control valve clockwise until you have achieved a good control of the gate in the closed direction. The most crucial part of the closing of the swing gate is when the lock pin strikes its receptacle. The flow control valve adjustment is most helpful for maintaining control at this point of operation. (Other important adjustments are necessary for correct locking. See separate instructions on "Adjustment of Indexing Arm")

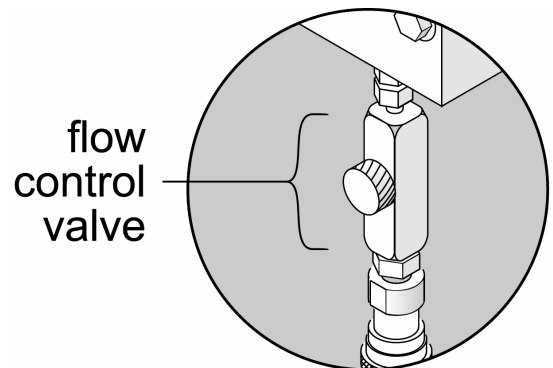

**Caution:** Over-tightening of the flow control valve will cause the operator to draw more motor horsepower than necessary or desirable, and cause additional stress on the hydraulic power unit.

Be sure to tighten the set screw on the adjusting knob to lock your adjustment.

## Instructions for Hand Pump or Manual Operation

### HAND PUMP OPERATION

**TO CLOSE THE GATE:**  
SIMPLY OPERATE THE HAND PUMP,  
NO OTHER ACTION IS REQUIRED.

**TO OPEN THE GATE:**  
PULL AND TWIST THE KNURLED  
KNOB ON THE DIRECTIONAL SOLENOID  
VALVE THEN OPERATE THE HAND PUMP.

**NOTE:**  
BE CERTAIN TO TWIST AND RELEASE  
THE KNURLED KNOB ON THE  
DIRECTIONAL VALVE TO THE RETURN  
TO NORMAL OPERATION.

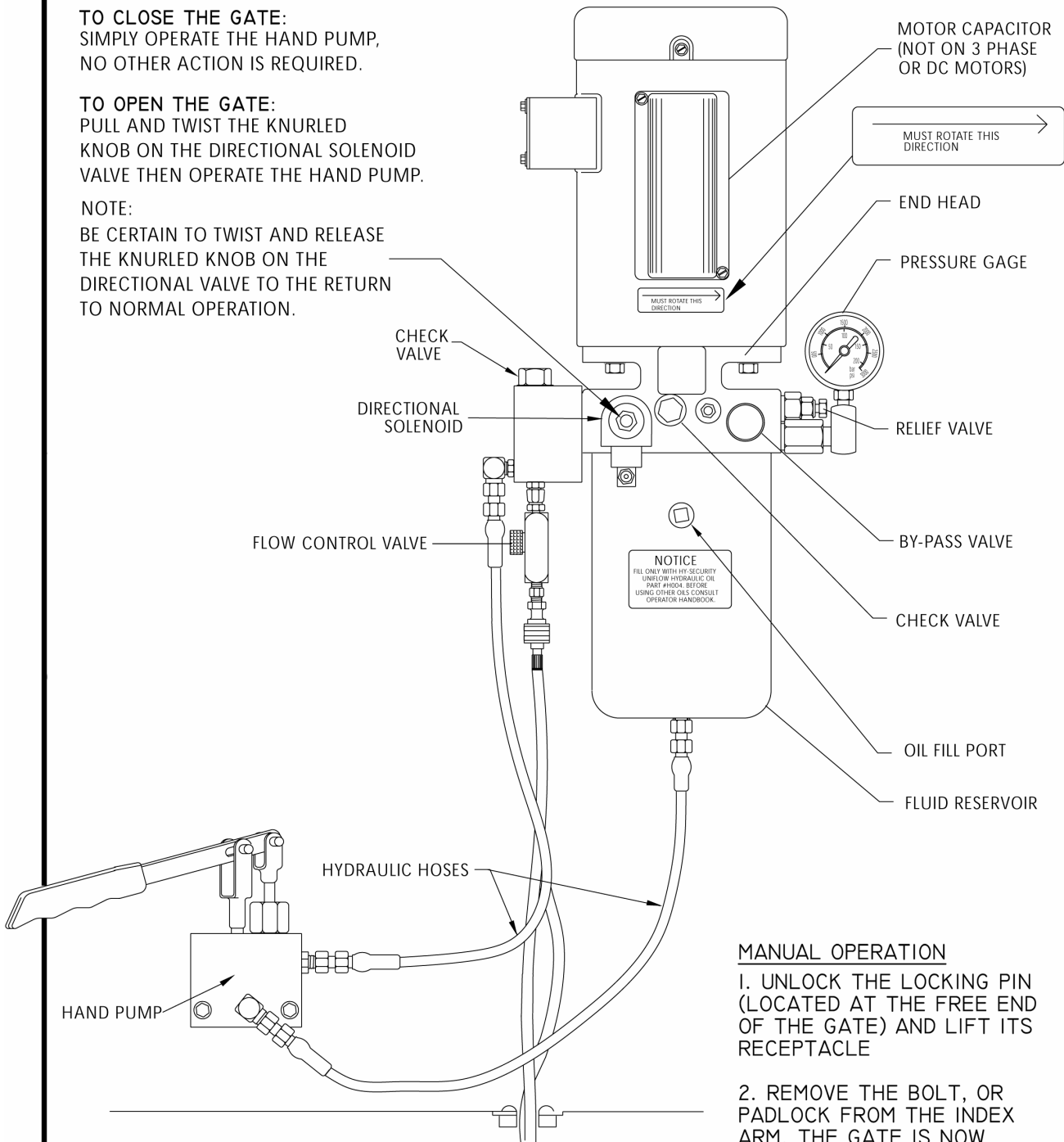

### MANUAL OPERATION

1. UNLOCK THE LOCKING PIN (LOCATED AT THE FREE END OF THE GATE) AND LIFT ITS RECEPTACLE
2. REMOVE THE BOLT, OR PADLOCK FROM THE INDEX ARM. THE GATE IS NOW FREE TO SWING ON ITS AUXILIARY HINGES

seattle_washington	TITLE	DRAWN	DATE	THIRD ANGLE PROJECTION	REV
	HRG HAND PUMP & MANUAL OPERATION	D.B.	05/08/0	⊕	A
		CHECKED	DATE	ERN NUMBER	
	APPROVED	DATE	DRAWING NUMBER: HR16		SHT OF 1 1

## Basics of Using the Smart Touch Controller System

Read this page if you are unfamiliar with using the Smart Touch Controller.

You must learn to navigate and change menu settings within the Smart Touch Controller before an installation can be completed or any control settings or function changes can be made.

**Until a new operator has been configured, the controls are not functional and the display is locked in the menu mode until the User Class 1-4, has been selected. See the next page for instructions on how make this setting.**

1. There are five buttons on the membrane switch pad that provide control of everything. The Open, Close and Stop buttons serve as a three-button control station, but in the Menu Mode, they become Previous, Next and Select buttons. The Program Menu button is used to both enter and exit the Menu Mode. The Reset button clears all Errors or Faults that may occur and returns the control to its normal functioning state.
2. When in a Menu Mode, changes to be made to a Menu setting are accomplished by pressing the Previous, Next and Select buttons in the following sequence:
  - a. Press the Next button to move forward through the list of menu items that are available, as shown on pages 25 & 26, or press the Previous button to move back to an item that you recently passed.
  - b. Press the Select button if you wish to make a setting change to a menu item. The menu item will flash to indicate that its setting is ready to be changed.
  - c. Press Next to move forward or Previous to go back to an earlier setting choice.
  - d. When you have located the setting that you want to use, press the Select button and the program will accept the change and stop blinking.
  - e. The Program Menu button does not allow an exit to Run Mode while a selection is still blinking. Press the Select button to stop the blinking, then you may exit to Run Mode.
  - f. Pressing the Next or Previous buttons when the menu item is not blinking will move to the next or previous menu item.
  - g. When done, press Program Menu to exit to the Run Mode.

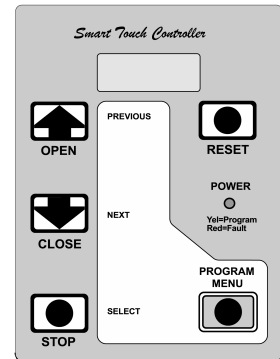

- a. Press the Next button to move forward through the list of menu items that are available, as shown on pages 25 & 26, or press the Previous button to move back to an item that you recently passed.
  - b. Press the Select button if you wish to make a setting change to a menu item. The menu item will flash to indicate that its setting is ready to be changed.
  - c. Press Next to move forward or Previous to go back to an earlier setting choice.
  - d. When you have located the setting that you want to use, press the Select button and the program will accept the change and stop blinking.
  - e. The Program Menu button does not allow an exit to Run Mode while a selection is still blinking. Press the Select button to stop the blinking, then you may exit to Run Mode.
  - f. Pressing the Next or Previous buttons when the menu item is not blinking will move to the next or previous menu item.
  - g. When done, press Program Menu to exit to the Run Mode.
3. Once configured, the operator will be in the Run Mode. From the Run Mode, to gain access the User Menu or the Installer Menu, follow these steps:
    - a. Note that the Program Menu button will not function unless the gate is at rest and no open or close inputs are active. Verify system status by pressing the LED button to disclose any active inputs. There also must not be any Alerts, Faults or Errors. Press the Reset button to clear the system if necessary.

- b. Press the Program Menu button and watch the LCD scroll the system data, or press the Program Menu key a 2<sup>nd</sup> time to skip the scroll. The scrolled data displays the information in the table on page 25.
  - c. The LCD display scroll will stop at the menu item for the auto close timer setting [Ct \_\_\_]. This is the first item in the User Menu.
  - d. To access the more detailed Installer Menu, the system must first be in the User Menu, and then simultaneously press the Reset button and the Open button. The LCD will change to display the UL usage class menu item [uC \_\_\_] This is the first item in the Installer Menu.
4. Pressing the Program Menu button when the User or Installer Menu is not blinking will return the system to the Run Mode.

## Installation Configuration for Smart Touch Controller

### Basic Configuration and Setting of the Usage Class

1. The hydraulic hoses must be connected to the quick couplers by matching the color coded ends to configure the correct directional control of the gate. If the hoses are connected incorrectly, the gate will run backwards (close when open button is activated) and this may trigger an error [Err 1] on the LCD display. (The Reset button must be pushed if this happens).
2. Turn on the power switch and observe that the LCD will first show the software version, and then stop at a steady display within two seconds. If the display reads [uC 0] go to step 3. If the operator has previously been configured, the Installer Menu must be accessed in order to reach the system configuration menu items: see step 3d at the top of this page.
3. When turning on the power for a new machine, the LCD display directly enters the Installer Menu at the [uC \_\_\_] menu item, which is for selecting the user class as defined by UL. Select [uC 1] - [uC 2] - [uC 3] or [uC 4] depending upon the use application.
4. Once the usage class is set, you should exit the Installer Menu, by pressing the Program Menu button. The LCD display jumps to the close timer [Ct\_\_\_] setting in the User menu, which may now be set. Either press the Program Menu button again to exit to normal run mode or set the close timer by the same programming sequence described at the previous page.
5. **Note that the Installer menu cannot be exited by any means until the selection for the UL usage class [uC \_\_\_] has been entered.**

Test for normal function of the gate operator by running it both open and closed from the pushbuttons on the membrane switch pad. It is best to verify normal function before the gate panel has been mounted.

## Wiring Control Inputs to the Smart Touch Controller

1. Test the basic open and close operator function before wiring the external control inputs. This makes it easier to troubleshoot if an unexpected function issue arises.
2. Each input has an LED to indicate when that input is active. To disclose the input status, the LED tact button must be pushed. This button is in corner near the Stop input.
3. All the control device inputs listed below are shown as a single input because the other wire is connected the Common Terminal Buss on the Power Supply board. The Emergency Close and Fire Dept. Open inputs are an exception and require a +24 Volt input in order to be activated. The +24 is available at the spade terminals next to the Common Buss.

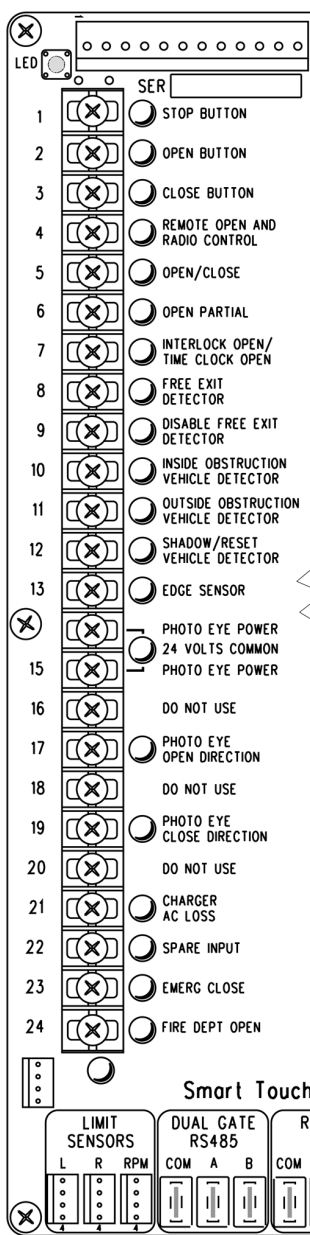

### Smart Touch Controller Inputs

- 1) **\* Stop Push button** (N.C. input, jumper to Common if unused)
- 2) **\* Open Push Button** (not for radio or remote access controls)
- 3) **\* Close Push button** (not for radio or remote access controls)
- 4) **Remote Open & Radio Control** (For radio / remote open device - menu opt. to also close)
- 5) **Open/Close button** (pushbutton or radio controls)
- 6) **Partial Open** (this input disabled on swing gates)
- 7) **Open interlock input or Time clock Open** (menu configurable)
- 8) **Free Exit vehicle detector**
- 9) **Disable Free Exit vehicle detector**
- 10) **Inside Obstruction vehicle detector** (Inside reversing loop)
- 11) **Outside Obstruction vehicle detector** (Outside reversing loop)
- 12) **Shadow vehicle detector** (This is the loop under the arc of the gate)
- 13) **Edge Sensor** (one input works for both directions of travel)
- 14-15) **Photo eye Common Power** (supply for PE power & PE Com)
- 17) **Photo eye Open direction** (beam spans the area where gate opens)
- 19) **Photo eye Close direction** (beam spans across the road)
- 21) **Charger AC power loss** (only used in battery type operators)
- 22) **Spare Input** (unused – may have function in custom applications)
- 23) **\*Emergency Close** (must menu enable and input +24 Volts to trigger) Overrides photo eyes, gate edge & vehicle detectors.
- 24) **\*Fire Dept. Open** (must menu enable and input +24 Volts to trigger) Overrides photo eyes & gate edge.



#### Attention

\* Do not connect an external control to terminals #1, 2 or 3, unless the controls are located such that there is a clear view of the entire gate area. For controls not within sight, use input terminals #4, 5, 6 or 7.

\*The Emergency Close and Fire Dept. Open inputs are to be used only if access to these controls are guarded in sufficient manner such that there is always supervision when activated.



## Connecting a Master / Slave Pair

The HRG 222 is automatically programmed to operate as a master slave set. If you are installing two HRG 220's to operate as a Master/Slave pair, the process is very simple. There is no need to order a special model or any adapters. The area of the board marked Dual Gate employs a 3-wire RS485 serial port for communication between Master & Slave operators.

1. An electrical conduit for the interconnecting wires must span between the two operators.
2. Complete the installation of both of the HRG 220 operators as separate machines and verify that their basic functions are correct as solo operators before interconnecting them.
3. The two gate operators should be supplied by home runs from separate 20 Ampere circuit breakers in the main panel, but if there is only one circuit, be absolutely certain that the breaker and wire size is sufficient for the load of two motors. See Appendix 9.
4. External control inputs, vehicle detectors and entrapment protection sensors may be connected to either gate operator without regard to preference.
5. To interconnect the two operators, route a shielded twisted pair with an internal ground wire between the electric control boxes and connect to the RS485 Dual Gate terminals, in matching order on both machines: In the RS 485 shaded area connect the terminals for Master Com to Slave Com with the ground shield trace wire, and connect the Master A to Slave A and the Master B to Slave B using the insulated twisted pair of wires.
6. The Installer Menu in each machine must be set as a Master or a Slave under menu item [dg\_\_]. Set one operator as a Slave [dg\_1] and the other as a Master [dg\_2]. If the function of any external input is to be different than the factory default, configure for the desired function on the operator where that input is connected. Internal functions, such as the close timer or reversal distance, are controlled by the Master operator regardless of the settings in the Slave.
7. Once set as a Master or a Slave the operators will be in constant communication with each other. If that communication stops because the wires become severed or one operator is turned off, both machines will cease functioning and the LCD will display Err4, which is a Master/Slave communication error. This error cannot be reset until both machines are functional and communicating properly again.

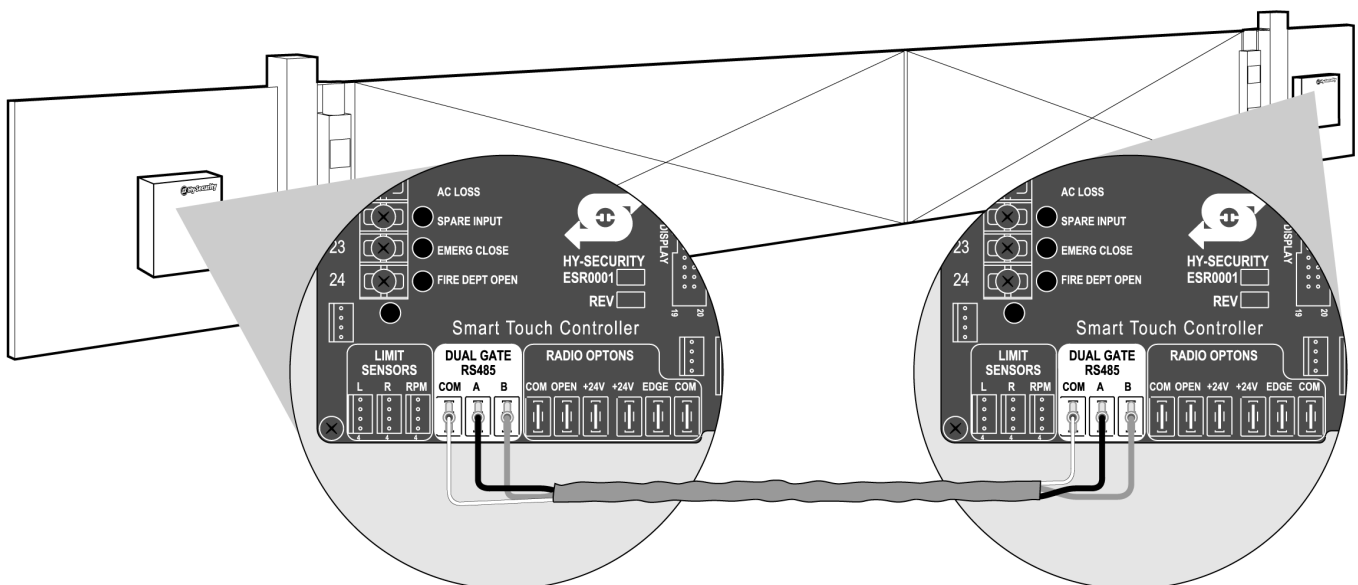

## Smart Touch Controller Menu for Hydraulic Swing Gates

**Initial Power Up** – When power is turned on, the display will disclose the software revision:

Display Revision Number	2s delay	Displays software version Number, ex. [h3.02]
-------------------------	----------	---

### System Data and accessing the User Menu Settings:

If the gate is stopped in normal mode, pressing of the **Menu button** accesses the User Menu. After the menu button is pressed, the LCD will scroll the system data in the table below. The scrolling display stops at the close timer setting, which is the beginning of the User Menu. To exit the Menu Mode, the display must not be blinking, then simply pressing the Menu button will return the display to the Run Mode and re-enable the controls. The menu mode will also automatically return to the Run Mode if there is no activity for two minutes.

	Data Displayed in Scroll	Time	Description
S1	[SLAu] or [LEAd]	2s	SLAVE Operator or LEAd Operator (master)
S2	[ot 2] Gate type (1-5)	2s	Operator type: 1=HSG, 2=HRG, 3=HVG, 4=HTG
S3	[uC _] UL usage class (1-4)	2s	Installer setting of usage class: type 1-4
S4	[d _] 24VDC Buss Voltage	2s	Actual VDC buss voltage
S5	[CC _] Life cycle counter	2s	High digits of 6 digit life cycle counter
S6	[ _] Life cycle counter	2s	Last 4 digits of 6 digit life cycle counter

Read through the options available in the User Menu and the Installer Menu on the next page and you can see that the functions of this gate operator can be configured to suit most any specific need. Once you have learned to navigate the menus, as described in #2 on page 20, and how to change a menu setting, the full range of features and choices of the Smart Touch Controller are available to use. The User Menu contains the basic configuration items and the Installer Menu contains the more advanced menu items.

	User Menu Options	Default	Description
U1	[Ct 0] Close timer setting	0	0 = Close timer off or 1 – 99 seconds
U2	[hC 0] Momentary Close	0	0 = momentary, 1= Constant hold PB required
U3	[ho 0] Momentary Open	0	0 = momentary, 1= Constant hold PB required
U4	[AP 0] AC Power loss function	0	0 – 3 (0 =Type A, 1 = B, 2 = C, 3 = D) See page 55
U5	[ro 0] Radio control option	0	0 = Open only, 1 = Adds close ability when full open
U6	[bF 2] Warn before operate	2	0 =off, 1 = Buzzer alerts 3 seconds before + in motion, 2 = Buzzer alerts 3 sec before + 2 seconds in motion
U7	[FA 0] Forced open Alert and automatic gate reposition	0	0 = off, 1 sound buzzer (2 pulses/sec) if forced open for more than four seconds, time out in 30 Sec
U8	[dA 0] Drift Closed Alert and automatic gate reposition	0	0 = off, 1 sound buzzer (2 pulses/sec) if drift closed and cannot reopen within four seconds.
U9	[PE 0] Photo Eye Align Mode	0	0= off, 1 = on (auto off when close limit triggered)
U10	[CL 0] Clock set (24 hour type)	0	0= display, 1= set mins, 2= set hours, 3= day, 4= month
U11	[Ld 5] LCD Contrast set	5	1 - 9 = Adjusts contrast of the display

### These Notes Refer to the Menu Above:

- S1 Appears only if the operator is configured as a master or a slave unit
- U1 Close timer setting does not appear when set for constant contact close to function
- U4 Power loss function only appears if factory has provided DC type operator
- U6 We strongly advise never disabling the Warn Before Operate buzzer.

## Smart Touch Controller Installer Menu Functions

The Installer Menu can be accessed only by entering the User Menu first, and then by **pressing the Reset button and the Open button** simultaneously.

To restore the factory default settings, go to menu item [Fd\_0] and change the setting to 1, then press the Program Menu button. The entire menu will reset to the factory defaults.

Installer Menu Options	Default	Description
I1 [uC 0] Set UL Usage Class	0	0 = Gate disabled, Set Class 1 through 4 use
I2 [Fd 0] Load Factory Defaults	0	0 = User settings, 1 = Load defaults (resets full menu)
I3 [dg 0] Set Master/Slave type	0	0 = Solo operator, 1 = Slave unit, 2 = Master unit
I4 [Ch 0] Set AC Charger or Solar	0	0 = DC + AC charger, 1 = DC + Solar charger
I5 [Fo 0] Enable Fire Dept. Open	0	0 = input disabled, 1 = enabled
I6 [oC 0] Enable Emergency close	0	0 = input disabled, 1 = enabled
I7 [SE 3] Inherent Sensor sens.	3	1 = Maximum sensitivity, 9 = Lowest sensitivity
I8 [SS 0] Inherent Sensor function	0	1 = stop only (note, functions in usage class 4 only)
I9 [LC 0] Leaf delay Close	0	0 = none (1-7) ½ second steps (Master/Slave only)
I10 [Lo 0] Leaf delay Open	0	0 = none (1-7) ½ second steps (Master/Slave only)
I11 [rt 0] Maximum run timer	0	0 = 60 Seconds max run, 1 = 300 Seconds max run
I12 [EC 0] PEC reverse to open	0	0 = Close eye stops only, 1 = 2 sec reverse to open
I13 [EO 0] PEO reverse to close	0	0 = Open eye stops only, 1 = 2 sec reverse to close
I14 [gr 0] Edge reverse to open	0	0 = Edge reverses fully open, 1 = Edge reverses for 2 sec
I15 [Sr 1] IES reverse to open	1	0 = IES reverses fully open, 1 = IES reverses for 2 sec
I16 [PC 0] Set PEO/ PEC – NO/NC	0	0 = Normally Open PE output, 1 = N.C. (Supervised)
I17 [gC 0] Set Edge input – NO/NC	0	0 = Normally Open Edge output, 1 = Normally Closed
I18 [tC 1] Time clock/ Interlock input	1	0 = select Time Clock, 1 = select Open Interlock
I19 [or 1] OOLD detector function	1	0 = pause closing only, 1 = enable reversing to open
I20 [ir 1] IOLD detector function	1	0 = pause closing only, 1 = enable reversing to open
I21 [hd 1] SLD Shadow detector funct	1	0 = Hold open only, 1 = Hold closed + Hold open
I22 [dL 1] Vehicle detector logic	1	1 = Std, 2 = Close timer counts down even with loops active
I23 [r1 0] User relay 1 option	1	0 = disabled, 1 – 19 = see relay output options page 31
I24 [r2 0] User relay 2 option	6	0 = disabled, 1 – 19 = see relay output options page 31
I25 [r3 0] User relay 3 option	1	0 = disabled, 1 – 19 = see relay output options page 31
I26 [tL 0] Gate Open alert	2	0 = 0 sec, 1= 15s, 2= 45s, 3= 75s, 4= 105s, 5= 135s
I27 [Lt 0] Loitering alert	3	0 = 0 sec, 1= 15s, 2= 45s, 3= 75s, 4= 105s, 5= 135s
I28 [ELd0] Test factory ELD*	0	0=Run, 1=show freq, 2=show call level 0-7, 3=set freq 1-4
I29 [iLd0] Test factory IOLD*	0	0=Run, 1=show freq, 2=show call level 0-7, 3=set freq 1-4
I30 [oLd0] Test factory OOLD*	0	0=Run, 1=show freq, 2=show call level 0-7, 3=set freq 1-4
I31 [SLd0] Test factory SLD*	0	0=Run, 1=show freq, 2=show call level 0-7, 3=set freq 1-4

\*See page 46 for description of vehicle detector & Loop Fault diagnostics

### These Notes Refer to the Menu Above:

- I1 This setting must be configured or the gate cannot function and menu will not exit.
- I4 This setting appear only if the factory has provided a DC powered gate operator
- I8 IES stop only setting [SS \_\_] does not appear unless set as a class 4 operator
- I9-10 These settings appear only if the Installer Menu is set for Master / Slave function
- I26-27 These settings appear only if the Installer Menu has set relays r1-r3 for these alerts

## Description of Functions Available in the User Menu

**User 1 [Ct \_] Close timer setting:** This menu item is the automatic close timer for the gate. The factory setting is zero, which is off. It may be configured up to 99 seconds.

**User 2 [hC 0] Momentary Close:** This menu item is to configure for the system for constant hold push button Close function. The factory setting is zero, which is momentary contact input.

**User 3 [ho 0] Momentary Open:** This menu item is to configure for the system for constant hold push button Open function. The factory setting is zero, which is momentary contact input.

**User 4 [AP 0] Power loss function:** This menu item only appears if the operator is a DC battery powered version. This item is to configure what gate function will occur when the AC power fails. See page 55 for more detailed information on DC operators.

**User 5 [ro 0] Radio control option:** This menu item is to configure whether a radio input can open only (default) or if set to 1, also has the ability to close the gate when it is fully open.

**User 6 [bF 2] Warn before operate:** This menu item controls the warn before operate buzzer and can be configured three ways. Setting the menu item to zero turns the buzzer off, but we strongly advise leaving this valuable warning feature active to alert prior to gate motion. **Never cut the wires to the buzzer or unplug it.** Set to 1 and the buzzer will sound three seconds before motion and the entire time during gate motion. Set to 2 (default) and the buzzer will sound three seconds before motion and for the first two seconds of motion.

**User 7 [FA 0] Forced open Alert and automatic gate reposition:** This function is intended for highly secure facilities. If it is enabled, by setting the selection to 1, it will reinitiate a closure if a gate is somehow forced to open far enough that the close limit switch releases. The Alert buzzer will sound immediately, even if it had been turned off, and the motor will restart to secure the gate fully closed. If the gate is not fully closed within four seconds the motor turns off and the alert buzzer sounds an intruder alert for thirty seconds. The LCD display reads ALE1.

**User 8 [dA 0] Drift Closed Alert and automatic gate reposition:** If it is enabled, by setting the selection to 1, it will restore a gate to back its fully open position if it drifts closed for any reason. The buzzer will sound a warn before operate alert, even if it had been turned off, and the motor will restart to reopen the gate. The motor will run for a maximum of four seconds and if the gate is not fully open in this period, the buzzer sounds for ten seconds and the LCD display reads ALE2.

**User 9 [PE 0] PE Alignment Mode:** This feature may be activated as an aide to photo-eye emitter / receiver alignment. The buzzer chirps once as the photo eye is triggered or twice when the photo eye is released. The Alignment Mode is cancelled with any close limit input or reset input.

**User 10 [CL 0] Clock and date set:** The Smart Touch Controller is equipped with a 24 hour 365 day clock, so that events of significance can be logged and stamped with the time and date. This feature is useful to record historical operation data, which can be accessed via the RS232 port. To set or adjust the hour, minute, day or month, see page 32.

**User 11 [Ld 5] LCD Contrast set:** Under some extreme high or low temperature conditions, it may be necessary to adjust the contrast of the LCD display. The display is adjustable from 0-9 with a factory default setting of 5.

## Description of Functions Available in the Installer Menu

- Installer 1** [uC 0] **Set UL Usage Class:** This menu item is used to set the UL usage class, which must be set by the installer before the operator will function. See page 21, step 3.
- Installer 2** [Fd 0] **Load Factory Defaults:** This menu item is used to globally restore all menu settings back to new machine status. To activate, change the setting 0 to 1 and push the Menu button. The UL usage class and the hand configuration will need to be set again.
- Installer 3** [dg 0] **Set Solo, Master or Slave type:** This menu item is used to configure an operator as a Master or a Slave operator in Master/Slave paired gate installations.
- Installer 4** [Ch 0] **Set AC Charger or Solar:** This menu item appears on 24 VDC battery machines only and is set to solar only when there is no AC battery charger.
- Installer 5** [Fo 0] **Enable Fire Dept. Open:** This menu item is used to enable the Fire Dept. Open input. When set to [Fo\_1] this input will override vehicle detectors, photo eyes and gate edges to open a gate. A reset is required before the gate can be closed.
- Installer 6** [oC 0] **Enable Emergency Close:** This menu item is used to enable the Emergency Close input. When set to [oC\_1] this input will override vehicle detectors, photo eyes and gate edges to close a gate. A reset is required before the gate can be opened.
- Installer 7** [SE 6] **Inherent Sensor sensitivity:** This menu item is to adjust the sensitivity of the internal inherent sensor. Available settings are 1-9, with 9 being the least sensitive.
- Installer 8** [SS 0] **Inherent Sensor function:** This menu item is only available in UL class 4 operators and allows an option whereby the inherent sensor will only stop the gate.
- Installer 9** [LC 0] **Leaf delay Close:** This menu item only appears if the operator is set up as a Master or a Slave. Available settings are 1-7. Each increment adds ½ second, to a maximum of 3 ½ seconds time delay, before the operator activates when commanded to close.
- Installer 10** [Lo 0] **Leaf delay Open:** This menu item only appears if the operator is set up as a Master or a Slave. Available settings are 1-7. Each increment adds ½ second, to a maximum of 3 ½ seconds time delay, before the operator activates when commanded to open.
- Installer 11** [rt 0] **Maximum run timer:** The maximum run timer has a default setting of 60 seconds. This menu item allows an optional setting of 300 seconds, if changed to [rt\_1].
- Installer 12** [EC 0] **PEC (photo eye close) reverse to open:** The default for this menu item is for non-reversal if the close photo eye is triggered. The optional setting of [EC\_1] will cause the gate to reverse to open for two seconds if triggered while closing.
- Installer 13** [EO 0] **PEO (photo eye open) reverse to close:** The default for this menu item is for non-reversal if the open photo eye is triggered. The optional setting of [EO\_1] will cause the gate to reverse to close for two seconds if triggered while opening.
- Installer 14** [gr 0] **Edge reverse to open:** The default for this menu item is for a 2 second reversal if the gate edge is triggered. The optional setting of [gr\_1] will cause the gate to reopen fully if triggered while closing.

## Description of Functions Available in the Installer Menu

**Installer 15** [Sr 1] **IES (inherent sensor) reverse to open:** The default for this menu item is for a 2 second reversal if the inherent sensor is triggered. The optional setting of [Sr\_1] will cause the gate to reopen fully if triggered while closing.

**Installer 16** [PC 0] **Set PEO/ PEC – NO/NC:** The default for this menu item is for photo eyes with Normally Open outputs. The optional setting of [PC\_1] will require a Normally Closed output. If set for N.C. the connection is also supervised and any open or short circuit fault will generate a FAL2 alert, which requires a Stop button reset to re-enable any function if triggered.

**Installer 17** [gC 0] **Set Edge input – NO/NC:** The default for this menu item is for edge sensor with Normally Open outputs. The optional setting of [gC\_1] will require a N.C. output.

**Installer 18** [tC 1] **Time clock / Interlock input:** This menu item configures the input at terminal #7 to be either for the gate interlock function, or for an external time clock to open input. The default setting is [tC\_1] for the interlock function.

**Installer 19** [or 1] **OOLD (Outside Obstruction loop detector) function:** The default for this menu item is for full reversal when the OOLD is triggered. The optional setting [or\_0] causes the gate to only pause when triggered. Closure begins as soon as the loop is clear again.

**Installer 20** [ir 1] **IOLD (Inside Obstruction loop detector) function:** The default for this menu item is for full reversal when the IOLD is triggered. The optional setting [ir\_0] causes the gate to only pause when triggered. Closure begins as soon as the loop is clear again.

**Installer 21** [hd 1] **SLD (Shadow loop detector) function:** The default for this menu item allows the shadow loop to prevent the swing gate from opening if triggered. The optional setting [hd\_0] causes the shadow loop to only prevent closure of the gate.

**Installer 22** [dL 1] **Vehicle detector logic:** This menu item is used to configure quick close logic. For swing gates, there are two modes. Mode 1 is standard logic. Mode 2 allows a faster closure by allowing the close timer to count down even when a detector loop is active.

**Installer 23, 24, 25** [r1 0], [r2 0], [r3 0] **User output relays 1 - 3 programming options:** These three menu items are used to configure the function of the three user output relays. There are 19 optional choices, which are described in detail on page 31.

**Installer 26** [t L 0] **Gate Open alert:** This menu item is to adjust the time delay before activating the user relay function #8, described on page 31. Time settings up to 135 seconds.

**Installer 27** [Lt 0] **Loitering alert:** This menu item is to adjust the time delay before activating the user relay function #13, described on page 31. Time settings up to 135 seconds.

**Installer 28** [ELd0] **Factory ELD:** Controls the HY-5A Free Exit detector, see page 46.

**Installer 29** [iLd0] **Factory IOLD:** Controls the HY-5A IOLD detector, see page 46.

**Installer 30** [oLd0] **Factory OOLD:** Controls the HY-5A OOLD detector, see page 46.

**Installer 31** [SLd0] **Factory SLD:** Controls the HY-5A Shadow detector, see page 46.

## Correctional Facility – User Optional Wiring

A special terminal strip has been pre-wired in Correctional facilities models to the three user relay outputs for easy field wiring of the common interconnect options. If alternate output functions are required, see page 30, titled Options for User Programmable Output Relays 1-3.

### Connecting an Interlocked Pair:

An interlocked pair of operators is not a Master/Slave system, but is simply two gate operators interlocked such that the one cannot open unless the other is fully closed. This connection is used frequently at correctional facilities for Sally Port gates. The Smart Touch Controller provides both an interlock input (#7) and the interlock output contact that is required.

1. User relay 1 on the Smart Touch Board has been set by the factory to provide the necessary interlock function. Connect a total of four wires between operator #1 and operator #2 as follows: One wire to the Common buss of **each** operator to the User 1 relay COM terminal of the other operator. Then, connect wires from the User 1 relay NC terminal to the Interlock input (#7) of the other operator.
2. If User relay 1 has already been used for a different function, then one of the other relays User 2 or User 3 must be wired as described above and set to output function 1. The user relays are configured in the Installer Menu as item [r1\_\_], [r2\_\_] or [r3\_\_] according to the definitions described on page 31.
3. The interlock input, terminal #7, is convertible to alternately be a time clock input, so it is possible that it may need to be switched back for the interlock function. If this alteration is needed, go to the Installer Menu, and set item [tC\_] to be [tC\_1].

### Connecting to an External Lock Mechanism:

An external solenoid lock or maglock can be controlled by the Smart Touch Controller to unlock just before gate motion begins.

1. User relay 2 has been set by the factory to provide the necessary output for a solenoid lock. Connect the voltage matching the lock solenoid to User 2 COM and connect a solenoid coil to User 2 NO (connect a maglock coil to User 2 NC). The un-switched solenoid or maglock wire connects directly to its supply voltage common conductor.
2. If User relay 2 has already been used for a different function, then one of the other relays User 1 or User 3 must be wired as described above and set to output function 6. The user relays are configured in the Installer Menu as item [r1\_\_], [r2\_\_] or [r3\_\_] according to the definitions described on page 31.

### Connecting the Gate Secure Position Indicator Output:

An external device can be signaled by the Smart Touch Controller to indicate the gate is secure.

1. User relay 3 has been set by the factory to provide the necessary output for position indication. Connect the voltage matching the indicator light to User 3 COM and connect the gate secure light to User 3 NC. The other indicator light wire connects directly to the voltage common conductor. If an unsecured light is required, connect it to User 3 NO.
2. If User relay 3 has already been used for a different function, then one of the other relays User 1 or User 2 must be wired as described above and set to output function 1. The user relays are configured in the Installer Menu as item [r1\_\_], [r2\_\_] or [r3\_\_] according to the definitions described on page 31.

## Options for User Programmable Output Relays 1-3

The Smart Touch Controller can be set to interface to many types of external devices through the use of its programmable output relays. All of the output functions listed below are accessible in the Installer Menu under the selection [r1 \_\_], [r2 \_\_] and [r3 \_\_]. Select which relay you wish to use and enter the appropriate function by the numbers as listed below.

1. **Close Limit output:** This output can also be used to create an interlock signal to another operators interlock input, or simply to indicate that the gate is secure. The relay is released at full closure.
2. **Close limit pulse output:** This output may be used in a sequenced system to command a 2<sup>nd</sup> machine to close. Generates a brief pulsed output that occurs when the close limit is triggered.
3. **Open limit output:** This output is used to indicate a full open position indication. This output becomes active when to open limit is triggered and releases when the open limit is released.
4. **Open limit pulse output:** This output may be used to trip a sequenced barrier arm gate operator to open. Generates a brief pulsed output occurs when the open limit is triggered. An additional pulse is also generated with any new open command even when the gate is already fully open.
5. **Warn before/during operate output:** This output may be used to control an external warning device. This output will operate at the same time as the internal warn before operate buzzer.
6. **Gate Lock output:** This output may be used to control external solenoid locks or magnetic locks. In both directions of travel, this output will be activated about 7/10<sup>th</sup> of a second before the operator starts moving the gate, and remains active while moving and for a few seconds after stopping.
7. **Gate forced open output:** Alarms if the gate is forced off the closed limit switch, and operator is not able to restore the gate to full closed within four seconds. This alarm resets itself in 30 seconds.
8. **Gate open too long output:** Activates when the gate has been open longer than a user-selected period of time. Adjustable from 0 delay, then 15 seconds delay to 135 seconds delay in 30-second time increments.
9. **Safety Mode Alert output:** Activated when system is in the Safety Mode or the Entrapment Mode. Safety Mode occurs upon an impact with an obstruction. Entrapment Mode means the gate is stopped and occurs if the internal inherent sensor triggers while the system is in the Safety Mode.
10. **Entrapment Mode Alert output:** Activated only when system is in the Entrapment Mode.
11. **Unauthorized Vehicle Entry output:** Activated when a 2<sup>nd</sup> vehicle enters from the outside, without a valid input from an access control device. This output releases when an access control input signals open or the gate reaches the close limit position.
12. **Outside Obstruction Vehicle Detector output:** This output may be used to interlock to an entry device to prevent pedestrian use. This output is active whenever the OOLD is tripped.
13. **Special output from "OOLD" only when gate is closed:** Used to annunciate a vehicle or to indicate loitering. Adjustable from 0 delay, then 15 to 135 seconds delay in 30-second time intervals.
14. **Gate nearing full travel output:** For operators with RPM sensors only. This output is activated when the gate is three feet from full travel in both the open and close directions. This output can be used to reduce the sensitivity of a proximity sensor near the ends of gate travel.
15. **Gate Failure output:** This output is activated to report that a problem has occurred. Indicates that system in an Error Mode, Fault Mode or Entrapment Mode. If active, the gate is disabled.
16. **Motor Running output:** This output is active when the motor is running and the gate is in motion.
17. **AC Power Failure output:** This relay is normally energized, but drops with loss of AC power. This output is also active on DC machines when the battery charger is off.
18. **DC Power Failure output:** This output is activated when the battery power is very low, but the output ceases when the battery is dead. The relay is triggered when the battery is less than 20 Volts.
19. **Flasher Relay:** This output is intended to control flashing lights that pulse once per second. The relay is activated all the time, except when the open limit switch is triggered.

## Clock Functions

### Setting the time and Date

The Smart Touch Controller is equipped with a 24 hour (military time), 365 day clock, so that events of significance can be logged and stamped with both the time and the date. This feature is useful to record key historical operational data and a log of Alerts, Faults and Errors, all of which can be accessed from the RS232 port with a PC computer or a PDA using the Palm OS. Optional Hy-Security supplied software and cables are required in order to read this data.

1. To set or adjust the time or date, go the User menu item [CL\_0] and then push the **Select button** so that [CL\_0] blinks. Press the **Next button** to change the setting from [CL\_0] to 1, 2, 3 or 4 depending upon which setting is to be altered. 1 = minutes / 2 = hours / 3 = days / 4 = months.
2. Once you have selected a blinking setting [CL 1-4], push the **Select button** (Note: you must push the Program Menu button for software versions prior to h3.01) to change the display to a blinking (adjustable) value. The following letters will be displayed on the left side to aid in knowing which setting is being made:
  - a. Setting [CL 1] = minutes – display [ni 0–59]
  - b. Setting [CL 2] = hours ---- display [hr 0–23]
  - c. Setting [CL 3] = days ----- display [dA 1-31]
  - d. Setting [CL 4] = months – display [no 1-12]
3. Make any required change to the hour, minute, day or month in the typical manner by using the **Next or Previous buttons**, then press the **Select button** to enter the change, just as typical for all of our other menu settings.
4. **When done, you may have to restore the setting to [CL 0] because the Menu button may not function to allow the user to exit the clock setting mode until the user has changed the setting back to [CL 0], which places the clock in its normal display mode.**
5. A lithium disk battery supports the clock so that the time is not lost when the main power is off. This battery should be replaced about every five years. Use a DL 2025 / DL 2032 or CR 2025 / 2032 battery.

## Entrapment Protection Device Schematic for Swing Gates

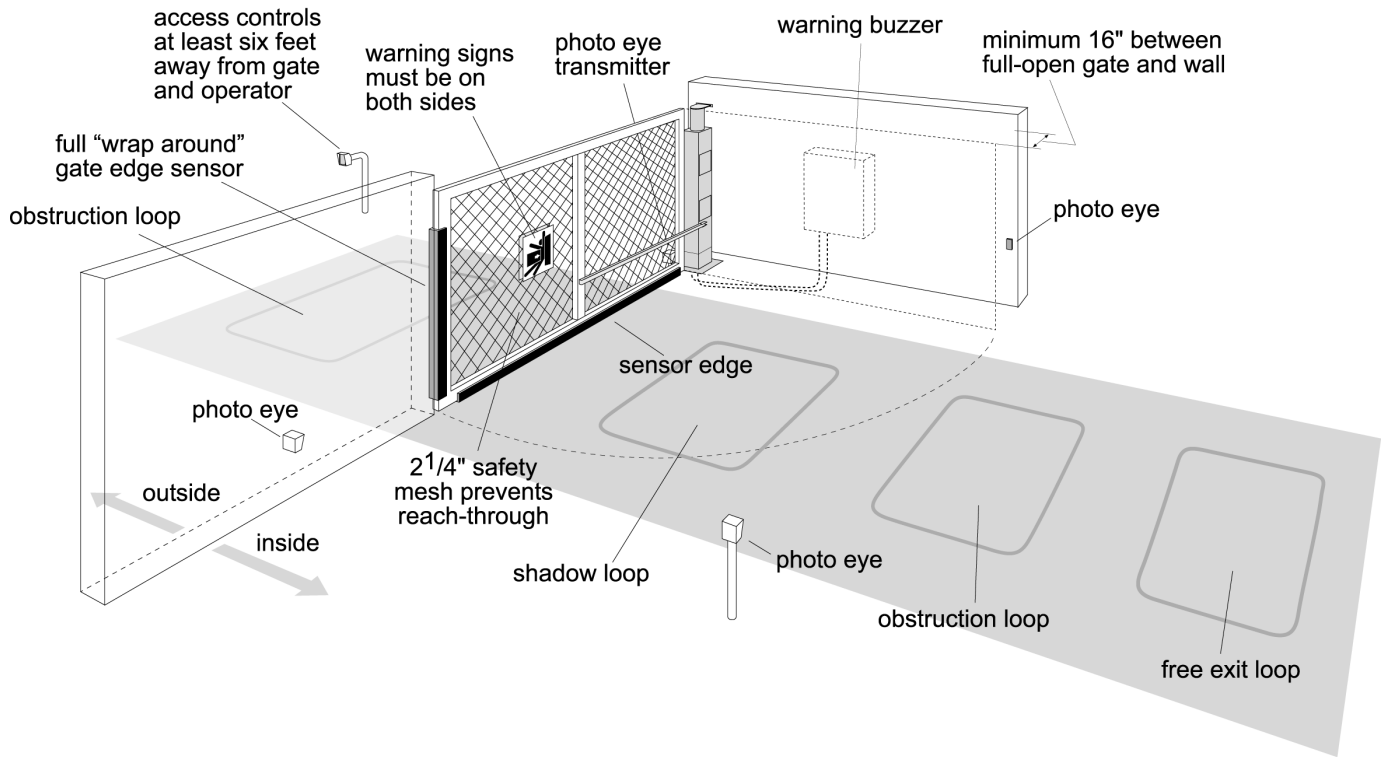

This schematic view is not meant to recommend the only way to set up your configuration, but to point out the various elements of a proper automatic vehicular gate installation. The gate operator itself is only the one component in the total system. **Always install a separate pedestrian gate.**

## UL 325 Standard requirements for Entrapment Protection Devices

### **Gate Operator Category**

#### **Horizontal Slide, Vertical Lift, Vertical Pivot, Swing and Vertical Barrier (arm)**

<b>Usage class</b>	Primary type <sup>a</sup>	Secondary type <sup>a</sup>	Primary type <sup>a</sup>	Secondary type <sup>a</sup>
Vehicular I and II	A	B1, B2, or D	A, or C	A, B1, B2, C, or D
Vehicular III	A, B1, or B2	A, B1, B2, D, or E	A, B1, or C	A, B1, B2, C, D, or E
Vehicular IV	A, B1, B2, or D	A, B1, B2, D, or E	A, B1, C, or D	A, B1, B2, C, D, or E

Note—The same type of device shall not be utilized for both the primary and the secondary entrapment protection means. Use of a single device to cover both the opening and closing directions is in accordance with the requirement; however, a single device is not required to cover both directions. A combination of one Type B1 for one direction and one Type B2 for the other direction is the equivalent of one device for the purpose of complying with the requirements of either the primary or secondary entrapment protection means.

#### **<sup>a</sup>Entrapment protection sensor types:**

Type A - Inherent entrapment sensing systems.

Type B1 - A non-contact sensor (photoelectric sensor or the equivalent).

Type B2 - A contact sensor (edge sensor device or the equivalent).

Type C - Inherent adjustable clutch or pressure relief device.

Type D - An actuating device requiring continuous pressure to maintain opening or closing motion of the gate.

Type E - An inherent audio alarm, which warns a minimum of 3 seconds before operation.

#### **UL Usage Class Information:**

The automatic vehicular operator must also be labeled as appropriate for both the type and usage class of the gate. Installers must verify that the gate operator is labeled for the intended application. Note: Sliding gate operators installed in Class I & II applications must not move the gate faster than 12 inches per second.

**Class I:** Intended for use in a home of one to four single family dwelling, or a parking area associated therewith.

**Class II:** Intended for use in a commercial location or building such as a multi-family housing unit (five or more single family units) hotel, garages, retail store or other building servicing the general public.

**Class III:** Intended for use in an industrial location or building such as a factory or loading dock or other locations not intended to service the general public.

**Class IV:** Intended for use in a guarded industrial location or building such as an airport security area or other restricted access locations not servicing the general public, in which unauthorized access is prevented via supervision by security personnel.

## Placement and Use of Secondary Pedestrian Entrapment Sensors

**WARNING: To reduce the risk of serious injury or death, read and follow all instructions in the gate operator handbook and on the warning labels.**

Automatic gate operators are intended only for vehicular use and pedestrians must be routed to a separate man gate, however sensors are still required in order to provide a degree of protection should anyone happen to stray into the area of an automatic gate. Generally there are two types of external sensors that may be used: Contact type sensors, such as an edge sensor, and non-contact sensors, such as photoelectric eyes. Current industry standards require the use of either type or both of these sensors, as a secondary device, in Class I and Class II automatic sliding gate installations, because the general public is likely to be present. Although there are alternatives for Class III and IV installations, we highly recommend the use of external sensors for all automatic gate applications.

The specifier or installer may choose either photoelectric eyes or edge sensors, or use these devices in combination, but both the open and closing directions of gate travel must be guarded. The UL 325 standard for automatic sliding gates specifically requires the following:

- One or more non-contact sensors (photoelectric eyes) shall be located where the risk of entrapment or obstruction exists, such as the perimeter reachable by a moving gate.
- One or more contact sensors (edge sensors) shall be located at the leading edge, and bottom edge of a swinging gate that has more than 6" clearance to the road.
- A hardwired contact sensor shall be located and its wiring arranged so that the communication between the sensor and the gate is not subjected to mechanical damage.
- A contact sensor that transmits its signal to the gate operator shall be located such that the signal is not impeded by building structures or other obstructions and shall function under its intended end-use conditions.
- The contact and non-contact sensors must be tested and labeled as "Recognized Components" under the UL 325 standard in order to be deemed acceptable for use in this application.

**Study the entrapment protection schematic and consider your specific installation to determine where the greatest risk of entrapment exists. Locate the edge sensors and/or the photoelectric sensors accordingly. Be certain that a sufficient number of sensors are used so that both directions of gate travel are guarded.**

## Installing Gate Reversing Edge (Contact Type) Sensor

1. Follow the guidelines in the Entrapment Protection Schematic to plan the most appropriate mounting positions for the edge sensors to be installed. For swinging gates, one or more contact sensors (edge sensors) shall be located on the inside and outside leading edge, and on the bottom edge of a swinging gate that has more than 6" clearance to the road. A requirement of the UL 325 standard is that an edge sensor be laboratory tested and "recognized" under UL 325.
2. Drill holes through the edge's mounting channel and through the surface that each gate edge is to be mounted. Securely fasten every edge sensor. Vertically mounted edge sensors should all be placed not higher than 6" above the ground.
3. Edge sensors that are not attached to the moving gate, such as post mounted sensors are wired in parallel and directly connected to the gate operator:
  - a. If the gate is swinging open to a wall with less than 16" clearance, mount a gate edge to the wall that aligns with the gate when it is in the open position.
  - b. Always route the leads of the edge sensors to the gate operator so that they are protected from physical damage.
  - c. Connect one edge sensor lead to our common buss on the power supply board and the other to terminal #13, which is labeled Edge Sensor input.
4. Edge sensors may be used with an edge transmitter and a receiver in order to transmit to the gate operator. We do not recommend the use of retractable cord reels or curl cords because of durability problems with these devices in outdoor environments.
  - a. Mount gate edge sensors to the leading edge and bottom edge of the gate so that entrapment protection is provided in both directions of travel.
  - b. Mount one or two edge transmitters (*Linear Model #3022* or equivalent) onto the gate panel near the upper corner of the leading edge of the gate. All gate edges will function correctly if only one transmitter is used, but wiring multiple edges to a single transmitter may be impractical or displeasing visually.
  - c. Connect the edge(s) to the terminals in the edge transmitter and set the DIP switches of the transmitter to match the setting in the receiver to be used.
5. Mount a commercial style radio receiver\* (external antenna type) on the inside of the operator, below the electrical box. Knock out the smallest hole in the lower right corner of the electrical box and route the wires to the area marked Radio Options. Only three wire connections are needed because the 24-Volt supply and the radio output share a wire. Being certain to observe polarity, crimp the black radio power wire together with one of the radio output wires into a .25" spade connector and connect to the COM terminal. Connect the red wire to the +24V terminal and connect the other radio output contact wire to the spade marked EDGE. Note that this terminal is the same as the #13 input terminal labeled Edge Sensor on the main control board.
  - a. Mount an external antenna onto the top of a fixed post of the fence near the operator.
  - b. Connect the antenna into the socket on the radio receiver.
  - c. Set the DIP switches in the receiver to match the same code used in the transmitter.
6. Test the operation of the reversing edge to make sure that it functions correctly. Advise the user of the gate to be certain to retest this vital function weekly.

\* If there is also to be a radio receiver for a hand held transmitter to operate the gate, be certain to use a two channel commercial receiver. Remember that the transmitter and receiver must have their codes set the same or they will not function.

## Installing Photoelectric (Non-contact) Sensors

### General Information:

Follow the guidelines in the Entrapment Protection Schematic to plan the most appropriate mounting positions for the photo-eye sensors to be installed. If there are no other secondary external entrapment protection sensors (typically an edge sensor), at least two photoelectric sensors are required to serve to reverse the gate in each direction of travel. The Smart Touch Controller has two photoelectric sensor inputs (Photo eye open and Photo eye close).

There are two common types of photoelectric sensors, thru beam and retro-reflective, each has some advantages. A thru beam sensor is generally more powerful and able to function reliably with dirty optics and in poor weather. A retro-reflective sensor has the convenience of not requiring the installation and electrical wiring of the remote emitter required in a thru beam system, but is generally more problematic in poor weather. Avoid use of a retro-reflective device to span a distance greater than 24 feet in an outdoor environment or performance will probably be unsatisfactory.

### Compatibility:

A requirement of the UL 325 standard is that a photoelectric sensor be laboratory tested and “recognized” under UL 325. In order to be compatible with a Hy-Security operator, a photo eye must be rated to function from 24 Volts DC source power.

### Installation:

Mount the photo eyes approximately 15” to 30” above the ground and as close to the gate as possible. Unless there are also gate edges for entrapment protection, a minimum of two photo eyes will be required to function for both the open and closing directions of travel. Mount the receivers on the left and right sides of the gate operator and the emitters just beyond the travel of the gate in both the full open and full closed positions of travel. In some situations, an additional photo eye should be installed on the public side of the gate. The installation locations described above are intended for pedestrian detection, if photo eyes are also to be used for vehicular detection, consider, in addition to the low elevation photo eye for cars, another photo eye at a height of about 55” to detect semi-trucks.

### Configuration:

If the photo eye has an internal switch for setting Light Operate vs. Dark Operate, select Light Operate. If the photo eye has a relay output and has both NO and NC terminals, some experimentation may be required to determine the proper connection. This is because in the Light Operate mode the output relay is normally energized and releases when the beam is blocked. Some manufacturers label an output as NO, when it is actually an NC contact. If the photo eye has a solid-state output and provides the option of a sinking or sourcing connection, choose the sinking connection.

### Connection:

Three wires to the receiver and two wires to the emitter are all that is required.

- a. The +24 Volt source power is obtained from our power supply board.
- b. The –24 Volt source power is obtained from our terminals #14 or 15, labeled (Photo Eye Power) on the Smart Touch Controller board.  
Note: The –24 Volt Photo Eye Power also supplies the photo eye Common.
- c. The photo eye NO or NC output connects to the Smart Touch Controller board at terminal #19 if the photo eye spans the road, or at terminal #17 if the photo eye spans the gate’s open position storage area.

## Installing Photoelectric (Non-contact) Sensors (continued)

### Supervised Connection:

If the photo eye being installed has a true NC output (one that is NC when the photo eye is powered, aligned and set for Light Operate) then a supervised connection is recommended. A supervised connection will signal a system Fault and prevent gate operation if either the open or close photo eye connection ever becomes an open circuit or a short circuit. The Installer Menu item [PC\_0] must be changed to [PC\_1] to enable this feature. See Installer menu 16 on page 29.

### Photo Eye Function:

A tripped photo eye will prevent the gate from starting in either direction if the gate is stationary. If tripped while in motion, the standard function is to pause the gate motion and then automatically restart again if the photo eye is clear within five seconds. An optional setting in the Installer Menu will cause a 2 second reversal of travel. See Installer menu items 12 & 13.

### Alignment:

Most photo eyes require careful optical alignment in order to aim the emitter beam to the center of the receiver or reflector. In order to avoid false triggering, it is important to carefully align the system, especially with retro-reflective photo eyes. The best way to assure true centering of the beam is with some trial testing where the emitter is shifted to move the beam left and right and up and down until the range of the invisible cone of the infrared beam is known. Photo eyes usually provide alignment aid LED's for this setup, but they can be hard to see. Hy-Security has provided a unique feature that causes our buzzer to chirp when the photo eye enters and exits alignment. See User menu 9. Set the Installer menu item [PE\_0] to [PE\_1] and the buzzer will provide an audible indication both when the beam is broken and remade.

### Notes about retro-reflective systems:

Correct installation and alignment of a retro-reflective photo eye and its reflector is important for a trouble free installation. Any system operating at a range greater than 16 feet is more prone to false triggering due to dirty optics, condensation or poor weather. If care is taken in the initial mounting and alignment of the 3-inch reflector, the chance of problems is greatly reduced.

Taking steps to protect the photo eye and the reflector from being exposed to fog and being absolutely certain the photo eye is perfectly aligned will greatly reduce any false triggering of the system. The ideal mounting of a retro-reflective photo eye is inside an enclosure of some sort.

The ideal mounting for the reflector is suspended inside a twelve-inch long piece of 3-inch PVC conduit. Cut the opening of the PVC conduit at a 45-degree angle to act as a drip shield. Hold the reflector against the backside of the PVC conduit by attaching a 3-inch male connector. Do not cement the connector, so that the reflector can be reached for future cleaning. To create a mounting base, attach a 3-inch aluminum flange (electric meter hub) to the connector. This whole package can be mounted to any flat surface.

Locate the reflector in the center of the invisible beam of infrared light to achieve the most sensitive alignment. The beam center is determined by the following test: while holding the reflector in your hand, slowly raise it until the beam is no longer returned, and the photo eye trips. Mark this maximum height. Now lower your hand and determine the lower limit of the infrared beam by watching for the trip point. Mark this position as well. Repeat the same procedure for left and right at the center elevation of the beam, as determined by the previous test. Once the four limits have been determined, either mount the reflector in the center of the area outlined or realign the eye for the position of the reflector. If the photo eye is realigned, be sure to perform the centering test again to verify that the reflector is truly in the center.

A last tip – if you coat the reflector with common dishwashing detergent, or some other anti-fogging compound, it will reduce fogging from atmospheric moisture.

## Detector Installation Guide

### Detector Basics

The vehicle detector passes a small current flow through the “loop” which then becomes an inductive coil. When a vehicle passes over a loop the detector senses the resultant drop in the inductance, and actuates the detector output.

### Loop Configurations

Configurations differ depending on the application. In parking applications with our HTG 320 operator, a loop may be as small as 3' x 6'. In traffic applications employing one of our sliding gate operators, or swing gate operators, the smallest loop should not be less than six feet square.

### Rules to Follow for Security Gate Applications

1. The side of the loop closest to the gate shall be located at least four (4) feet distant from its line of travel.
2. The shortest side of the loop shall be between six (6) and eight (8) feet in length. The longest side of the loop shall be between six (6) and twenty (20) feet in length. For applications that need to span a wide area, use several smaller loops. Do not exceed a maximum of 200 square feet of loop area to only one detector.
1. In applications with multiple loops, keep each loop at least six feet apart. This avoids “cross talk”. It is possible to have loops closer together by selecting different frequencies. An advantage of using Hy-Security model HY-5A detectors is that problematic “cross talk” is not possible.
3. For greater sensitivity and less chance of false calls caused by the motion of the gate, it is better to use two smaller loops, connected in a series circuit, to one detector instead of one large, single loop.
4. To avoid interference, keep loops at least two (2) inches above any reinforcing steel. Do not route loop wires with, or in close proximity to, any other conductors, including other loop leads, unless shielded lead-in cable is used.
5. Loop and lead-in wire should be one continuous piece. Avoid splices, if possible. If a splice is necessary for any reason, “pot” the splice in epoxy or use heat shrink to ensure that the quality of the splice covering is the same as the original wire jacket.
6. Use only 14, 16 or 18 gauge stranded wire with a direct burial jacket. Cross linked polyethylene insulation types, such as, XLPE or XHHW, will last much longer and are less prone to damage during installation than conventional insulation types. Preformed loops can be used before road surfacing or under pavers.
7. Twist loose tails of lead-in wires tightly, approximately ten times per foot.

Twist lead-in at least 10 turns per foot



Like This



Not Like This

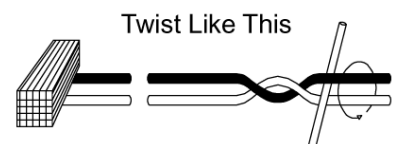

Twist Like This

E31a

## Detector Installation Guide, continued

8. Follow this guide for the correct number of wire turns according to the perimeter size of the loop:

**10 to 13 lf. = 5 turns    14 to 26 lf. = 4 turns    27 to 45 lf. = 3 turns    46 to 100 lf. = 2 turns**

9. This guide is written from a design perspective, but installation workmanship practices are equally important to insure proper operation and long loop life. The best way to insure a quality installation is to employ a professional installer experienced with detector loops. A few important practices are:
- The slot in the surface should be cut  $\frac{1}{4}$ " wide x  $1\frac{1}{2}$ " deep.
  - The corners of the cut must be at an angle or core drilled to relieve stress on the wires.
  - After the wire is installed, the slot must be completely backfilled with a non-hardening sealer. Note that if the loop wires are able to move in the slot after the sealer has set, the detector may give false calls.

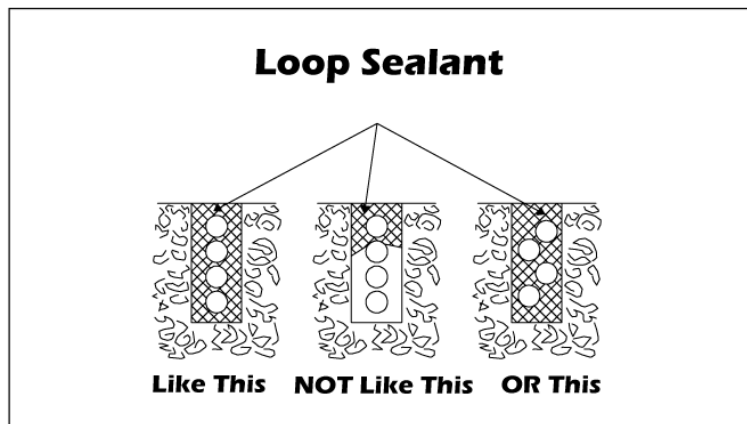

### Detector Logic

Hy-Security Gate Operators recommends that vehicle detectors be used for free open and obstruction sensing logic only. The exception is in parking applications with our HTG320 operator where detectors may be also used to close the gate. In applications employing our swing, vertical lift, or sliding gate operators, closing logic cannot be used. Because of their slower speeds, closing logic is a poor choice for security gate systems. Since there are several ways that the gate may be left standing open and because there is a loss of safety. Our circuit has not been designed to accommodate "detect to close" logic.

### Loop Diagnostics

The following tests cannot guarantee a functioning loop, but failure of either test means that the loop is definitely suspect, even though it may still be functioning at the time.

#### Test #1:

Resistance of the loop and lead-in wire should not exceed 4.0 Ohms.

#### Test #2:

The resistance to earth, as measured with a 500V "Megger", should be 100 Megohms or more. Loops may function at 10 Megohms or less but will not be reliable (e.g. when the ground is wet from rainfall). Low resistance indicates broken or moisture saturated insulation. This is common if inappropriate wire insulation has been used.

Also see section titled "Detector & Loop Fault Diagnostics" on page 46, for additional tests that may be performed with Hy-Security HY-5A mini detector modules.

FOR OPENINGS LESS THAN 30 FEET  
(See E92 for twin loop system)

BI-DIRECTIONAL TRAFFIC SYSTEM WITH CONTROLLED ACCESS ENTRY (CARD READER RADIO CONTROL, ETC.) AND FREE EXIT GATE IS CLOSED BY A "TIMER TO CLOSE". FOR A SINGLE DIRECTIONAL SYSTEM, FREE EXIT LOOP IS REPLACED BY AN OBSTRUCTION LOOP.

GATE STARTS TIMING TO CLOSE AS ALL LOOPS ARE CLEAR. TIMER IS ADJUSTABLE FROM 1 TO 30 SECONDS.

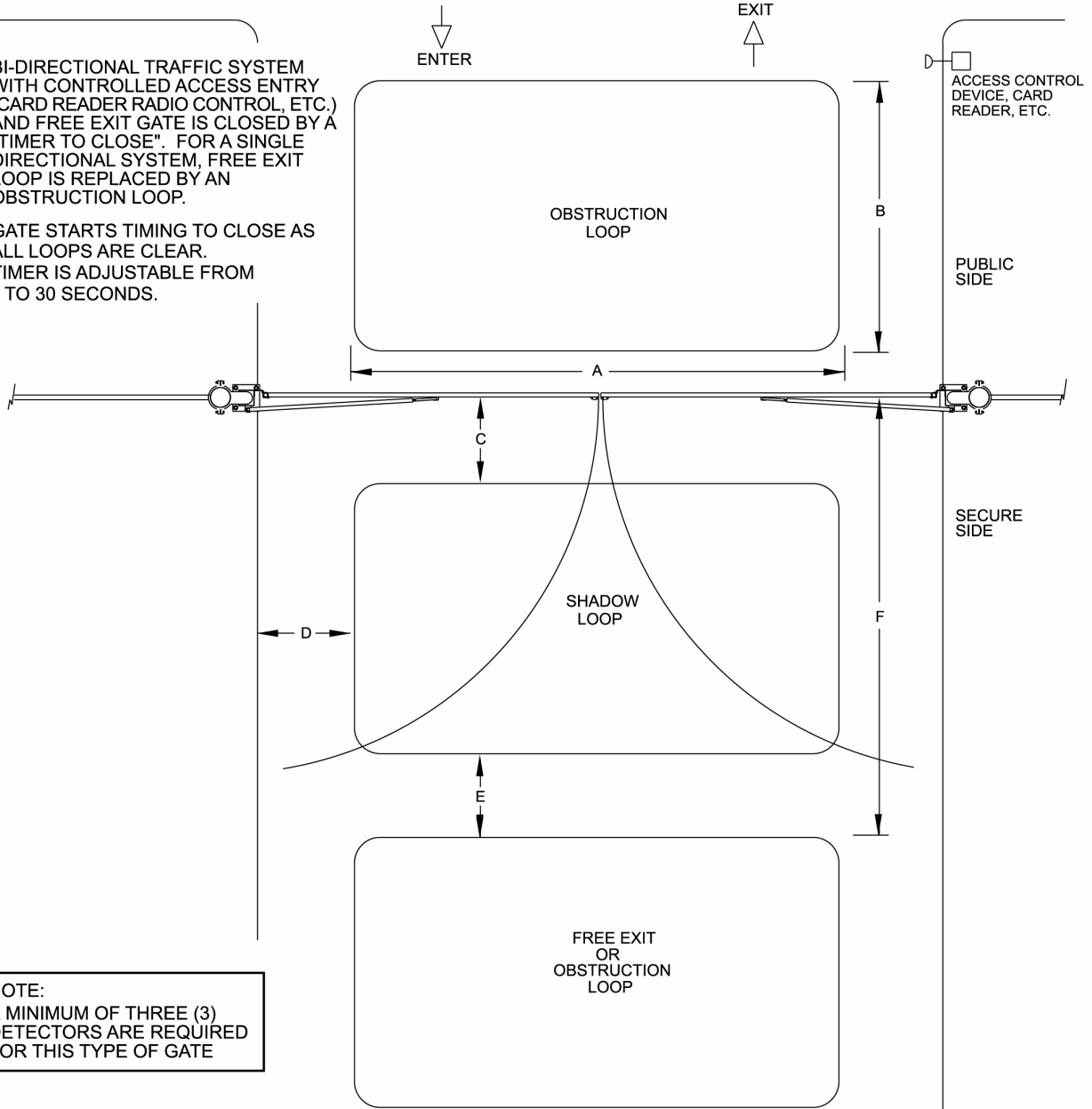

**NOTE:**  
A MINIMUM OF THREE (3) DETECTORS ARE REQUIRED FOR THIS TYPE OF GATE

- DIMENSION "A" = 6 TO 20 FEET
- DIMENSION "B" = 6 TO 8 FEET
- DIMENSION "C" = MAINTAIN 4 FEET
- DIMENSION "D" = MAINTAIN 5 FEET BETWEEN LOOP AND EDGE OF ROADWAY.  
NO VEHICLE CAN PASS THROUGH SUCH A SMALL AREA AND ESCAPE DETECTION
- DIMENSION "E" = 4 FEET MAXIMUM. VEHICLES MUST BE ABLE TO PASS FROM ONE LOOP TO THE NEXT WITHOUT LOSS OF DETECTION.
- DIMENSION "F" = DISTANCE FROM GATE TO FREE EXIT LOOP IS GATE PANEL LENGTH PLUS 4 FEET.

seattle, washington	TITLE	DRAWN	DATE	THIRD ANGLE PROJECTION		REV
	HRG220 AND HRG222 SWING GATE LOOP LAYOUT UNDER 28' WIDE	DB	05/04/00			<b>A</b>
		CHECKED	DATE	ERN NUMBER	DATE	
		APPROVED	DATE	DRAWING NUMBER		
				E91	SHT	OF
					1	1

FOR OPENINGS GREATER THAN 28 FEET  
(See E91 for single loop system)

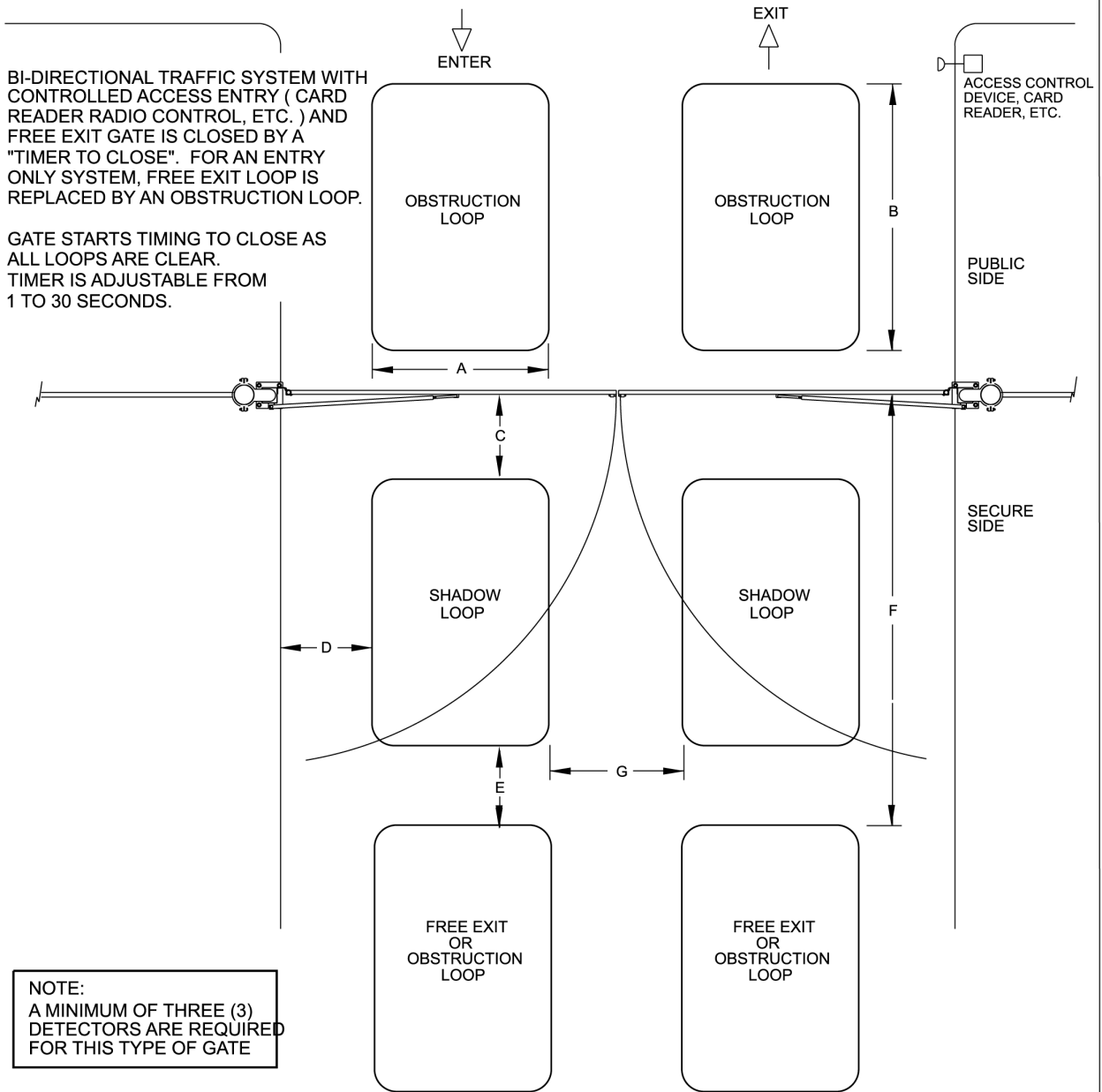

- DIMENSION "A" = 6 TO 8 FEET
- DIMENSION "B" = 6 TO 12 FEET
- DIMENSION "C" = MAINTAIN 4 FEET
- DIMENSION "D" = MAINTAIN 5 FEET BETWEEN LOOP AND EDGE OF ROADWAY.  
NO VEHICLE CAN PASS THROUGH SUCH A SMALL AREA AND ESCAPE DETECTION
- DIMENSION "E" = 4 FEET MAXIMUM. VEHICLES MUST BE ABLE TO PASS FROM ONE LOOP TO THE NEXT WITHOUT LOSS OF DETECTION.
- DIMENSION "F" = DISTANCE FROM GATE TO FREE EXIT LOOP IS GATE PANEL LENGTH PLUS 4 FEET.
- DIMENSION "G" = 4 TO 6 FEET

seattle, washington	TITLE	DRAWN DB	DATE 05/15/00	THIRD ANGLE PROJECTION		REV	
	HRG220 AND HRG222 SWING GATE LOOP LAYOUT OVER 28' WIDE	CHECKED -	DATE -	ERN NUMBER -	DATE -	<b>A</b>	
		APPROVED -	DATE -	DRAWING NUMBER E92			SHT 1 OF 1

## Vehicle Detector Installation Options

The Smart Touch Controller provides a feature rich interface to four different vehicle detector inputs. Standard box type 11 pin (24 Volt DC or 24 Volt AC) vehicle detectors may be connected in the traditional manner, see page 45. Hy-Security also offers a custom mini detector module that plugs directly into the Smart Touch Control board. Not only is the field installation much faster, but there is also a large performance benefit. The Hy-Security HY-5A detector is controlled by the Smart Touch microprocessor to achieve many benefits over common box type detectors\*

- a. Loop frequency is automatically set and monitored by the Smart Touch Controller
- b. Cross talk between multiple loops is impossible
- c. The best operating frequency for each loop is automatically chosen
- d. Smart Touch can report the both loop frequency and call strength on its LCD display
- e. Smart Touch will report loop malfunctions and store this data in its EEPROM memory
- f. Most detector or loop faults that could occur are reported and displayed on the LCD display

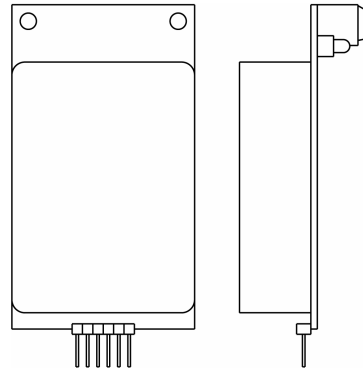

There are four vehicle detector inputs available both on the main terminal strip and as direct plug in modules. The vehicle detector inputs are for the following functions:

1. Free Exit Loop Detector – “**ELD**”
2. Outside Obstruction Loop Detector – “**OOLD**” (this is the outside reversing loop)
3. Inside Obstruction Loop Detector – “**IOLD**” (this is the inside reversing loop)
4. Shadow Loop Detector – “**SLD**” (this is for swing gates only)

\*A combination of HY-5A detectors and standard box detectors is acceptable

**It is not mandatory to use two separate detectors for inner and outer obstruction detection,** however the benefits of using this additional detector are great. Several new features are possible, such as 2<sup>nd</sup> vehicle intrusion detection, a loitering alert and selectable non-reversing. Multiple obstruction detectors may be mandatory because not more than 200 sq-ft of loop area may be connected to any one detector or the sensitivity becomes inadequate.

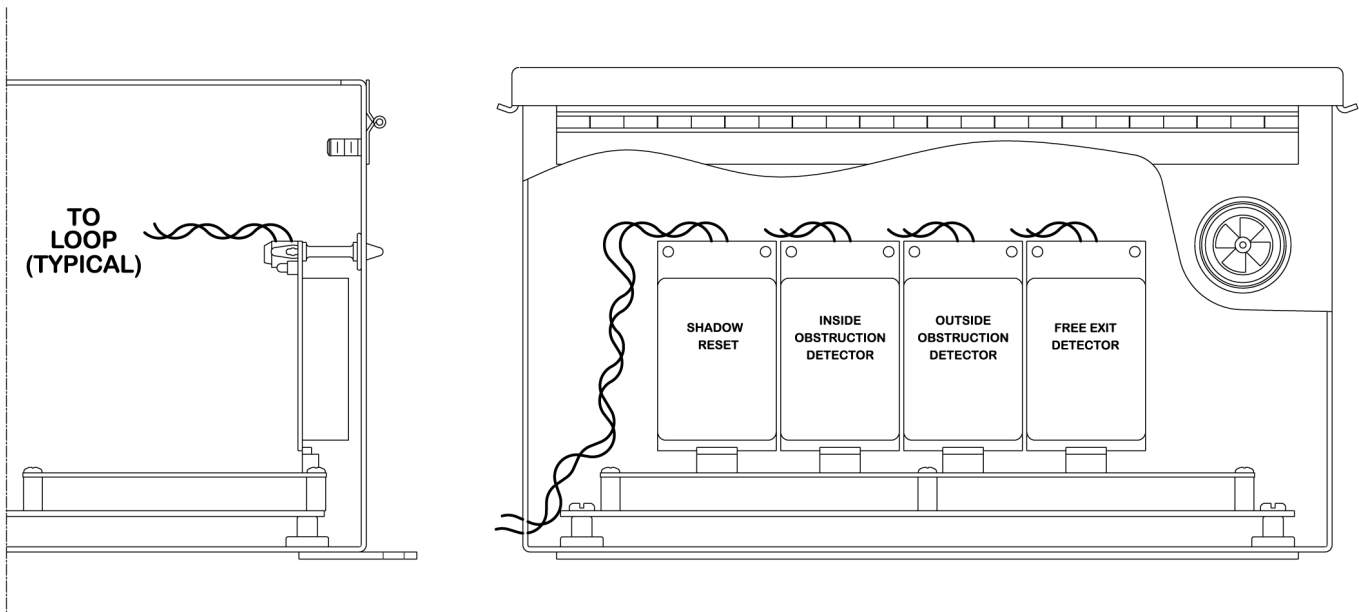

## Hy-Security Hy-5A Vehicle Detector Installation

1. Insert the locking end of each of two 1" long white plastic standoffs into the mounting holes on the detector.
2. Plug the detector into the appropriate socket along the right side edge of the Smart Touch Controller board for the detector function that is desired. Be careful to align the six detector pins into the socket correctly, and then snap the standoffs into the holes on the right side of our control enclosure.
3. Route the loop wires through the wire clips provided, and connect the loop leads to the two terminals directly on the detector. Tighten the terminal screws securely.
4. When the power is turned on, the detectors will immediately tune themselves.
5. Once enabled, if the detector module is unplugged, a communications alert [AL10] will be triggered, then if the fault continues, [Err3] "detector failed" is displayed. The operator will also run as if the affected detector is triggered. The [Err3] can only be cleared by pressing the Reset button, which electronically uninstalls the detector. See Detector & Loop Diagnostics on page 46.
6. The Smart Touch Controller automatically governs frequency selection of all Hy-5A detector modules. This simplifies installation and guarantees that there is no cross talk between multiple loops. The frequency can also be manually selected if needed, see the installer menu options.
7. Sensitivity is the only adjustment on the detector itself. Generally sensitivity does not need to be increased unless the loop is large loop or there are multiple loops connected to one detector. Do not exceed more than 200 sq/ft of loop area to one detector.

The rotary switch for sensitivity has eight settings, which are as follows:  
 0 = Low, 1 = Normal, 2 = Medium, 3 = High (0-3 with the boost feature\*)  
 4 = Low, 5 = Normal, 6 = Medium, 7 = High (4-7 no boost feature\*)

\*Boost increases the sensitivity during a call and is very useful for maintaining continuous detection when the signal may become weak, such as semi-trucks.

8. Vehicle detector functions are configurable in the Installer Menu as shown below.

Installer Menu Options		Default	Description
I19	[or 1] OOLD detector function	1	0 = pause closing only, 1 = enable reversing to open
I20	[ir 1] IOLD detector function	1	0 = pause closing only, 1 = enable reversing to open
I21	[hd 1] SLD- shadow detector function	1	0 = Hold open only, 1 = Hold closed + Hold open
I22	[dL 1] Vehicle detector logic	1	1 = std, 2 = Close timer counts even with loops active

The outside and inside Obstruction Loop Detectors "OOLD" or "IOLD" are factory configured to fully re-open the gate as a default setting. In the Installer menu, each detector can individually be set so that when the gate is closing there is only a pause if triggered. To change the IOLD setting, go to the menu item [ir\_\_] and set to 0. For the OOLD, go to the menu item [or\_\_] and set to 0.

## Standard 11 Pin Box Type Vehicle Detector Installation

1. If standard 11 pin vehicle detectors are to be used, snap up to three sockets onto the aluminum DIN mounting rail, with the key in the center hole facing to the left.
2. Both 24 Volts AC or DC are available, so either detector voltage may be used. (24 VAC is not available if the operator is a battery type) 24 VAC is available at the spade terminals on the lower left corner of our power supply (marked ACC). 24 VDC is available from the Common Buss and the +24 V spade terminals next to the common Buss.
3. Connect 24 Volt power to the detector. Polarity does not matter if the detector is a 24 AC model. If a DC detector is used, pin #1 is (+) on a DC detector and pin #2 is (-).
4. Connect the output pin #6 to the common Buss on the power supply and the output pin #5 to one of the four detector inputs (depending upon the detector function required) on the Smart Touch Controller terminal strip.
5. If multiple detectors are used, join the wires from socket to socket rather than run each to the same location separately. The only wire that must be separate is the output wire to the Smart Touch Controller as well as the loop input wires.
6. Always keep the loop wires well twisted at all places beyond the area of the loop. The lead in portion sealed in a saw cut does not need to be twisted so long as the wires are encapsulated in loop sealant and cannot move.

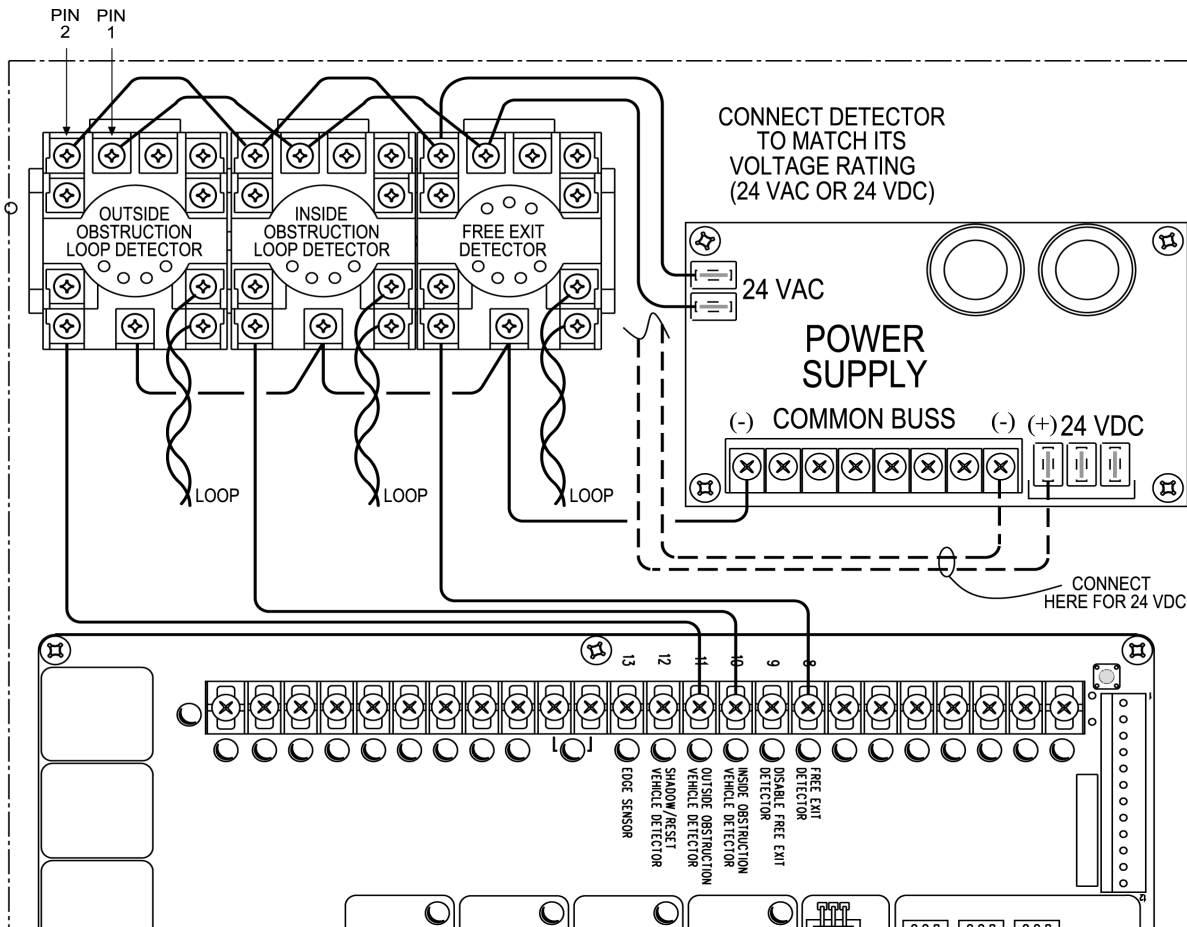

## Detector & Loop Fault Diagnostics

If Hy-Security HY-5A mini detector modules are used, the Smart Touch Controller has ability to store and report detector and loop fault information for performance diagnostics. If The Smart Touch Controller senses a loop or detector problem, the LCD display will flash the abbreviation for the affected detector (ELd – ioLd – ooLd – SLd) then it will flash the appropriate Alert Code [ALE\_] to disclose the nature of the problem and the buzzer will chirp.

Loop abnormal freq change alert	ALE7	2 chirps/sec every 15 seconds
Loop shorted to ground alert	ALE8	2 chirps/sec every 15 seconds
Loop disconnected alert	ALE9	2 chirps/sec every 15 seconds
Loop detector active >5 minutes	AL12	2 chirps/sec every 15 seconds
Loop detector comm. alert	AL10	2 chirps/sec every 15 seconds
Loop detector function alert	AL11	2 chirps/sec every 15 seconds
Loop detector failed	Err3	3 chirps/sec once per minute

Even if the loop problem self heals, historical data about detector/loop performance and a log of Alerts, Faults and Errors can be retrieved from the Smart Touch Controller by downloading from the RS232 communications port. This requires optional Hy-Security software and cables, and a PC computer or a PDA using the Palm OS, in order to read this data.

### Frequency:

Knowing the exact frequency of a loop can be useful as a diagnostic tool and verifying that the loop frequency is stable is also very valuable information. To view the actual loop frequency of a specific vehicle detector, go to the setting for that detector, then change the selection to a flashing 1 and then press the Select button. The display will flash between [F\_xx] which are the high digits, then the low digits of the loop frequency counter. For example: [F\_05] + [3413] would represent a frequency of 53,413 Hertz. The highest digit will probably be only a single digit because loop frequency is usually a five-digit number, between 20,000 to 80,000 Hertz.

### Changing the Loop Frequency:

HY-5A detectors can never cross talk, but if for any reason, you want to manually change the loop frequency, change the menu selection to a flashing 4 and then press the Select button. Each detector has a choice of four frequencies. To exit, press the Menu button and the controller will perform a reset and tune to the new frequency setting.

### Call Strength Level:

Knowing the strength level of a detector call is valuable because it provides information about how well the loop is actually “seeing” a specific vehicle. For example, it may be useful to check to see if the loop is easily detecting the middle of a high bed semi-truck. The strength of a detector call can be displayed in real time, on a scale of 1-7. As indicated in the table below, when a detector’s menu setting is set to 2, and the Select button is pressed, the LCD display will read [LE\_x]. **If the call strength is level 4 or less, consider increasing the sensitivity level**, by adjusting the rotary switch on the HY-5A detector.

	Installer Menu Options	Default	Description
I28	[ELd0] Test factory ELD	0	0=Run, 1=show freq, 2=show call level 0-7, 3= set Freq 1-4
I29	[iLd0] Test factory IOLD	0	0=Run, 1=show freq, 2=show call level 0-7, 3= set Freq 1-4
I30	[oLd0] Test factory OOLD	0	0=Run, 1=show freq, 2=show call level 0-7, 3= set Freq 1-4
I31	[SLd0] Test factory SLD	0	0=Run, 1=show freq, 2=show call level 0-7, 3= set Freq 1-4

**Acronyms:** Free Exit Loop = **ELd**, Outside Obstruction Loop = **ooLd**, Inside Obstruction Loop = **IoLd**  
Shadow Loop Detector = **SLd** (this is for swing gates only)

## 24 hr 7 day Timer Connection to Smart Touch Controller

This option generates an open command, which will hold the gate open until released.

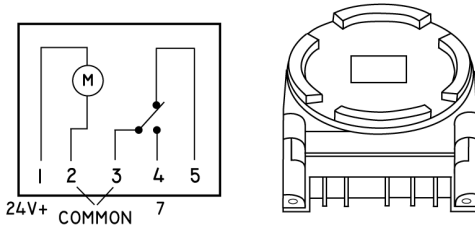

Connect Timer Power Pin 1 to 24v (+)  
 Connect Timer Power Pin 2 to common  
 Connect Timer Com Pin 3 to common  
 Connect Timer NO Pin 4 to #7, Time Clock Open

### Selecting AM/PM or Military Time

After pressing reset, the display may show AM. The numbered day symbols will be flashing on and off. If the display does not show AM, it is in military time mode. To change to AM/PM mode, press and hold the **h** key and press the **±1h** key once. AM will appear in display. If display is in AM mode and military mode is desired, press and hold the **h** key, press the **±1h** key once.

### Setting the Time

Press and hold the **⊖** key during the following:  
 (If Daylight Savings Time is in effect, press **±1h** first)

1. Press **h** to advanced to the current hour, while holding down the **⊖** key.
2. Press **m** to advance to the current minute, while holding down the **⊖** key.
3. Press **Day** repeatedly to advance to current day, while holding the down the **⊖** key.

NOTE: If the days are flashing, it indicates the day of the week was not set when setting the time. The timer cannot be programed unless the day of the week is entered. Each year, in the spring, press **±1h** to advance the time an hour. In the fall, press **±1h** to set back an hour.

### Programming 24 hour or 7 day Schedules

*It is helpful to write out the program schedules before beginning.*

#### EXAMPLE

**Program 1:** ON at 7:00AM Monday thru Saturday

**Program 3:** Off at 7:00PM Saturday

**Program 2:** OFF at 5:00PM Monday thru Friday

### Programming 24 hour or 7 day Schedules Continued...

#### These Programs need to be entered:

- |  |   |
|--|---|
| <p>Program 1: Press the <b>⏏</b> key once<br/>                 Press <b>h</b> key<br/>                 Press <b>m</b> key once<br/>                 Press <b>Day</b> key once<br/>                 Press <b>Prog.</b> key to enter</p>   | <p>ON symbol <b>⊙</b> appears<br/>                 to 07AM<br/>                 to 00<br/>                 123456 is displayed</p>        |
| <p>Program 2: Press the <b>⏏</b> key twice<br/>                 Press <b>h</b> key<br/>                 Press <b>m</b> key once<br/>                 Press <b>Day</b> key twice<br/>                 Press <b>Prog.</b> key to enter</p>   | <p>off symbol <b>⊖</b> appears<br/>                 to 05PM<br/>                 to 00<br/>                 12345 is displayed</p>        |
| <p>Program 3: Press the <b>⏏</b> key twice<br/>                 Press <b>h</b> key<br/>                 Press <b>m</b> key once<br/>                 Press <b>Day</b> key twice<br/>                 Press <b>Prog.</b> key to enter<br/>                 Press <b>⊖</b> key to enter Run Mode</p> | <p>off symbol <b>⊖</b> appears<br/>                 to 07PM<br/>                 to 00<br/>                 until only 6 is displayed</p> |

**IMPORTANT:** If an "ON" time was programed that is earlier than the current time, press **⏏** once to turn the timer "ON". (It does not "look back" to determine if it should be on or off after programing.)  
*Up to 20 Programs are able to be entered at one time.*

### Reviewing Programs

To review the programs at any time, press **Prog.** key. Programs will appear in the order they were entered with repeat presses of the **Prog.** key. After all programs have been reviewed, the blank display will appear to allow entering another program.

### Manual Override

TEMPORARY: While in the run mode, pressing, the **⏏** key once will reverse the output; ON to OFF or OFF to ON. The **⏏** symbol appears in the display to indicate a temporary override. At the next scheduled switching time, automatic control resumes eliminating the override. Continuous: While in the run mode...

\* Pressing the **⏏** key twice will turn the output to ON permanently. **⊙** symbol appears in display.

\* Pressing the **⏏** key three times will turn the output to OFF permanently. **⊖** symbol appears in display.

\* To terminate a continuous override, press the **⏏** key until **⊖** appears in the display.

## Connecting a Radio Receiver

Mount a commercial style 24 Volt radio receiver (external antenna type) on the inside of the operator, below the electrical box. Knock out the smallest hole in the lower right corner of the electrical box and route the wires to the area marked Radio Options. Only three wire connections are needed because the 24-Volt supply and the radio output share a wire. Being certain to observe polarity, crimp the black radio power wire together with one of the radio output wires into a .25" spade connector and connect to the COM terminal. Connect the red wire to the +24V terminal and connect the other radio output contact wire to the spade marked OPEN. Note that this terminal is the same as the #4 input terminal labeled Edge Sensor on the main control board.

Mount an external antenna onto the top of a fixed post of the fence near the operator.

Connect the antenna into the socket on the radio receiver.

Set the DIP switches in the receiver to match the same code used in the transmitter.

If there is also to be an edge sensor transmitter to reverse the gate, be certain to use a two channel commercial receiver. Remember that each transmitter and receiver must have their codes set the same or they will not function.

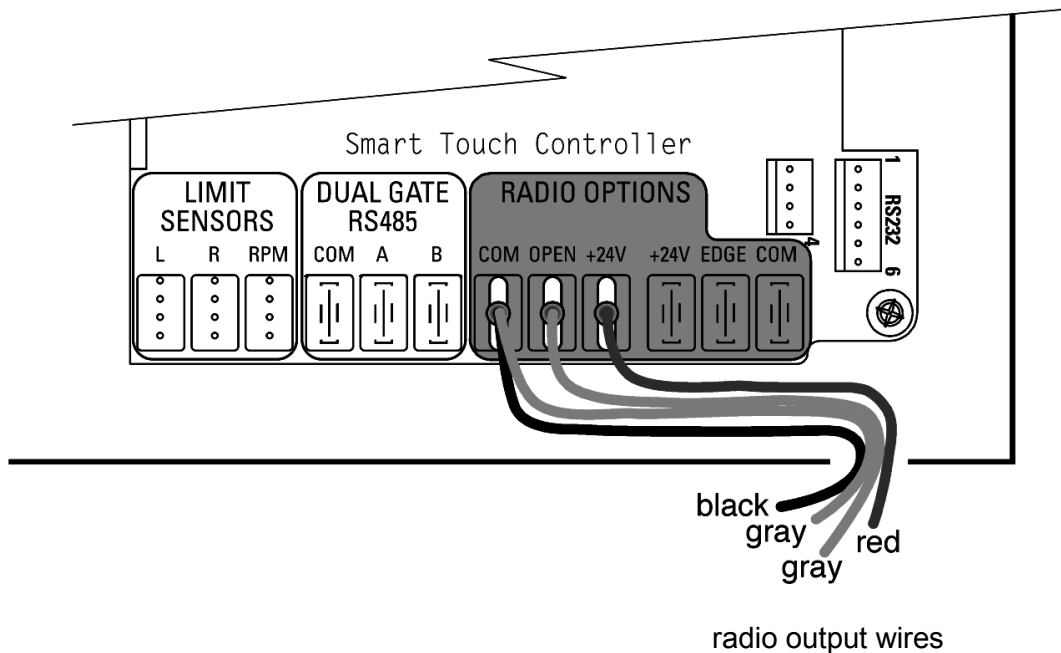

## Troubleshooting

### Trouble With Gate Movement in General:

1. Review the HRG index arm adjustment and the flow control valve adjustment on page 18.
2. Inspect the operator for hydraulic leaks both in the control panel and the base of the operator post, insure there is sufficient fluid in the reservoir, if not refill it to within 1" of the fill plug.
3. During operation listen for unusual sounds and investigate the source.

### Electrical Problems in General:

The Smart Touch Controller reports system malfunctions on its LCD display and the buzzer will emit a series of chirps at defined intervals. Review the matrix of Alerts, Faults and Errors listed on the next page. To disclose the status of all inputs on the terminal strip, the LED tact button must be pushed. This button is in the upper left corner near the Stop input.

### Specific Types of Problems:

*"I pushed the open and close buttons, but nothing runs."*

1. Verify that the line voltage is present and matches the operator voltage  $\pm 10\%$ .
2. In three phase applications insure that all three legs of line voltage pass through the power disconnect switch to the motor contactor, in case one of the lines is dropped somewhere.
3. Verify that control voltage is present at the power supply Common and 24VDC terminals. It may be necessary to reset the circuit breaker (black button) on the transformer.
4. Verify a jumper wire joins Common to Stop, if an external stop button is not used.
5. Verify there are no Faults or Errors reported on the LCD display. See table on the next page.
6. If the motor contactor chatters, voltage drop due to undersized wires is the likely cause. Check Appendix 9 for maximum allowable length of wiring runs vs. wire size.

*"The pump is running but the gate panels don't move."*

*(Hydraulic pressure is between 0 - 700 PSI on the gauge)*

1. If the power is three-phase, verify CCW motor rotation and reverse any two AC lines if needed.
2. Check the level of the hydraulic oil by removing the plug in the reservoir. If necessary, add oil at this location to within one inch of the filler hole.
3. Unplug the hoses and run the pump, look at the pressure gauge to confirm the system pressure reaches 1350 PSI. Re-attach the hoses when complete.
4. If relief pressure is not attained, remove the relief valve entirely and depress the plunger at the nose end with a blunt tool (large Allen wrench) and blow it to remove any debris. Return the valve to the power unit once cleaned.

*"Hydraulic pressure is above 700 PSI"*

1. Verify that the quick connectors at the hose ends are fully seated when connected.
2. Check the flow control valve, it must not be turned too far clock-wise. See adjustment instructions on page 17.

*"The gate panels move in the wrong direction."*

1. Check hose connections to verify the correct order red to red and brass to brass.
2. With the system engaged to open, verify that the Open Valve coil develops a strong pull. (This can be tested by removing the nut retaining the coil and grasping the coil)

*"The gate only opens or only closes."*

1. If the gate only opens, the directional valve may be stuck and need cleaning or replacement.
2. If the gate only closes, the valve coil is not being energized, or is defective.

## Troubleshooting

The Smart Touch Controller system includes many self diagnostic capabilities. The LCD will display specific messages and the Audio Alert buzzer will sound distinctive chirps. Any Alerts, Faults or Errors are also logged into a memory and stamped with a time and date. For diagnostic purposes, these messages can be retrieved with optional WinLogger™ software available from Hy-Security Gate.

**The following chart is a listing of codes that would appear on the LCD display if problems are detected by the Smart Touch Controller.**

Error, Fault, or Alert Status	LCD Display	Buzzer Chirp Sequence
Cannot respond due to tripped sensor or in Entrapment mode	Entr	2 chirps/sec every 2 seconds while control input is active
Safety Mode Alert	SAFE	2 chirps once when in Safety Mode
Low 24V Control Voltage Alert	Lo24 (ac or dc)	N/A (LCD flashes once every 5 seconds)
Critical Low 24V supply power	BadP (ac or dc)	N/A Display steady – controls disabled
Dead 24V Battery Alert –DC only	bat - dEAd	3 chirps upon any operating command
Gate forced open Alert	ALE1	2 pulses/sec for 30 seconds
Gate drift closed Alert	ALE2	2 pulses/sec for 10 seconds
Motor thermal overload Alert	ALE4	2 chirps/sec every 15 seconds
Both limits tripped Alert	ALE5	2 chirps/sec every 15 seconds
Limits not released in 10 seconds	ALE6	2 chirps/sec every 15 seconds
Loop abnormal freq change alert	ALE7	2 chirps/sec every 15 seconds
Loop shorted to ground alert	ALE8	2 chirps/sec every 15 seconds
Loop disconnected alert	ALE9	2 chirps/sec every 15 seconds
Loop detector comm. alert	AL10	2 chirps/sec every 15 seconds
Loop detector function alert	AL11	2 chirps/sec every 15 seconds
Loop detector active >5 minutes	AL12	2 chirps/sec every 15 seconds
Maximum run Fault	FAL1	1 chirp once every 15 seconds
Photo eye Fault (supervised)	FAL2	2 chirps/sec once per minute
Critical AC sag – bad supply wire	FAL3	2 chirps/sec once per minute
Directional motion Error	Err1	3 chirps/sec once per minute
Disconnected IES Error	Err2	3 chirps/sec once per minute
Loop detector failed	Err3	3 chirps/sec once per minute
Master/slave RS485 comm. Error	Err4	3 chirps/sec once per minute
EEPROM Data Error (factory)	Err7	3 chirps/sec once per minute
EEPROM Data Error (installer)	Err8	3 chirps/sec once per minute
EEPROM Data Error (user menu)	Err9	3 chirps/sec once per minute
Program Data Error	FAiL	3 chirps/sec once per minute

**The green LED near #2 on the terminal strip is the heartbeat of the processor. This LED should always blink brightly to indicate normal operation.**

**GATE SPEED:** The speed in which a hydraulic operator moves a gate is determined by the size of the pump and the size of the actuator components. Just like a gear box, this speed is not adjustable. Attempting to slow a gate by changing any valve setting will cause a great deal of inefficiency and heat. If the speed of a gate must be changed, contact your Hy-Security distributor. Extremely cold weather is unlikely to seriously affect the speed of the gate, because Hy-Security employs a special grade of hydraulic oil that we call UNIFLOW oil, which maintains a very linear viscosity over a broad range of temperatures. Because of this high quality oil and other design considerations, we rate our operators for service in ambient temperatures of –40F degrees to 130F degrees. If the speed of your operator has been affected by cold weather, verify that the gate hardware is not impaired by ice and verify that the reservoir it is filled with UNIFLOW oil. In severe conditions, consider adding a heater.

## General Maintenance

### Operator Post

The Hy-Security Swing Gate Operator is designed to require a minimum amount of maintenance.

There is no lubrication required for any part of the operator, including the cam followers located at the center of the operator. The cam followers are permanently lubricated at the factory.

Inspect the white UHMW plastic bearings at inside top & bottom of the 7" square post. If the gap between the bearing and the 5-1/2" round post exceeds 3/8", replace the bearing.

Inspect the open and close operation of the gate for speed and travel. If adjustment is necessary, refer to the information on adjustment of the flow control valve on page18.

The adjustment of the indexing arm may have to be altered to hold the gate in the correct position and allow alignment of the locking pin with its receptacle. Adjustment is usually required only after the gate has been hit by a vehicle or otherwise been damaged. To adjust, unbolt the tension where it attaches to the gate and screw the adjuster, in or out as needed. See page17 for more information.

The most reliable operation occurs when the indexing arm is adjusted to slightly "over close" the gate. The goal is to have the locking pin strike its receptacle firmly then the closing tension will aid in keeping the locking pin aligned into the receptacle.

**For assistance, contact your distributor.**

### Hydraulic System

**Fluid Level:** Under normal conditions, hydraulic systems do not consume oil. Before adding any oil, check the system thoroughly for leaks. Remove the bright metal plug in the tank, fill to plug level, then replace plug. We recommend our *Uniflow* hydraulic oil; part number **H004 1.0**, which is sold in one-gallon containers by our distributors. Automatic transmission fluid may be used, although its performance in cold weather will be sluggish unless the operator is well heated. **Never use brake fluid. It will severely damage the entire hydraulic system.**

**Look for leaks:** Occasionally there may be slight seeping at the fittings after some usage. Tightening of the fittings will usually correct the problem. If the leaking persists, replace "O" rings, fittings or hoses, if required. No further leaks should occur.

**Oil Change:** A hydraulic system does not foul its oil, unlike a gas engine, so oil changes do not need to be frequent. Oil breakdown caused by heat is the main concern. If the unit is subjected to high use, especially in a warm climate, change the oil more frequently. In general, we recommend draining the reservoir and replacing the oil at five-year intervals.

To change the hydraulic oil, remove the reservoir from the pump unit and completely, empty it. Wipe the reservoir can clean and clean any debris from the pickup screen before re-assembling. Refill with new *Uniflow* hydraulic oil (available from your distributor). To avoid overfilling, fill only through removable plug near the top of the tank. Slowly pour the oil into the tank until the oil is within one inch of the filler port. Replace the plug and wipe up any spilled oil. If any oil is allowed to remain, it will dry to a very sticky and messy consistency.

#### Cold Weather:

1. Check that your reservoir is filled with our *Uniflow* high performance oil, which is rated to -40°F.
2. Ice can partly or totally jam gate operation. In severe weather inspect the gate for excessive build-ups of snow and ice.

## General Maintenance

### Electrical Controls

***Before servicing, turn off power disconnect switch***

No routine maintenance is needed for the electrical system or controls. If the environment is very sandy or dusty, or has many insects be certain to seal all holes in the electrical enclosure. Blow the dust out of the electric panel with compressed air. A qualified technician may troubleshoot with the aid of the troubleshooting guide in this appendix. If it is necessary to call a distributor for assistance, be sure to have your model and serial number ready. Other helpful information would include the name of the job, approximate date of installation, and the service record of the operator, especially any work that has been done recently.

### Pressure Relief Valves Adjustment Procedures

To check your relief valve setting, first disconnect the hoses. Run the operator either open or closed (the gate will not move with the hose disconnected). The relief valve is found on the rear of the hydraulic power unit. It has an adjusting head and lock nut. To adjust, loosen the lock nut and screw the threaded bolt clockwise for increased pressure, counterclockwise to decrease pressure.

MODEL	FACTORY RELIEF SETTING
HRG 220	1350 PSI
HRG 222	1350 PSI

*There is only limited value in using the relief valve as an entrapment protection device. Photo Eyes or gate edges are the best methods to protect pedestrians and maintain reserve power to reliably drive the gate.*

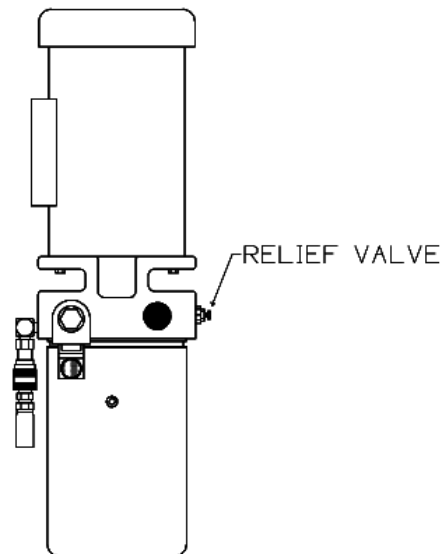

## Maintenance Schedule

### Swing Gate Operator Maintenance Schedule

Name of part	What to do		Check at these recommended monthly intervals				
			1	3	6	12	60
Gate and Hardware	Check for damage	*1	X				
Gate post	Check for excessive wear	*2			X		
Anchor bolts	Check for tightness	*3			X		
Support post	Check for movement	*4				X	
Limit Switches	Check normal function	*5				X	
Fluid level	Check for loss of fluid	*6				X	
Hydraulic fluid	Drain and replace fluid	*7					X

#### Special Notes:

\*1 Your gate will usually require more maintenance than the Hy-Security operator that is moving the gate. Damaged or warped gate panels are signs that a vehicle may have hit the gate. Verify that the actuator post is not also damaged.

\*2 Normally, with correct operator speed, the actuator post should need very little attention. If your gate panel is very heavy or in high wind area locations the six-month inspection should include a look into the post itself. Check the mounting base inspection cover you should find it clean. If there is any sign that the brass bushings have deteriorated or there is wear in the UHMW bearings at the top and bottom of the square post (a gap of more than 3/8" around the inner tube) further inspection is appropriate.

\*3 The anchor bolts at the base of the post should remain tight. If the bolts are loose, there may be an issue where the supporting post has issues or may be out of plum or the gate may have been forced.

\*4 The support post is the most critical support structure. If there is a problem with the support post, the gate panel will sag and the mounting base will be shouldering too much of the load. Correct this problem immediately.

\*5 During this inspection you will need to open the limit switch cover, and check that the limit switches are clean, tight and that the lever arms moves freely without feeling gummy. (The open limit switch is on the left, close limit on the right)

\*6 The oil level should remain approximately one inch below the filler hole. See maintenance instructions for oil filling. Loss of fluid is not normal and indicates a leak that must be located and repaired. Use "Uniflow" fluid, part **H 004 1.0**, if additional fluid is required.

## **IMPORTANT SPECIAL NOTES REGARDING D.C. POWERED GATE OPERATORS**

The on/off switch on the electric control panel of the drive unit does not disable all DC power to the operator, even if the AC power has been disabled at its source. The large rotary switch in the DC power supply enclosure must be actuated off to insure disconnect of all DC power to the drive unit.

The disconnect in the power supply must be off if the AC source power will be absent for more than one week. This avoids slowly discharging the batteries into the battery charger. Batteries will self-discharge and therefore the DC power supply must not be stored for a period longer than 6 months without recharging the batteries.

Batteries contain sulfuric acid. If batteries are dropped or damaged, be cautious not to get acid in the eyes, on skin, or on clothing.

Be certain to observe polarity when connecting the batteries, or adding accessories. Reversed polarity may result in a non-functional operator or possibly damage a component. Red is (+) positive, and black is (-) negative.

Since the electrical current under load is very high, be certain that the minimum conductor size, specified in the installation instructions, is used for the connection between the battery pack and the operator. If the battery pack is more than 20 feet from the operator, use a larger wire size, according to the distance between the operator and the batteries.

If shorted, batteries will generate a very high current. Observe special care when connecting the cables to the batteries that the polarity is correct. The batteries are connected in a series circuit: join the positive (+) terminal from one battery to the negative (-) terminal of the next battery.

Since this operator is intended to run on batteries, control of the load is important. Easier moving gates will drain less energy from the battery, preserving capacity for more cycles during a power failure.

Hy-Security uses a permanently sealed type battery, which needs no maintenance over its life span. A low voltage-sensing circuit protects the batteries from damage which could be caused by over-discharge. The charger automatically regulates its output to allow high output when the battery is partially discharged. The output will automatically be reduced to zero as the batteries become fully charged.

Batteries have a finite life. As the batteries age they will lose some of their capacity to store energy. If the total amount of back up capacity is critical, plan to replace the batteries after 5 years of use. Properly dispose of or recycle used batteries.

Batteries are rated to perform to capacity at a temperature of 77 degrees Fahrenheit. Below 77 degrees, the "amp hour" capacity is temporarily reduced. For example, at freezing, the capacity is 75%, at 10 degrees Fahrenheit, the capacity is 50%. Hy-Security insulates the battery pack to guard against this loss. Do not remove any insulation or the performance of the system may be adversely affected.

Batteries can be damaged by excessive heat, which may shorten their life span. Therefore, do not paint the battery enclosure a dark color that could cause it to absorb a lot of heat from sunlight.

## Wiring and Control Configuration for DC Operators

If this installation is a 24-Volt DC battery type gate operator, there are a few additional steps that must be completed before the system can be functional. Review the installation instructions below and the connection diagram on page 56. **Be certain the DC power disconnect switch is turned off before making any connections.**

1. Connect the heavy gage wires between the battery enclosure and the gate operator as follows: **Be certain to observe polarity carefully!**
  - a. From the battery enclosure the (+) lead connects to the lug on the large rotary power disconnect switch. The (-) lead connects to the lug on the circuit breaker. At the gate operator the (+) lead connects directly to the lug on the top of the DC electric motor. The (-) lead connects to the bottom lug on the contactor mounted alongside the DC motor. All lug connections must be tightened very securely since they pass high current to the gate operator.
2. Connect two separate 14-gage circuits between the battery enclosure and the gate operator. One circuit provides the 24 VDC to the gate operator controls and the second circuit is required so that the Smart Touch Controller knows that the battery charger is operating normally on AC power. **Be certain to observe polarity carefully!**
  - a. Connect four wires to the terminal strip in the battery supply labeled: (+)24, (-)24, COM, #21. The 24 Volt (+) and (-) terminals connect to the red (+) and black (-) wires at the on/off power switch in the gate operator.
  - b. The COM and #21 terminals connect to the Common Buss and to terminal #21 (Charger AC power loss) on the Smart Touch Controller.
3. The Smart Touch Controller User Menu (U4) provides four optional system configurations for 24-Volt DC battery type gate operators. Since this is an uninterruptible power supply system, the installer must decide, depending upon customer preference, what is to happen when the AC line power fails. There are four functional choices provided in the User Menu, item [AP\_\_].

Setting 0 (Type A): The operator functions normally until the batteries drop to 20 Volts, then auto open and lock until the battery voltage recovers to 23.5 Volts. The gate can still be manually closed only by a Close Pushbutton or an Emergency Close input and will then re-open by any open command until the battery voltage drops to 17 Volts at which time the gate is absolutely locked open.

Setting 1 (Type B): The operator functions normally until the batteries drop to 20 Volts, then auto close and lock closed until battery voltage recovers to 23.5 Volts. The gate can only be opened by a special combination of a Stop Pushbutton input, then within 1 second, an Open Pushbutton input. The Fire Department open input can open the gate without the special PBS enabling pre-input. The gate can be re-closed only by Close Pushbutton and the Emergency Close inputs. When the battery voltage drops to 17 Volts, the gate completes its final cycle and stays in the full open or full closed position, depending upon which cycle was last.

Setting 2 (Type C): The operator automatically opens five seconds after loss of AC power and locks open, until AC power is restored. The gate can still be manually closed only by a Close Pushbutton or an Emergency Close input and will then re-open by any open command until the battery voltage drops to 17 Volts at which time the gate is absolutely locked open.

Setting 3 (Type D): Same as type C, except the operator initially does nothing after loss of AC power, but then locks open after the next open command of any type.

## Battery Connection Diagram

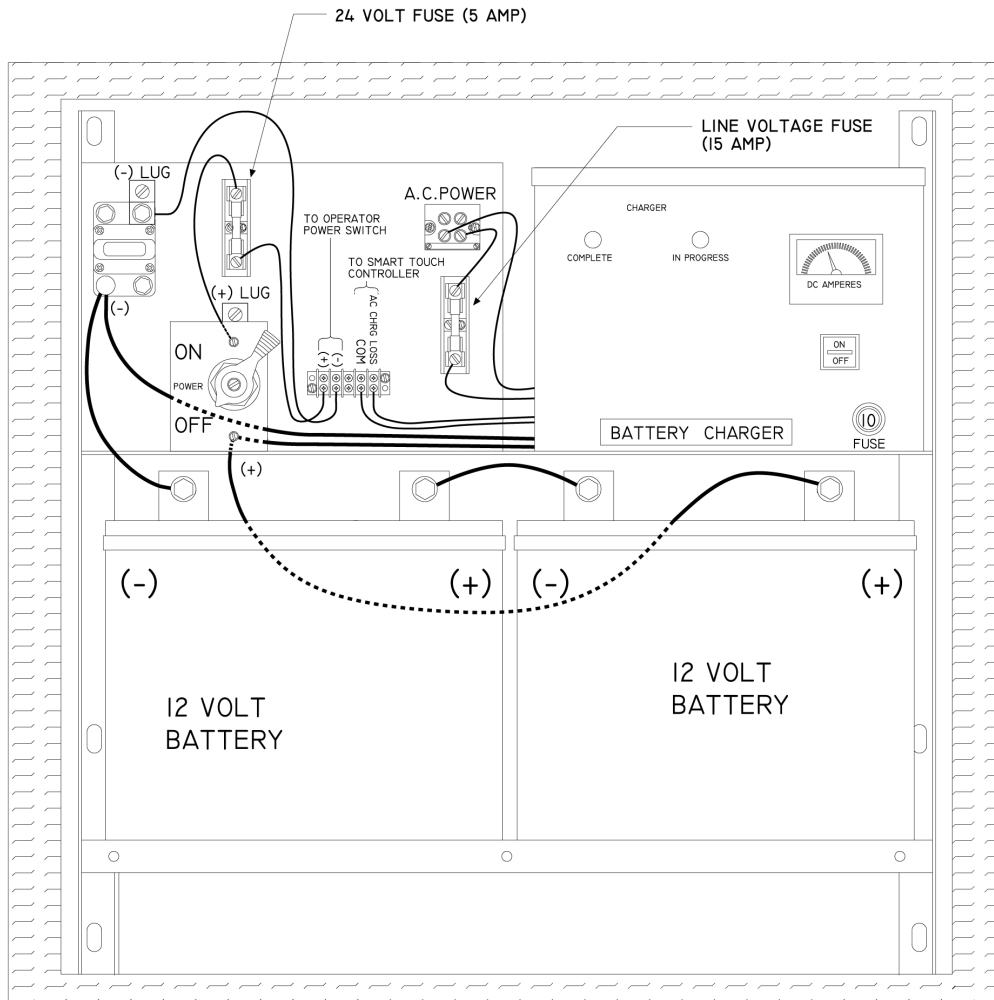

CONNECT SIX WIRES TO GATE OPERATOR AS SHOWN.

FOUR 14GA. WIRES TO CONTROL CIRCUIT  
 CONNECT FROM LUG  
 TERMINALS TO DC MOTOR:  
 TWO 6 GA. MINIMUM FOR HRG 220  
 OR  
 TWO 2 GA. MINIMUM FOR HRG 222

INSTALL BATTERIES AS SHOWN, OBSERVING POLARITY.

ALWAYS OBSERVE POLARITY CAREFULLY.  
 ALWAYS CONNECT RED WIRES TO (+) AND BLACK  
 WIRES TO (-) EXCEPT FOR WIRES CONNECTING THE  
 BATTERIES.

24V-100 A.H. BATTERY POWER SUPPLY FOR DC OPERATORS

# Battery Connection Diagram

CONNECT SIX WIRES TO GATE OPERATOR AS SHOWN.

FOUR 14GA. WIRES TO CONTROL CIRCUIT

CONNECT FROM LUG TERMINALS TO DC MOTOR:  
TWO 6 GA. MINIMUM FOR HRG 220  
OR  
TWO 2 GA. MINIMUM FOR HRG 222

INSTALL BATTERIES AS SHOWN, OBSERVING POLARITY.

ALWAYS OBSERVE POLARITY CAREFULLY. ALWAYS CONNECT RED WIRES TO (+) AND BLACK WIRES TO (-) EXCEPT FOR WIRES CONNECTING THE BATTERIES.

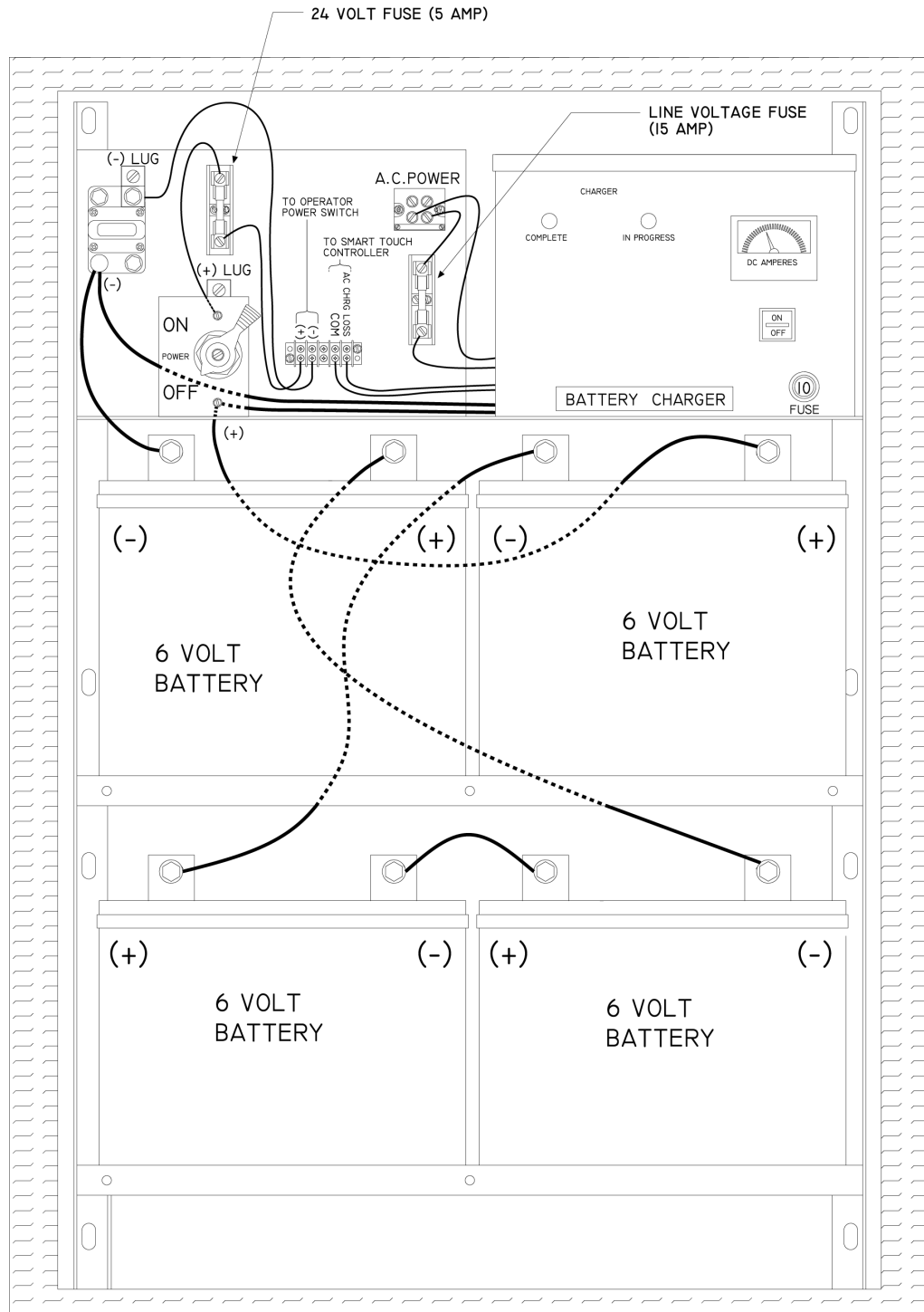

24V-170 A.H. BATTERY POWER SUPPLY FOR DC OPERATORS

## Wire Size Schedules

### For 1/2-hp through 5-hp motors

Supplying a gate operator with the right electrical service is crucial to the way the performance of the operator the life of its electrical components. If the wire size used is too small, the voltage loss—especially during motor starting—will prevent the motor from attaining its rated horsepower. The percent of horsepower lost is far greater than the percentage of the voltage loss. A voltage loss could also cause the control components to chatter while the motor is starting, substantially reducing their life due to the resultant arcing. There is no way to restore the lost performance resulting from undersized wires, except to replace them; therefore it is much more economical to choose a sufficient wire size at the initial installation.

The tables on the following page are based on copper wire and allow for a 5% voltage drop. The ampere values shown are the service factor ampere rating (maximum full load at continuous duty) of the motor.

Always connect in accordance with the National Electrical Code, article 430, and other local codes that may apply.

The maximum distance shown is from the gate operator to the power source; assuming that source power is from a panel box with adequate capacity to support the addition of this motor load. The values are for one operator, with no other loads applied to the branch circuit. Avoid placing more than one gate operator to a circuit, but if you must be certain to reduce the maximum allowed distance by half.

# Wire Size Schedules

## Wire Size for Voltage Drop Over Distance

**Wire Sizes for Power Wiring, Single Phase**    Distances are shown in the unshaded boxes

		115 V, SINGLE PHASE						208 V, SINGLE PHASE						230 V, SINGLE PHASE					
Amps	Horse Power	10.0	11.06	14.4	27.2	NA	NA	5.5	6.1	7.6	14.2	16.2	NA	5.0	5.8	7.2	13.6	14.8	27.0
		1/2hp	3/4hp	1hp	2hp	3hp	5hp	1/2hp	3/4hp	1hp	2hp	3hp	5hp	1/2hp	3/4hp	1hp	2hp	3hp	5hp
12ga		90	75	60	30			290	260	205	110	100		350	300	245	130	120	65
10ga		140	120	100	50			460	415	330	175	155		560	480	385	205	190	105
8ga		220	190	155	80			725	650	525	280	245		880	760	610	325	300	165
6ga		350	300	245	130			1,150	1,040	835	445	390		1,400	1,120	975	515	475	260
4ga		555	480	385	205			1,825	1,645	1,320	710	620		2,220	1,915	1,550	815	750	410
2ga		890	765	620	330			2,920	2,630	2,110	1,130	1,000		3,550	3,060	2,465	1,305	1,200	660

Wire Gauge

**Wire sizes for Power Wiring, Three Phase**    Distances are shown in the unshaded boxes

		208 V, THREE PHASE						230 V, THREE PHASE						460 V, THREE PHASE					
Amps	Horse Power	2.7	3.1	4.2	6.5	6.7	16	2.4	3.0	3.8	6.2	6.4	15.4	1.2	1.5	1.9	3.1	3.2	7.7
		1/2hp	3/4hp	1hp	2hp	3hp	5hp	1/2hp	3/4hp	1hp	2hp	3hp	5hp	1/2hp	3/4hp	1hp	2hp	3hp	5hp
12ga		590	510	375	245	235	100	730	585	460	280	270	115	2,915	2,350	1,850	1,130	1,100	455
10ga		930	810	600	390	375	160	1,160	930	730	450	435	180	4,640	3,710	2,930	1,800	1,740	725
8ga		1,475	1,285	950	615	595	250	1,835	1,470	1,160	710	690	285	7,340	5,870	4,650	2,840	2,750	1,150
6ga		2,350	2,045	1,510	975	945	400	2,925	2,340	1,845	1,130	1,095	455	11,700	9,350	7,400	4,550	4,400	1,800
4ga		3,720	3,240	2,390	1,545	1,500	630	4,625	3,700	2,920	1,790	1,735	720	18,500	14,800	11,700	7,200	7,000	2,900

Wire Gauge

*Always connect in accordance with the National Electrical Code, article 430, and other local codes that may apply.*

# Parts Breakout – HRG 220 Pump Packs

## AC MOTOR

Start Switch  
(60 Hz HRG 220A,  
1 phase only)  
EMOSS 012

Capacitor  
(60 Hz, 1 phase only)  
EMOCP 645 774

## DC MOTOR

DC Motor Starter  
ESWMC 075 MERC

or

### 60Hz Electric Motor

	Single Phase	Three Phase
HRG 220A:	EMOB6 215 1.0E	EMOB6 235 1.0T
HRG 220B:	EMOB6 416 1.0S	EMOB6 436 1.0S
HRG 220C:	EMOB6 416 1.0S	EMOB6 436 1.0S

### 50Hz Electric Motor

	Single Phase	Three Phase
HRG 220A:	EMOB5 215 1.0E	EMOB5 236 1A0S
HRG 220B:	EMOB5 415 1A0S	EMOB5 434 1A0S
HRG 220C:	EMOB5 415 1A0S	EMOB5 434 1A0S

### DC Electric Motor

HRG 220A: EMOSO DC6 2.02  
HRG 220B: EMOMO 024 0.75L  
HRG 220C: EMOMO 024 0.75L

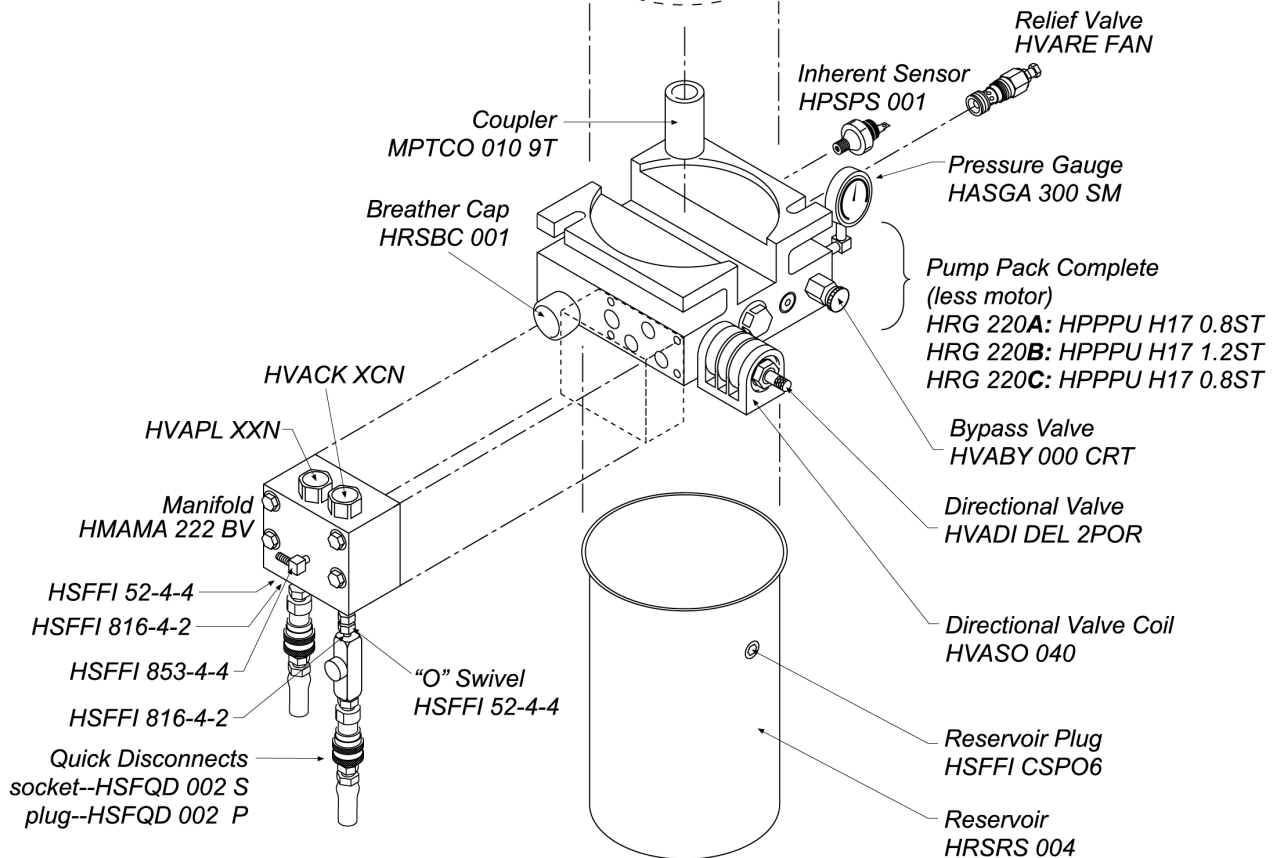

**Parts Breakout – HRG 222 Pump Packs**

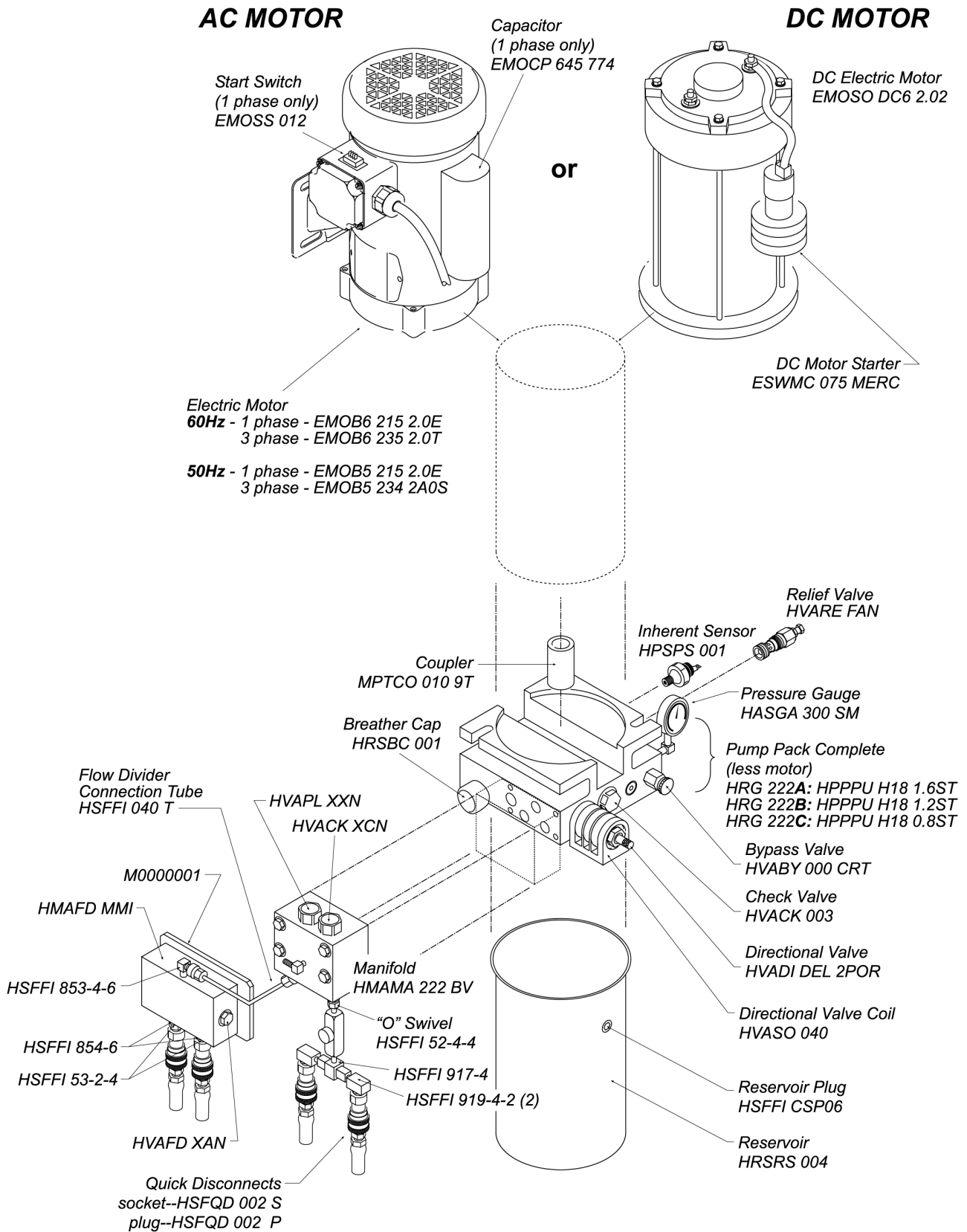

# Parts Breakout – Control Box

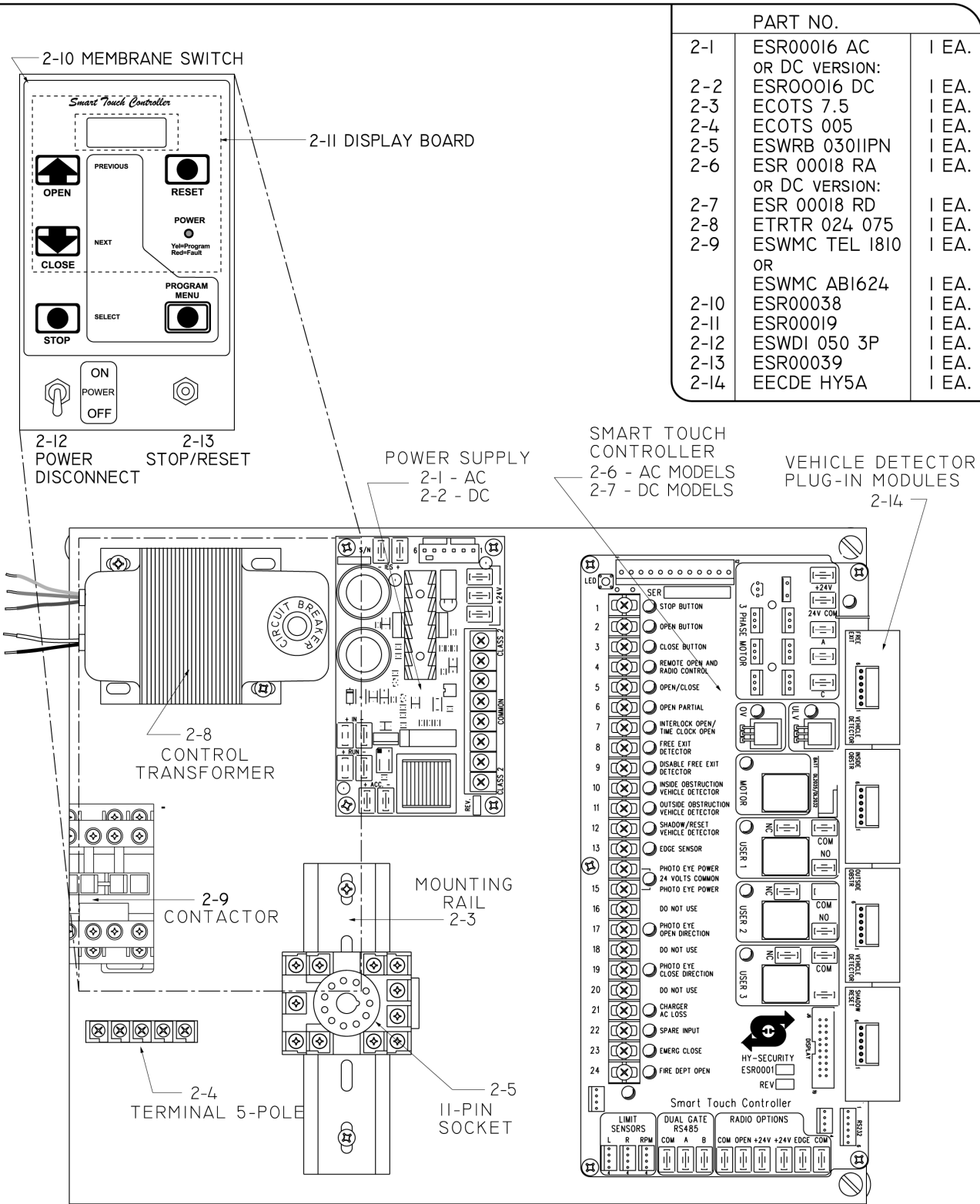

PART NO.		
2-1	ESR00016 AC OR DC VERSION:	1 EA.
2-2	ESR00016 DC	1 EA.
2-3	ECOTS 7.5	1 EA.
2-4	ECOTS 005	1 EA.
2-5	ESWRB 0301IPN	1 EA.
2-6	ESR 00018 RA OR DC VERSION:	1 EA.
2-7	ESR 00018 RD	1 EA.
2-8	ETRTR 024 075	1 EA.
2-9	ESWMC TEL 1810	1 EA.
OR		
2-10	ESWMC ABI624	1 EA.
2-11	ESR00038	1 EA.
2-12	ESR00019	1 EA.
2-12	ESWDI 050 3P	1 EA.
2-13	ESR00039	1 EA.
2-14	ECCDE HY5A	1 EA.



COMPONENT DIAGRAM - HRG CONTROL BOX

HR40



## Parts Breakout - DC Power Supply

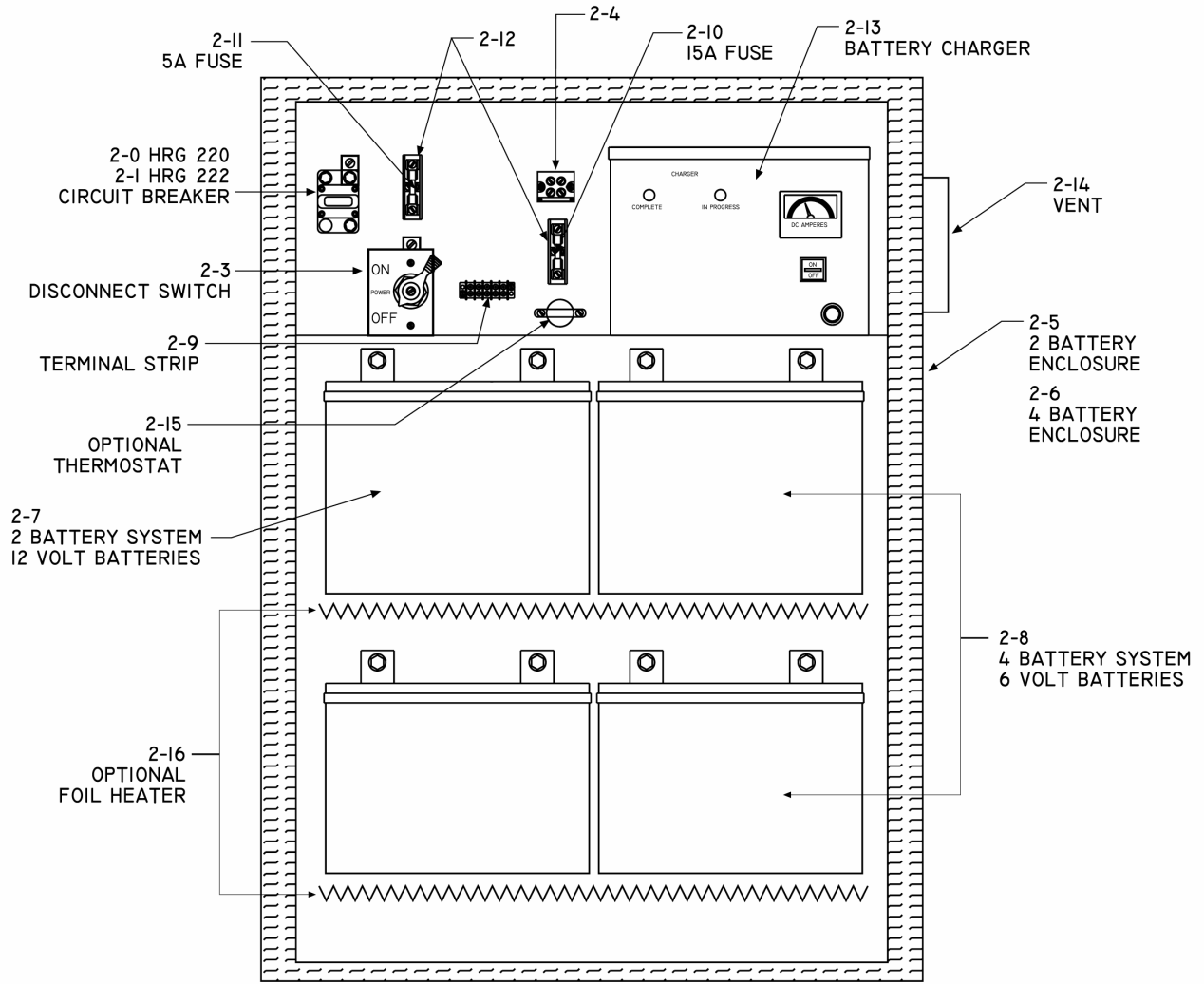

ITEM NUMBER	QTY
2-0	ESWCB 030 060   1 EA.
2-1	ESWCB 030 120   1 EA.
2-3	ESWDI 067 DCEX   1 EA.
2-4	ECOTS 1102   1 EA.
2-5	EENEN HO1 3030   1 EA.
2-6	EENEN HO1 4230   1 EA.
2-7	EDCBY 12B 090   2 EA.
2-8	EDCBY 06V 170   4 EA.
2-9	ECOTS 005   1 EA.
2-10	ESWFU 010 15   1 EA.
2-11	ESWFU 010 05   1 EA.
2-12	ESWFU 001 BLK   1 EA.
2-13	EDCBC 024 025   1 EA.
2-14	EDCFV 001   1 EA.
2-15	EACTH B10 021   1 EA.
2-16	EACHE 120 65W   2 EA.

COMPONENTS BATTERY PACK FOR DC OPERATORS

## LIMITED WARRANTY

### (Hydraulically Powered Operators)

Hy-Security Gate Operators warrants all of its manufactured products to the end-user to be free of defects in material and workmanship. **All hydraulic operators are warranted for a period of five years from date of shipment.** Slide gate operator drive wheels are warranted for a period of two years and batteries in DC operators are warranted for one year from the date of shipment. Even though included as part of a Hy-Security gate operator, accessories carrying another manufacturer's nameplate, (unless a design component of the gate operator) shall carry only the warranty of the specific manufacturer.

Any modification made to factory products will void the warranty unless the modifications are approved in writing by the factory, in advance of the change. This exclusion does not apply to normal installation of approved accessories and/or safety devices. This warranty shall not apply to equipment which has been improperly installed, subjected to negligence, accident, damage by circumstances beyond Hy-Security Gate Operators' control, or because of improper operation, maintenance, storage or to other than normal use or service.

Labor to install new parts or remove defective parts, travel time, or standby time is specifically excluded from this warranty. Freight (surface or air) and all other incidental costs are NOT covered by this warranty. There are no obligations or liabilities on the part of Hy-Security Gate Inc. for consequential damages arising out of, or in connection with, the use or performance of this product. Hy-Security Gate Inc. assumes no responsibility for other indirect damages with respect to loss of property, profit or revenue. This Limited Warranty is valid only in the 50 United States, the District of Columbia and the Commonwealth of Puerto Rico. Implied warranties, including those of merchantability and fitness for a particular purpose or application, are limited to one year from date of shipment.

Defective products that are in warranty should be returned to our factory. At our option, we may elect to repair or replace, free of charge, any such parts. An invoice will be sent at the time replacement parts are shipped, and a credit will be issued only after the parts have been returned undamaged and accepted as defective. No warranty credits will be allowed without written permission from the factory, and the return of the defective part, together with a completed Merchandise Return Form (see our Terms of Sale policy for additional details on the return procedure.) Replacement parts shall carry the remainder of the original limited warranty or 90 days, whichever is longer.

This Limited Warranty gives you specific rights. You may have others, which vary from state to state. This Hy-Security Gate Operators' limited warranty is in lieu of all other warranties expressed or implied. This Limited Warranty supersedes all other warranties.

6/01/01