

Installation Instructions

PHOTOSWITCH[®] UL325 Recognized Photoelectric Sensors

Models	Sensors	10-55V DC/20-40V AC Models	70-264V AC/DC Models
		2m 300V cable	60-2728
	5-pin mini QD	60-2729	60-2731
Optical	Sensing Mode	Retroreflective	
	Sensing Distance	2.54cm to 9.15m (1" to 30') with AB#92-39 reflector	
	Transmitting LED	Visible Red, 660nm	
	Field of View	1.5°	
	Operating Mode	Light/dark operate selectable	
	Sensitivity Adjustment	Yes	
Electrical	Operating Voltage	10-55V DC/20-40V AC	70-264V AC/DC
	Supply Current	40mA max	15mA max
	Power Consumption	2.2W / 1.6VA	
	Protection	False pulse on power-up, overvoltage, reverse polarity, outputs short circuit (SCP) protected	
	Output Type	SPDT EM Relay	
	Output Load Current/Voltage	1A @ 264V AC, 2A @ 132V AC	
	Response Time	15ms	
	Leakage Current	Not applicable	
Mechanical	Housing/Lens Material	Valox [™] /Acrylic	
	LED Indicators	See table below	
	Connection Types	SJTOW outdoor rated 2m, 300V cable, 5-pin AC mini QD	
	Supplied Accessories	AB #60-2725 impact bracket	
	Optional Accessories	#92-39 reflector, 889N-F5AF-6F cordset	
Environmental	Operating Temperature	-34°C to +70°C (-29°F to +158°F)	
	Relative Humidity	5-95%	
	Operating Environment	NEMA 3, 4, 4X, 6P, 13, IP67 (IEC529); 1200psi (8270kPa) washdown	
	Approvals	c-UL recognized (UL325), CE marked for all applicable directives	
	Protections	All versions: false pulse, reverse polarity, overload, short-circuit	
	Vibration	10-55 Hz, 1mm amplitude, meets or exceeds IEC 60947-5-2	
	Shock	30G with 1ms pulse duration, meets or exceeds IEC 60947-5-2	

Wiring Diagrams

Cable Model: 60-2728, 60-2730

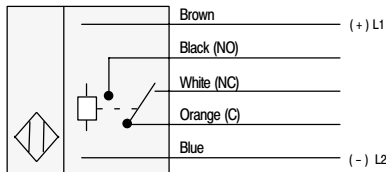

5-pin AC/DC Mini QD Model: 60-2729, 60-2731

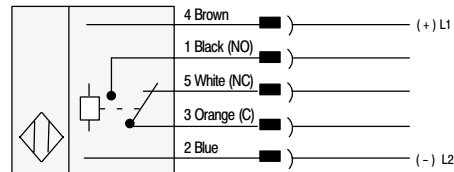

Note: Quick-disconnect wiring codes shown are valid for Allen-Bradley cables only.

User Interface

Label	Color	State	Status	Top View Detail
Output	Green	OFF	Sensor output de-activated	
		ON	Sensor output activated	
Margin/SCP	Red	OFF	Margin < 2.5	
		ON	Margin > 2.5	
		Flashing	Output SCP active	
Power	Yellow	OFF	Sensor not powered	
		ON	Sensor powered	

Dimensions—mm (inches)

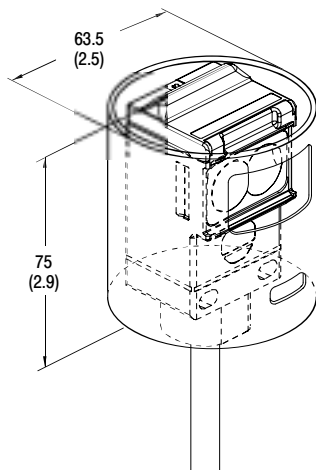

Connector Version



Typical Response Curves

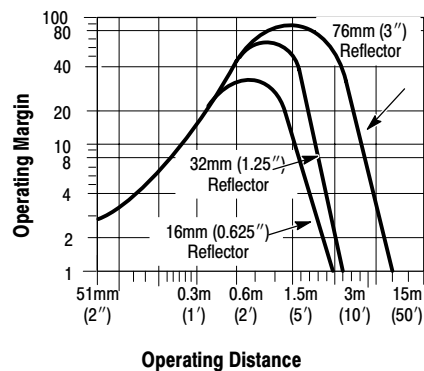

Installation

The sensor must be mounted on a firm, stable surface or support. A mounting platform which is subject to excessive vibration or shifting may cause intermittent operation. All wiring between the sensor and the automation system should conform to the National Electric Code and all applicable local codes. See wiring diagrams for proper connections.

When power is applied to the sensor, the yellow indicator will turn ON. Visually sight the sensor at the reflector until the green indicator turns ON (with sensor in light operate mode) or OFF (with sensor in dark operate mode). Continue to align the sensor vertically and horizontally until the red indicator turns ON.

Once the sensor has been properly aligned, the sensitivity can now be set. This is accomplished through the use of the sensitivity knob on the user interface panel. Open the top cover to access this knob. The default setting is in the full clockwise position which will provide maximum sensitivity and range. Turn the knob counterclockwise until the red indicator turns OFF. This indicates that the threshold where the sensor is receiving at least 2.5X the required amount of light (margin) necessary to activate the output. Turn the knob clockwise to a point where the indicator just turns ON. Normal industrial environments range from moderately dusty to extremely dirty. A higher operating margin is typically desirable to overcome the accumulation of dust/dirt on the optics lens over a period of time. Refer to the Typical Response Curve to determine the margin versus distance characteristics of the sensor. Close the top cover securely.

QD Cordsets and Accessories

Description	Catalog Number
1.8m (6ft) 5-pin, Mini QD Cordset	889N-F5AF-6F
76mm (3in) Diameter with Center Mount Hole	92-39
32mm (1.25in) Diameter	92-47